

- **Model MPK: Profile version**
- **Model MSK: Rod version**
- Measuring strokes from 25 to 7600 mm
- Contactless, robust system
- Resolution up to 1 µm
- Up to 5 positions measurable simultaneously
- Speed signal
- Transmission rate up to 100 MBit/s
- Parameterisable via the bus
- Protection types up to IP 67
- Operating temperature range -40°C ... +75°C
- Rod version pressure stability up to 350 bar

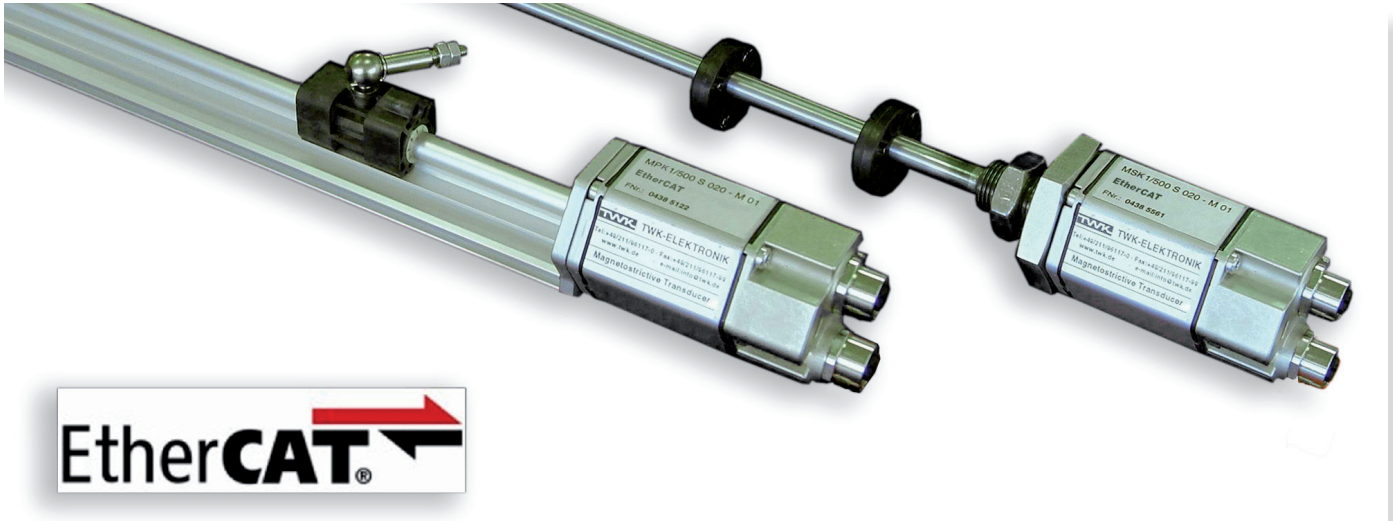

Structure and operation

The displacement transducers operate according to the principle of run time measurement between two points of a magnetostrictive waveguide. One point is determined by a moveable position ring, whose distance from the null point corresponds to the section to be measured. The run time of an emitted impulse is directly proportionate to this section. Conversion to a displacement signal takes place in the downstream electronics.

The waveguide is housed in a pressure-resistant stainless steel tube or extruded profile. To the rear of this is a die-cast aluminium housing containing the electronics in SMD technology.

In the rod version, the position magnet is located in a ring, which is guided over the rod without contact. In the profile version, it is located either in a slider, which is linked to the moving part of the machine via a ball joint, or it moves as a liftable position magnet, without wear, over the profile.

Standard measuring strokes

- Up to 1000 mm in 50 mm steps
- Up to 5000 mm in 250 mm steps (profile version: MPK)
- Up to 7600 mm in 250 mm steps (rod version: MSK)

Characteristics of the EtherCAT interface

The MXK magnetostrictive displacement transducers meet all EtherCAT requirements and can be connected directly to the field bus. Their measured data are converted to displacement-proportionate, bus-capable output signals in the sensor and are transmitted directly to the control system.

In addition to useful data transmission, software integrated into the sensor supports extensive monitoring and diagnostic functions, which can be configured via the enclosed XML file during installation. Use of the CANopen over EtherCAT message enables parameters and diagnostic data to be handled as usual in the case of CANopen. The most important key data of the displacement sensors with EtherCAT interface include:

Sensor output signals:

- 4-byte position data
- 4-byte speed data
- 2-byte status and error messages

Selectable parameters:

- Measuring direction: Forwards/backwards
- Resolution
- Extrapolation

Address setting:

Manual setting of the node address and the baud rate is omitted. The network subscribers only have to be selected and arranged according to their sequence in the EtherCAT master.

XML file:

The XML file for integrating the sensor into the EtherCAT master system and the user manual in PDF format are contained in the enclosed CD-ROM.

Diagnosis

The LEDs (green/red) in the sensor head are used for setting and additionally provide information on the sensor status.

Green	Red / Green	Meaning
Flashing	off	Normal function
Flashing	red	Magnet not in the setting range, incorrect number of magnets
Flashing	Flashing red	Undervoltage
Flashing	green	Initialisation

Block diagram

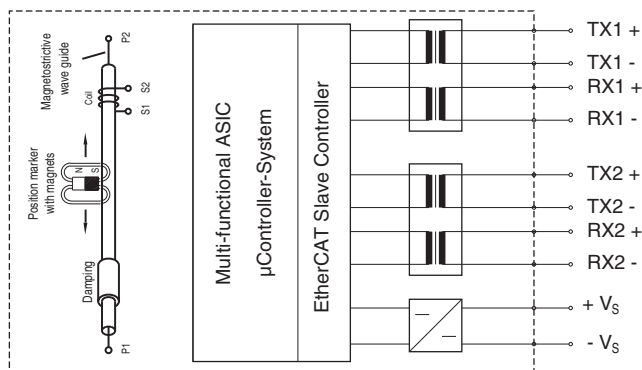

Technical data

- Operating voltage range V_s : 24VDC (+20 / -15%)
- Operating current I_s : 80 mA (typical)
- Resolution
 - Displacement in μm : 1 ... 1000 μm
 - Speed: 1 mm/s
- Linearity: $< \pm 0.01\%$ (min. $\pm 50 \mu\text{m}$)
- Repeatability: $< \pm 0.001\%$ (min. $\pm 2.5 \mu\text{m}$)
- Hysteresis: $< 4 \mu\text{m}$
- Temperature drift: $< 15 \text{ ppm} / ^\circ\text{C}$
- Measurement cycle time: Depending on meas. length
- Process data rate: Max. 10 kHz, data are extrapolated
- Operating temperature range: -40°C to $+75^\circ\text{C}$
- Dew point, humidity: 90% rel. humidity, no condensation
- Shock test: 100 g to IEC Standard 68-2-27
- Vibration test: 15 g / 10 to 2000 Hz to IEC Standard 68-2-6
- Protection type
 - Profile: IP 65
 - Rod: IP 67
- Operating pressure for rod: Max. 350 bar
- EMC test: EN 50081-1, EN 50082-2, EN 61000-4-2/3/4/6
- **Output:**
 - Interface: EtherCAT
 - Signal transmission: Fast Ethernet, 100 Base-Tx
 - Transmission rate: Max. 100 MBit/s

EtherCAT mating connector

- Connection type: M12 connector D-coded 4-pin
- Housing: Die-cast zinc, nickel-plated, straight
- Contacts: Pins, gold
- Wire connection: Cage tensioning spring
- Connection cross-sec.: Max. 0.75 mm²
- Cable diameter: 6 - 8 mm
- Protection type: IP 67

Supply mating connector

- Connection type: M8 connector, A-coded, 4-pin
- Housing: Plastic, straight
- Contacts: CuZn, CuSn
- Wire connection: Screws
- Connection cross-sec.: Max. 0.5 mm²
- Cable diameter: Max. 5 mm

Pre-assembled industrial Ethernet data cable

- Connection type: M12 connector D-coded 4-pin
- Contacts: Pins, gold
- Cable type: PUR, halogen-free, Profinet type C
- Cable cross-section: 4 x 0.38 mm² (AWG 22)
- Cable diameter: 6.2 mm
- Protection type: IP 67

Multi-magnet measurement

The MXK EtherCAT sensor enables a maximum of 5 positions and 5 speeds to be measured simultaneously with one sensor. Please note that the distance between the individual magnets must be at least 75 mm in this case.

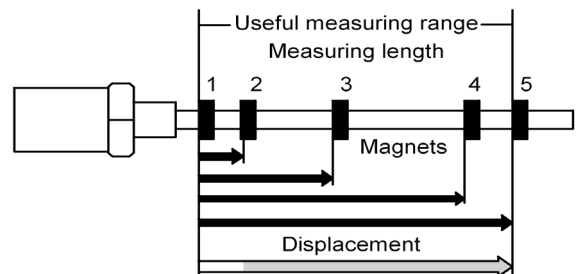

Order code formats

■ Displacement transducer

MPK 1 / 1000 S 001 - 1 M 01

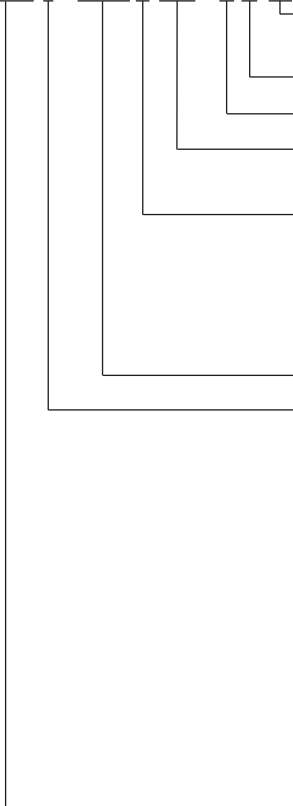

Electrical and mechanical variants*

M = connector version M8 / M12

Number of magnets: 1 - 5

Resolution = 1 µm
(Adjustable via EtherCAT)

Signal sense:

S = positively ascending on movement from the flange towards rod end
(Adjustable via EtherCAT)

Measuring stroke in mm

Design

MSK (rod):

1 = with threaded connection M 18 x 1.5

2 = with threaded connection 16 UNF ¼"

MPK (profile):

1 = position slider central ball joint

2 = position slider front ball joint

3 = liftable position magnet

Model

MPK = profile version

MSK = rod version

* The basic versions according to the data sheet bear the number 01. Deviations are identified with a variant number and are documented in the factory.

Scope of delivery:

Rod: Sensor, nut (order magnet separately)

Profile: Sensor, 1 position magnet, 2 mounting clamps up to 1250 mm + 1 clamp for each additional 500 mm.

Accessories:

■ Position magnets for MSK

PR02 Standard position ring (ø 33 mm)

PR03 Liftable position magnet

■ Position magnets for MPK

PS01 Position slider, central ball joint

PS02 Position slider, ball joint at side

PR03 Liftable position magnet

■ Straight mating connector M (M8 / M12)

STK4GP81 EtherCAT IN/OUT (M12)

STK4GS64 24 VDC supply (M8)

■ Our recommendation:

Industrial Ethernet data cable with M12 connectors, D-coded, moulded on at both ends

KABEL-XXX-114 (XXX = length in metres)

Standard lengths: 1, 2, 3 and 5 m

■ **KABEL-XXX-118:** Ethernet data cable M12 on RJ45 IP20 (XXX = length in metres)

■ Installation material:

MB-MP-01 Mounting clamps for profile version

NT-MP-01 M5 sliding block for profile version

ML-MSX Mounting shackle for rod version

Electrical connections version M (M8/M12)

Connection M8 (24 VDC)

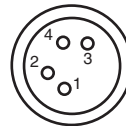

Socket: View of the clamping side of the mating connector.

PIN	Signal
1	+ UB (+24 VDC)
2	not assigned
3	- UB (0 VDC)
4	not assigned

Connection M12 (bus IN/OUT)

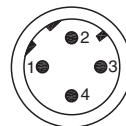

Pins: View of the clamping side of the mating connector.

PIN	Signal	Colour *
1	Tx +	yellow
2	Rx +	white
3	Tx -	orange
4	Rx -	blue

* Industrial Ethernet cable colours according to ISO / IEC 8802-3.

Further documentation:

On www.twk.de:

- MWA 10318 installation instructions
- EtherCAT manual MXK 11809
- Available position magnets MXX 11469

On www.ethercat.org:

- Specifications, introduction to EtherCAT, publications...

Dimensions in mm

Model: **MSK** (rod version)

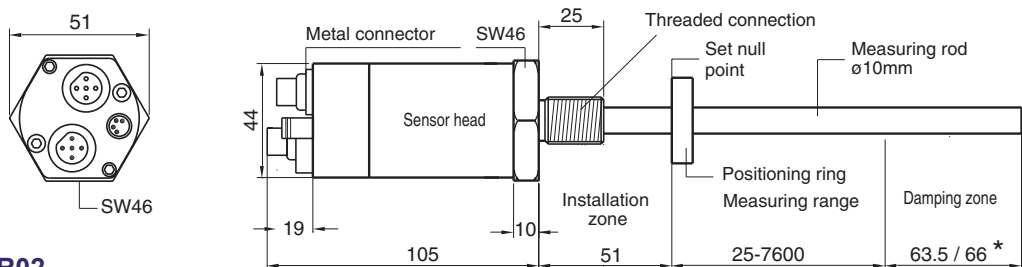

Standard position ring **PR02**

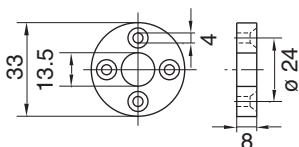

With measuring strokes of 1000 mm and over, mechanical rod support is recommended.
The sensor's fastening should be manufactured from non-magnetic materials (e.g.: brass, plastic).
Note installation instruction **MWA10318** on installation in magnetisable materials.

* Measuring length > 5000 mm

Model: **MPK** (profile version)

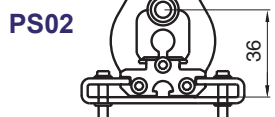
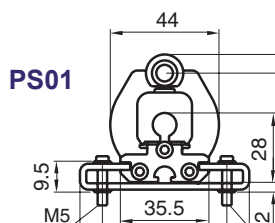

Central ball joint
PS01

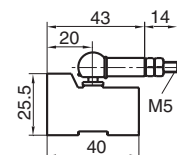

Front ball joint
PS02

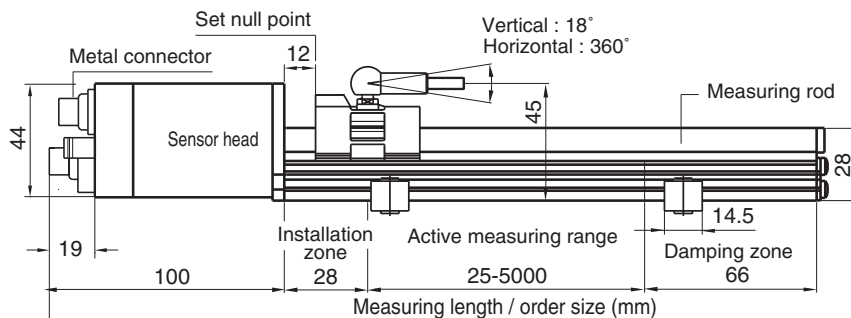
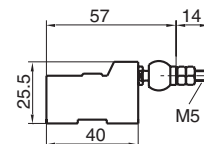

Liftable position magnet **PR03**

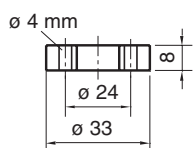
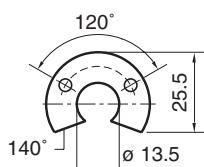
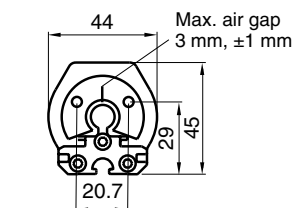

Liftable position magnet: Wherever possible, use non-magnetisable material for fastening this. If magnetisable material is used, the position magnet must be mounted via a non-magnetisable spacer washer with a minimum thickness of 5 mm using non-magnetisable bolts.

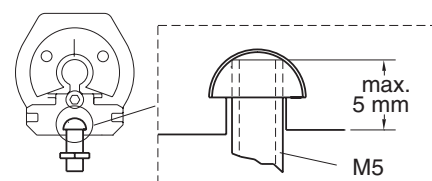
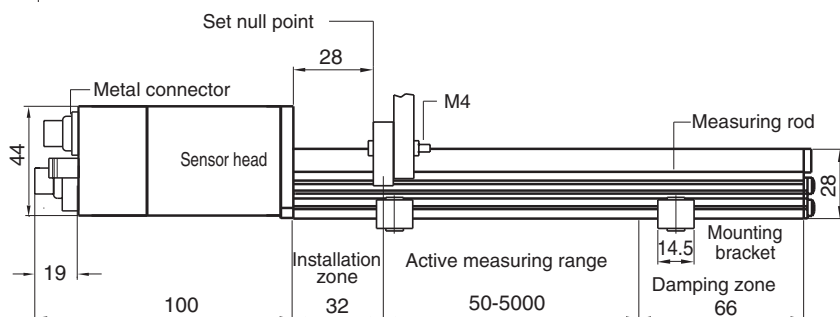

Sliding block: Studded nut in T slot

Note: On installation of the MAGNOSENS, careful shielding from magnetic and electromagnetic fields must be ensured. The cable shield must be mounted on the connector and connected to ground at the evaluation electronics.