

Catalog

Current sensors, voltage sensors and voltage detectors

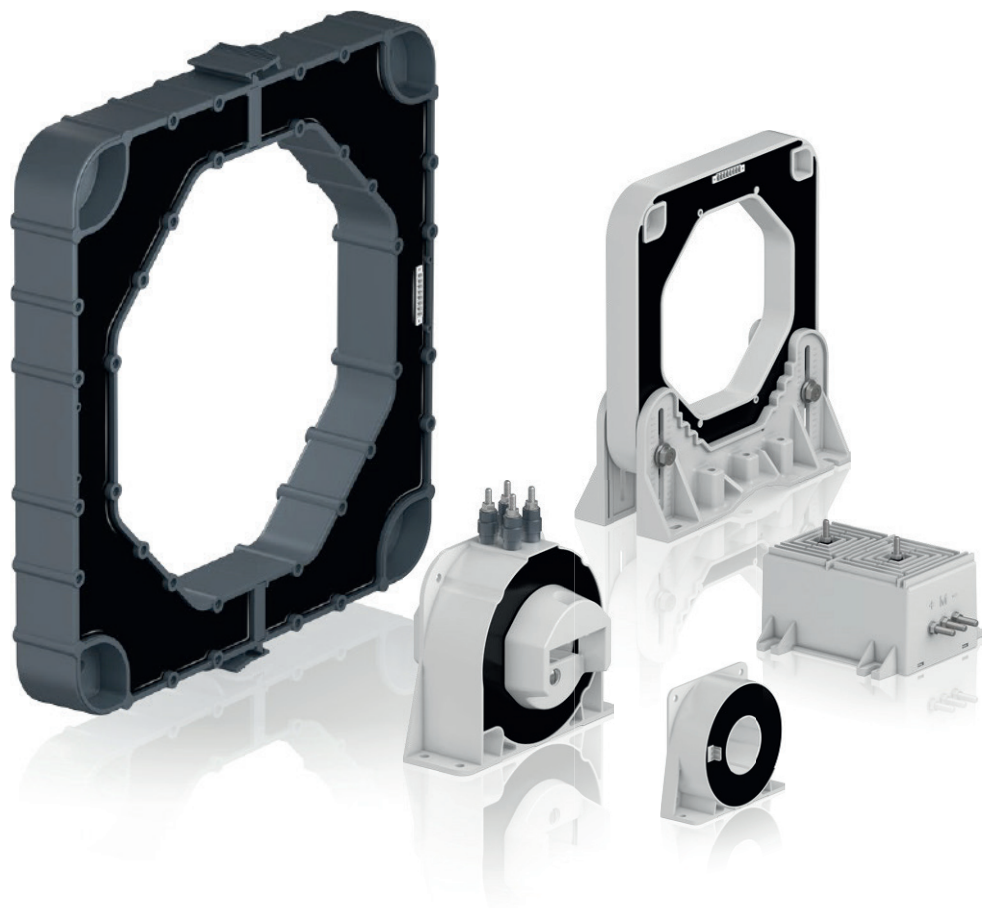

Current sensors, voltage sensors and voltage detectors

<u>Overview</u>	3	1
<u>Industry applications</u>	13	2
<u>Railway applications</u>	53	3
<u>General technical data</u>	89	4
<u>Questionnaire</u>	107	5
<u>Index</u>	112	6

Current and voltage measurement expertise from PETERCEM

Competence that you can rely on

Profit from our global network and 40 years of experience in current and voltage measurements. As an expert in electrical engineering, we offer sensors that can handle rough applications like rail, mining, offshore windmills, compact drive solutions and many more.

1

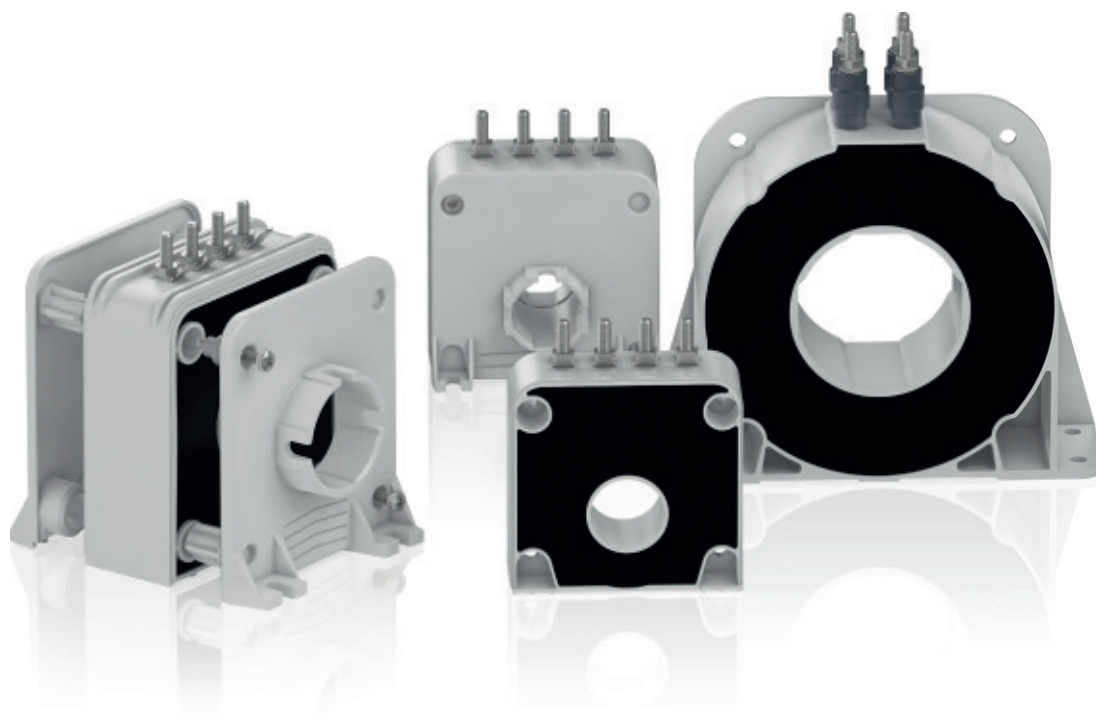

Speed up your projects

Don't spend your time searching for another partner, select current and voltage sensors to measure DC, AC and pulsating current.

Add other low voltage products to your order and get all the components you need from PETERCEM.



Reliable in extreme conditions

Years of product development and improvements allow us to offer you a product operating from $-40\text{ }^{\circ}\text{C}$ up to $+85\text{ }^{\circ}\text{C}$.

Thanks to their specific designs, which prevents electric and magnetic perturbations, our sensors can be implemented into compact systems or next to high current or voltage bus bars.



Continuous operation

For precise energy metering PETERCEM sensors guarantee very low accuracy error under 0.5% over frequencies up to 100 kHz. Allowing your installation to run in a reliable and efficient way.

Get high dynamic performances with representative outputs correctly followed up to $100\text{ A}/\mu\text{s}$ and $50\text{ V}/\mu\text{s}$.

Sensor panorama

Measure DC, AC or pulsating currents and voltages with a galvanic insulation

1

Current measurement - Hall effect technology

Closed loop

MP25



EL100



CS300

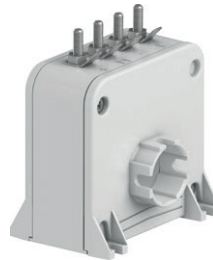

ES



5 A

2 000 A

Voltage measurement

Full electronic technology

VS50

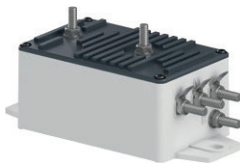

VS4200

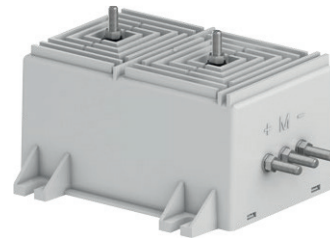

50 V

4 200 V

Railway applications

Full electronic technology

Dedicated products meeting main railway standards.
Current measurement from 100 A to 40 000 A.
Voltage measurement from 50 V to 4 200 V.



CS2000



VS4200

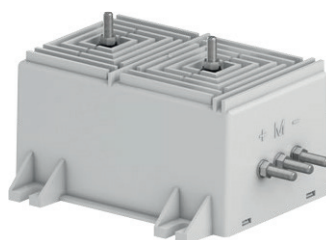

VD1500



Open loop



HBO

100 A

Full electronic



NCS125

4 000 A



NCS305

40 000 A

Voltage detection Full electronic technology

Maintenance personnel warning from dangerous voltages.
Very good visibility thanks to red colored LEDs.
Complies with main railway standards.

VD1500



25 V

VD3000



3 600 V

Three technologies for measuring current

1. Closed loop Hall effect technology

1

Principle

PETERCEM current sensors based on closed loop Hall effect technology are electronic transformers.

They allow for the measurement of direct, alternating and impulse currents, with galvanic insulation between the primary and secondary circuits.

The primary current I_p flowing across the sensor creates a primary magnetic flux.

The magnetic circuit channels this magnetic flux. The Hall probe placed in the air gap of the magnetic circuit provides a voltage proportional to this flux.

The electronic circuit amplifies this voltage and converts it into a secondary current I_s . This secondary current multiplied by the number of turns N_s of secondary winding cancels out the primary magnetic flux that created it (contra reaction). The formula $N_p \times I_p = N_s \times I_s$ is true at any time. The current sensor measures instantaneous values.

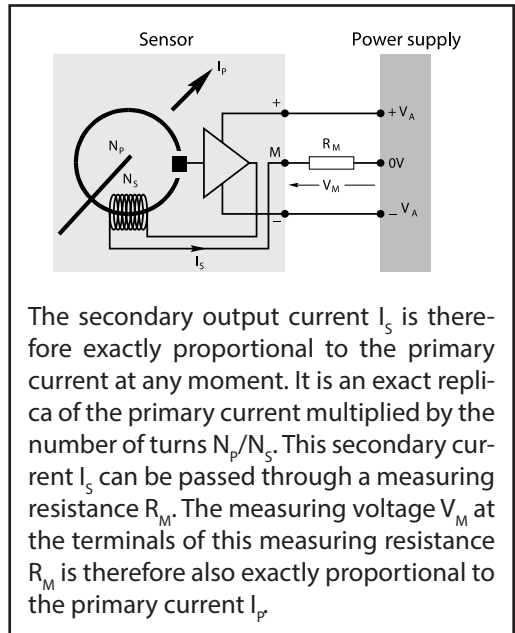
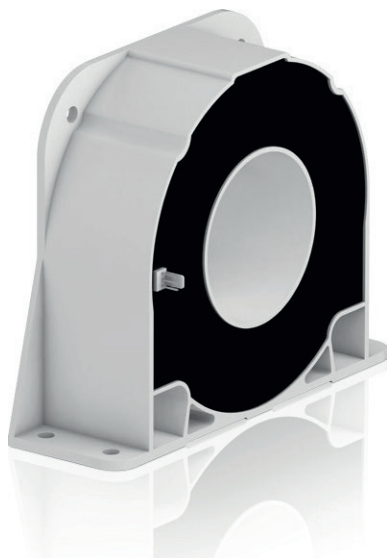

The secondary output current I_s is therefore exactly proportional to the primary current at any moment. It is an exact replica of the primary current multiplied by the number of turns N_p/N_s . This secondary current I_s can be passed through a measuring resistance R_M . The measuring voltage V_M at the terminals of this measuring resistance R_M is therefore also exactly proportional to the primary current I_p .

Advantages

The main advantages of this closed loop Hall effect technology are as follows:

- Galvanic insulation between the primary and secondary circuits
- Measurement of all waveforms is possible: direct current, alternating current, impulse, etc.
- High accuracy over a large frequency range (from direct to more than 100 kHz)
- High dynamic performance
- High overload capacities
- High reliability.

Applications

Industry

Variable speed drives, Uninterruptible Power Suppliers (UPS), active harmonic filters, battery chargers, wind generators, robotics, conveyers, lifts, cranes, solar inverter, elevator, etc.

Railway

Main converters, auxiliary converters (lighting, air conditioning), battery chargers, choppers, substations, mining, etc.

2. Electronic technology

Principle

PETERCEM current sensors are based on entirely electronic technology. In contrast to closed or open loop Hall effect technology, no magnetic circuit is used in the sensor.

They allow for the measurement of direct, alternating and impulse currents with galvanic insulation between the primary and secondary circuits.

The primary current I_p flowing across the sensor creates a primary magnetic flux. The different Hall probes included in the sensor measure this magnetic flux. The electronic circuit conditions and treats these signals (summation and amplification) to provide two output currents I_{s1} and I_{s2} and/or two output voltages V_{s1} and V_{s2} . All the outputs are exactly proportional to the measured primary current.

The current sensor measures instantaneous values.

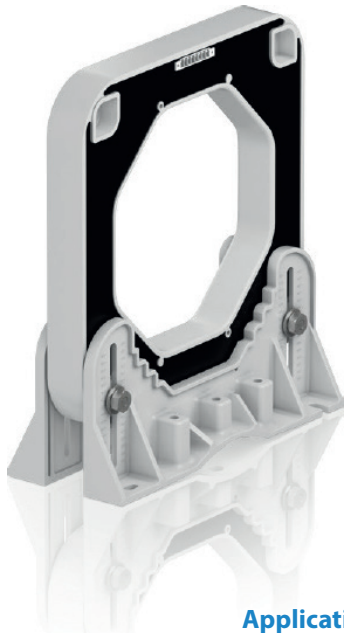

Advantages

The main advantages of this electronic technology are as follows:

- Galvanic insulation between the primary and secondary circuits
- Measurement of all waveforms is possible: direct current, alternating current, impulse, etc.
- Choice of output type (current or voltage, IPN or IPMAX)
- Very large current measuring range (up to 40 kA) without overheating the sensor
- High dynamic performance
- Low power consumption
- Reduced weight and volume
- Simplified mechanical fixing

Applications

Industry

Electrolysis, rectifiers, welding, etc.

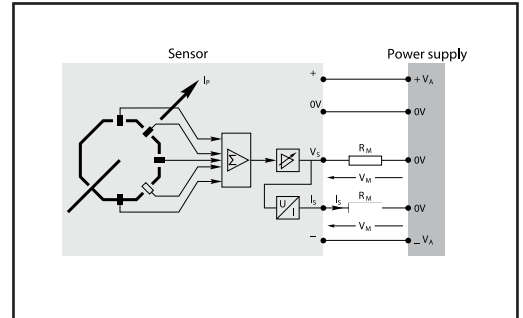

Railway

Substations in continuous voltage.

Three technologies for measuring current

3. Open loop Hall effect technology

1

Principle

PETERCEM current sensors based on open loop Hall effect technology are also electronic transformers. They allow for the measurement of direct, alternating and impulse currents, with galvanic insulation between the primary and secondary circuits.

The primary current I_p flowing across the sensor creates a primary magnetic flux.

The magnetic circuit channels this magnetic flux. The Hall probe placed in the air gap of the magnetic circuit provides a voltage V_H proportional to this flux, which is itself proportional to the current I_p to be measured.

The electronic circuit amplifies this Hall voltage (V_H) allowing it to be directly exploited by the operator as a secondary output voltage V_S .

The current sensor measures instantaneous values.

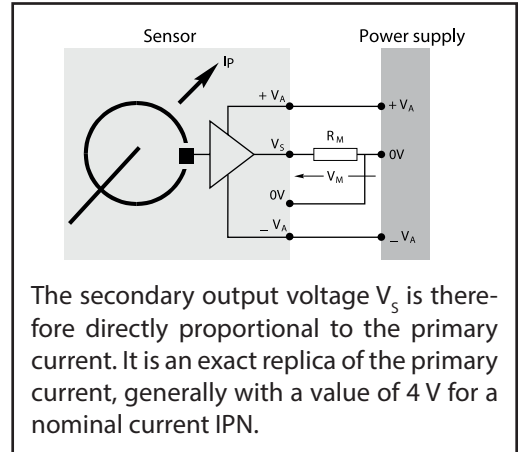

The secondary output voltage V_S is therefore directly proportional to the primary current. It is an exact replica of the primary current, generally with a value of 4 V for a nominal current I_{PN} .



Advantages

The main advantages of this open loop Hall effect technology are as follows:

- Galvanic insulation between the primary and secondary circuits.
- Measurement of all waveforms is possible: direct current, alternating current, impulse, etc.

— Good accuracy over a medium frequency range (from direct to several tens of kHz).

- High reliability.
- Low power consumption.
- Reduced weight and volume.
- Excellent Performance/Cost ratio.

Applications

Industry

Variable speed drives, backups ("UPS"), active harmonic filters, battery chargers, conveyers, lifts, cranes, solar inverter, etc.

Two technologies for measuring voltage

1. Electronic technology

Principle

PETERCEM voltage sensors based on electronic technology only use electronic components. In contrast to closed or open loop Hall effect technology, no magnetic circuits or Hall effect probes are used in the sensor.

This allows for the measurement of direct or alternating voltages with electrical insulation between the primary and secondary circuits.

The primary voltage to be measured is applied directly to the sensor terminals: HT+ (positive high voltage) and HT- (negative high voltage or earth). This voltage is passed through an insulating amplifier and is then converted to a secondary output current I_s . This secondary current I_s is electrically insulated from the primary voltage to which it is exactly proportional.

The voltage sensor measures instantaneous values.

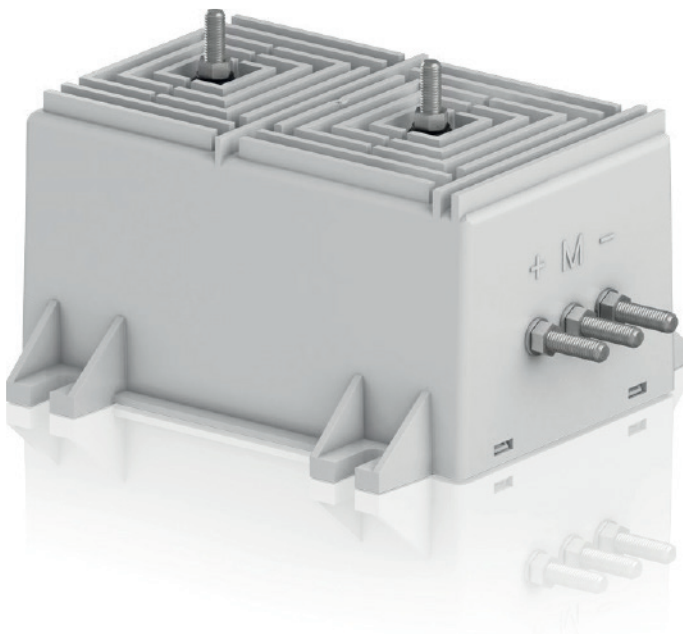

Advantages

The main advantages of this fully electronic technology are as follows:

- Electrical insulation between the primary and secondary circuits.
- Measurement of all waveforms is possible: direct voltage, alternating voltage, impulse, etc.

- Excellent immunity to electromagnetic fields.
- Excellent accuracy.
- High dynamic performance.
- Excellent reliability.

Applications

Railway

Main converters, auxiliary converters (lighting, air conditioning), battery chargers, choppers, substations, mining, etc.

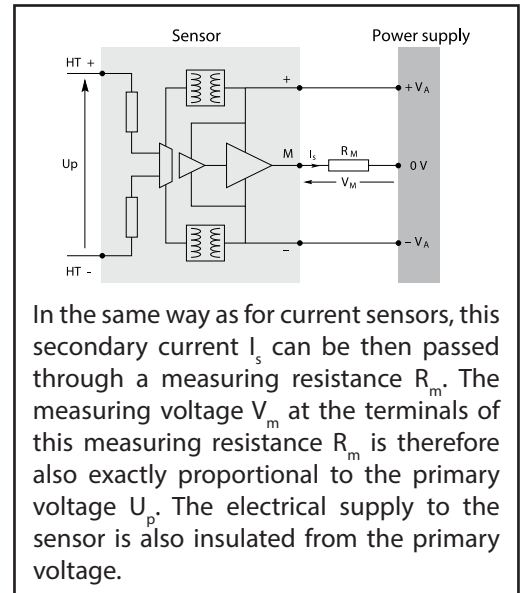

In the same way as for current sensors, this secondary current I_s can be then passed through a measuring resistance R_m . The measuring voltage V_m at the terminals of this measuring resistance R_m is therefore also exactly proportional to the primary voltage U_p . The electrical supply to the sensor is also insulated from the primary voltage.

Two technologies for measuring voltage

2. Closed loop Hall effect technology

1

Principle

PETERCEM voltage sensors based on closed loop Hall effect technology are also electronic transformers. They allow for the measurement of direct, alternating and impulse voltages with galvanic insulation between the primary and secondary circuits.

The primary voltage U_p to be measured is applied directly to the sensor terminals: HT+ (positive high voltage) and HT- (negative high voltage). An input resistance R_E must necessarily be placed in series with the resistance R_p of the primary winding to limit the current I_p and therefore the heat dissipated from the sensor. This resistance R_E may be either integrated during the manufacturing of the product (calibrated sensor) or added externally by the user to determine the voltage rating (not calibrated sensor).

The primary current I_p flowing across the primary winding via this resistance R_E generates a primary magnetic flux. The magnetic circuit channels this magnetic flux. The Hall probe placed in the air gap of the magnetic circuit provides a voltage V_H proportional to this flux.

The electronic circuit amplifies this voltage and converts it into a secondary current I_s . This secondary current multiplied by the number of turns N_s of secondary winding cancels out the primary magnetic flux that created it (contra reaction). The formula $N_p \times I_p = N_s \times I_s$ is true at any time.

The voltage sensor measures instantaneous values.

The secondary output current I_s is therefore exactly proportional to the primary voltage at any moment. It is an exact replica of the primary voltage. This secondary current I_s is passed through a measuring resistance R_M . The measuring voltage V_M at the terminals of this measuring resistance R_M is therefore also exactly proportional to the primary voltage U_p .

Advantages

The main advantages of this closed loop Hall effect technology are as follows:

- Galvanic insulation between the primary and secondary circuits.
- Measurement of all waveforms is possible: direct voltage, alternating voltage, impulse, etc.
- High accuracy.

Applications

Railway

Main converters, auxiliary converters (lighting, air conditioning), battery chargers, choppers, substations, mining, etc.

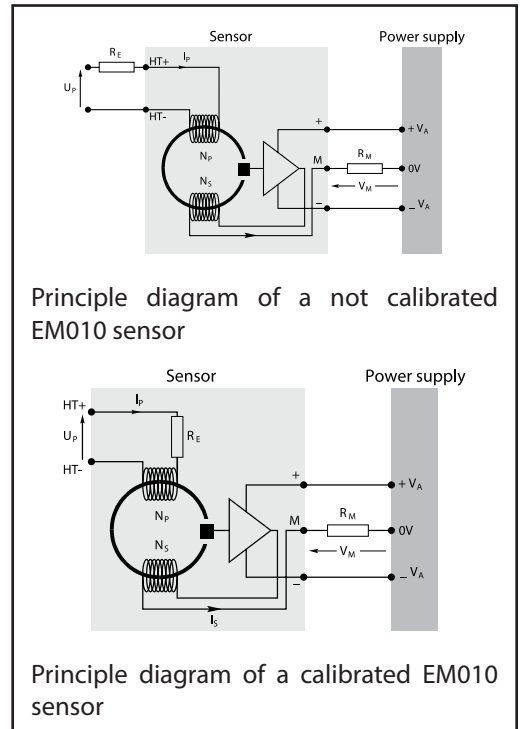

Voltage detection technology

1. Electronic technology

Principle

PETERCEM voltage detector is based on entirely electronic technology. It allows the detection of the presence of direct voltages. For safety reasons this main function is duplicated within the detector to increase the product lifetime.

The voltage detector converts the primary voltage U_p applied to its terminals to visual information for the user. This function permits the user to carry out maintenance operations with the assurance that dangerous voltage is not present.

The primary voltage U_p to be measured is applied directly to the detector terminals: HT1+ and HT2+ (positive high voltage) and HT1- and HT2- (negative high voltage or 0 V electric). The electronic circuit (PCB) converts the primary voltage U_p to an electrical signal supplied to a light emitting diode (LED). The information is supplied to the user visually through two flashing LEDs. The detector does not need an external power supply in order to work.



Advantages

The main advantages of this electronic technology are as follows:

- Detection of direct voltages.
- Very good visual indication.
- High overload capacities.
- Excellent reliability (functional redundancy in a single product).
- Excellent immunity to magnetic fields.
- Compact product.

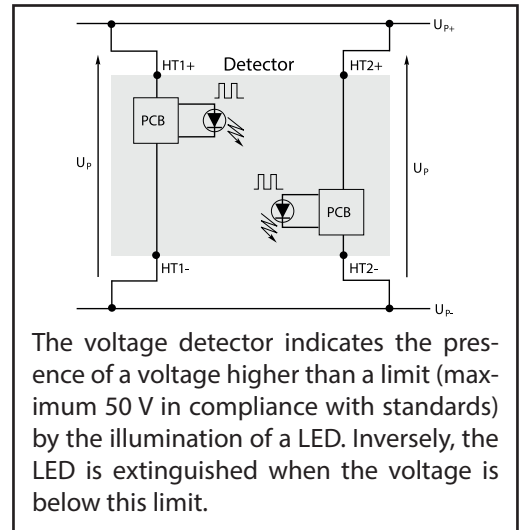

The voltage detector indicates the presence of a voltage higher than a limit (maximum 50 V in compliance with standards) by the illumination of a LED. Inversely, the LED is extinguished when the voltage is below this limit.

Applications

Railway

Main converters, auxiliary converters (lighting, air conditioning), electronic power devices integrating capacitors banks, battery chargers, choppers, substations, etc.



Current sensors Closed loop technology

Overview		14
MP25, EL25 ... EL100	5 to 100 A	16
ES100 ... ES2000	100 to 2000 A	17
Technical data		18
Dimensions		22

Electronic technology

Overview		24
NCS125 ... NCS165	4000 to 40000 A	26
NCS305	6000 to 40000 A	27
Technical data		28
Dimensions		34

Open loop technology

Overview		46
HBO100 ... HBO1000	100 to 1000 A	47
Technical data		48
Dimensions		50

Industry current sensors ES range

Closed loop technology

2



The resin concept: a reference that has become a standard

Since obtaining ISO 14001 certification in 1998 PETERCEM has integrated an essential concept into its ES current sensors: a determination to anticipate market requirements and genuine concern for the protection of the environment. This fundamental concern is the overwhelming culture that permeates the company. No wonder our competitors are jealous and find our approach an inspiration for their own efforts. With the introduction of recyclable resin, PETERCEM were trail-blazers

of an innovation that has over the years become a touchstone. It was this concept that enabled PETERCEM to obtain ISO 14001 certification for their concern for the environment. Optimized settings, waste control, minimization of losses, etc. are all factors that again ensure PETERCEM pride of place in the field of current sensors.

Smaller

As components get smaller but more powerful, installing current sensors is becoming a real problem. But with PETERCEM's ES range, the whole thing is child's play. By being the first in the field to offer these smaller current sensors that maintain your highperformance objectives, PETERCEM have met the challenge of giving you the space you always needed.



Horizontal or vertical mounting

Once again PETERCEM lead the field by giving installers a chance to choose between two ways of fastening sensors: horizontally or vertically. This flexibility means that ES sensors can be installed in any position.

This is a major breakthrough that greatly simplifies the task of systems integrators. The ES range is the ideal way of reducing the size of equipment.

Unbeatable reliability

Designed using the 6 sigma approach, the ES range is a model of reliability. The choice and number of optimized components, traceability of subassemblies, individually production tests... nothing is left to chance to guarantee your peace of mind.

	Sigma	Defects (PPM)	Performance
Unacceptable	2 σ	308 537	69.2 %
Average	3 σ	66 807	93.3 %
Very good	4 σ	6 210	99.4 %
Outstanding	5 σ	233	99.98 %
	6 σ	3.4	99.9996 %

A vast range of possibilities for every type of use

Because PETERCEM are in constant touch with their customers so that they can respond and adapt to the demands of the different sectors, they hold pride of place in their customers' list of partners. PETERCEM are totally at home in the world of power electronics, a world made up of target sectors that range from power converters and auxiliary converters, inverters, wind power generators, welding, robotics and active harmonic suppressors. PETERCEM's power lies in their ability to adapt.

2



Quality that goes beyond standards

PETERCEM have been ISO 9001 certified since 1993 and our ES range of sensors bear the CE label in Europe and the UL or UR labels in the US.

This ongoing striving after quality has always been the hallmark of a company where excellence and safety are part of the culture, from design right through to production. This culture is the result of continuous research to make technical progress and meet our customers' demands.

The chief selling-point of ES sensors is their quality. Compliance of their high-tech electronic design with standard EN 50178 is proof of their ability to comply with the most detailed constraint as well as major demands.

The fact that each individual sensor is subjected to rigorous testing is proof of the importance PETERCEM attribute to quality.

Environment-friendly

PETERCEM have long been concerned with the protection of the environment, as proved by the ISO 14001 certification they received

in 1998. This environmental approach is particularly noticeable in production of the ES range in the reduction of the number of components, in the use of a low-energy manufacturing procedure and the use of recyclable packing. The products in use are also characterized by their reduced energy consumption. Our ES range is RoHS compliant.



Because your needs are special we find you the best solution

MP25, EL25 ... EL100 industry current sensors

5 to 100 A - Closed loop technology

2

PCB mounting

These sensors are designed for PCB mounting.

The sensor is mechanically fixed by soldering the secondary circuit pins to the PCB.

The primary connection can also be integrated in the sensor (pins for MP sensors, integrated primary bar for EL...BB sensors).

The primary conductor for EL sensors can also be a cable or a bar.

For MP sensors the primary pin combination determines the sensor's nominal rating (see technical data).

Ordering details



MP25P1

Nominal primary current	Secondary current at I_{PN}	Supply voltage	Primary connection	Secondary connection	Type	Order code
A r.m.s. 5 to 25*	mA 24 or 25*	VDC $\pm 12 \dots \pm 15$	Pins	3 pins	MP25P1	1SBT312500R0001



EL25P1 to 100P2

Nominal primary current	Secondary current at I_{PN}	Supply voltage	Primary connection	Secondary connection	Type	Order code
A r.m.s. 25	mA 25	VDC $\pm 12 \dots \pm 15$	Hole $\varnothing 7.5 \text{ mm}$	3 pins	EL25P1	1SBT132500R0001
25	25	$\pm 12 \dots \pm 15$	Bar	3 pins	EL25P1BB	1SBT132500R0002
50	50	$\pm 12 \dots \pm 15$	Hole $\varnothing 10 \text{ mm}$	3 pins	EL50P1	1SBT135100R0001
50	50	$\pm 12 \dots \pm 15$	Bar	3 pins	EL50P1BB	1SBT135100R0003
50	25	$\pm 12 \dots \pm 15$	Hole $\varnothing 10 \text{ mm}$	3 pins	EL55P2	1SBT135100R0002
50	25	$\pm 12 \dots \pm 15$	Bar	3 pins	EL55P2BB	1SBT135100R0004
100	50	$\pm 12 \dots \pm 15$	Hole $\varnothing 10 \text{ mm}$	3 pins	EL100P2	1SBT130100R0001
100	50	$\pm 12 \dots \pm 15$	Bar	3 pins	EL100P2BB	1SBT130100R0002

* see technical data "MP25P1: arrangement of primary terminals and related characteristics".

ES100 ... ES2000 industry current sensors

100 to 2000 A - Closed loop technology

Frame mounting

These sensors are designed to be fixed by the case. They may be either horizontally or vertically mounted. The secondary connection is made with a connector or cable. For ES sensors the primary conductor may be a cable or a bar.



ES100C



ES300C



ES500C



ES1000S



ES2000C

Ordering details

Nominal primary current	Secondary current at I_{PN}	Supply voltage	Secondary connection	Type	Order code
A r.m.s.	mA	VDC			
100	100	$\pm 12 \dots \pm 24$	Molex type 3 pins HE 14	ES100C	1SBT150100R0001
100	100	$\pm 12 \dots \pm 24$	3 wires 200 mm	ES100F	1SBT150100R0002
300	150	$\pm 12 \dots \pm 24$	Molex type 3 pins HE 14	ES300C	1SBT150300R0001
300	150	$\pm 12 \dots \pm 24$	JST 3 pins	ES300S	1SBT150300R0003
300	150	$\pm 12 \dots \pm 24$	3 wires 200 mm	ES300F	1SBT150300R0002
500	100	$\pm 12 \dots \pm 24$	Molex type 3 pins HE 14	ES500C	1SBT150500R0001
500	100	$\pm 12 \dots \pm 24$	JST 3 pins	ES500S	1SBT150500R0003
500	100	$\pm 12 \dots \pm 24$	3 wires 200 mm	ES500F	1SBT150500R0002
500	125	$\pm 12 \dots \pm 24$	Molex type 3 pins HE 14	ES500-9672	1SBT150500R9672
500	125	$\pm 12 \dots \pm 24$	JST 3 pins	ES500-9673	1SBT150500R9673
500	125	$\pm 12 \dots \pm 24$	3 wires 200 mm	ES500-9674	1SBT150500R9674
1000	200	$\pm 12 \dots \pm 24$	Molex type 3 pins HE 14	ES1000C	1SBT151000R0001
1000	200	$\pm 12 \dots \pm 24$	JST 3 pins	ES1000S	1SBT151000R0003
1000	200	$\pm 12 \dots \pm 24$	3 wires 200 mm	ES1000F	1SBT151000R0002
1000	250	$\pm 12 \dots \pm 24$	Molex type 3 pins HE 14	ES1000-9678	1SBT151000R9678
1000	250	$\pm 12 \dots \pm 24$	JST 3 pins	ES1000-9679	1SBT151000R9679
1000	250	$\pm 12 \dots \pm 24$	3 wires 200 mm	ES1000-9680	1SBT151000R9680
2000	400	$\pm 15 \dots \pm 24$	Molex type 3 pins HE 14	ES2000C	1SBT152000R0003
2000	400	$\pm 15 \dots \pm 24$	JST 3 pins	ES2000S	1SBT152000R0002
2000	400	$\pm 15 \dots \pm 24$	3 wires 200 mm	ES2000F	1SBT152000R0001

MP25, EL25 ... EL100 industry current sensors

Technical data

2

Utilisation

Sensors to measure DC, AC or pulsating currents with a galvanic insulation between primary and secondary circuits.

Type MP25P1: the rating (from 5 to 25 A) is determined via a combination of the primary connections (see technical data: "Arrangement of primary terminals and related characteristics").

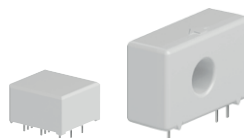

	Without primary bus bar		–	EL25P1	EL50P1	EL55P2	EL100P2
	With primary bus bar		MP25P1	EL25P1BB	EL50P1BB	EL55P2BB	EL100P2BB
Nominal primary current		A r.m.s.	See technical data	25	50	50	100
Measuring range	@ ±15 V (±5%)	A		±55	±80	±80	±145
Max. measuring resistance	@ I _{PMAX} & ±15 V (±5%)	Ω	216	142	78	93	29
Min. measuring resistance	@ I _{PN} & ±15 V (±5%) & 70 °C	Ω	100	100	75	10	20
Min. measuring resistance	@ I _{PN} & ±12 V (±5%) & 70 °C	Ω	0	0	15	0	0
Turn number			See technical data	1000	1000	2000	2000
Secondary current at I _{PN}		mA		25	50	25	50
Rms accuracy at I _{PN}	-20 ... +70 °C, sinus 50 Hz	%	≤±0.5	≤±0.5	≤±0.5	≤±0.5	≤±0.5
Offset current	@ +25 °C	mA	≤±0.1	≤±0.2	≤±0.2	≤±0.2	≤±0.2
Linearity		%	≤0.1	≤0.1	≤0.1	≤0.1	≤0.1
Thermal drift coefficient	-20 ... +70 °C	µA/°C	7	7	7	7	7
Delay time		µs	≤0.1	≤0.1	≤0.1	≤0.1	≤0.1
di/dt correctly followed		A / µs	≤100	≤200	≤200	≤150	≤150
Bandwidth	-1 dB	kHz	≤150	≤200	≤200	≤150	≤150
Max. no-load consumption current	@ ±15 V (±5%)	mA	≤18	≤20	≤20	≤20	≤20
Secondary resistance	@ +70 °C	Ω	≤96	≤63	≤63	≤188	≤126
Dielectric strength Primary/Secondary	50 Hz, 1 min	kV	2.5	3	3	3	3
Supply voltage	±5%	VDC	±12 ... ±15	±12 ... ±15	±12 ... ±15	±12 ... ±15	±12 ... ±15
Voltage drop		V	≤3	≤3	≤3	≤3	≤3
Mass (EL type)		kg	–	0.020	0.020	0.020	0.020
Mass (MP and EL...BB types)		kg	0.027	0.027	0.027	0.027	0.027
Operating temperature		°C	-20 ... +70	-20 ... +70	-20 ... +70	-20 ... +70	-20 ... +70
Storage temperature		°C	-25 ... +85	-25 ... +85	-25 ... +85	-25 ... +85	-25 ... +85

General data

Direction of the current

— **MP25P1 type:** A primary current flowing from pins 1- 5 to pins 6-10 results in a positive secondary output current from terminal M

— **EL type:** A primary current flowing in the direction of the arrow results in a positive secondary output current from terminal M.

Fixing

By soldering pins on printed circuit board.

Primary connection

— **MP25P1 type:** By 10 soldering pins

— **EL type:** Hole for primary conductor (the temperature of the primary conductor in contact with the case must not exceed 100 °C)

— **EL...BB type:** Primary bar included.

Secondary connection

3 soldering pins.

Unit packing

— **MP25P1 type:** 40 per pack

— **EL type:** 50 per pack

— **EL...BB type:** 25 per pack.

Conformity

RoHS

MP25, EL25 ... EL100 industry current sensors

Technical data

MP25P1: Arrangement of primary terminals and related characteristics

Nominal primary current A r.m.s.	Measuring range @ $\pm 15\text{ V } (\pm 5\%)$ A peak	Secondary current at I_{PN} mA	Turn ratio N_P/N_S	Primary resistance m Ω	Primary pin connections
25	± 36	25	1/1000	0.3	
12	± 18	24	2/1000	1.1	
8	± 12	24	3/1000	2.5	
6	± 9	24	4/1000	4.4	
5	± 7	25	5/1000	6.3	

2

Dimensions (mm)

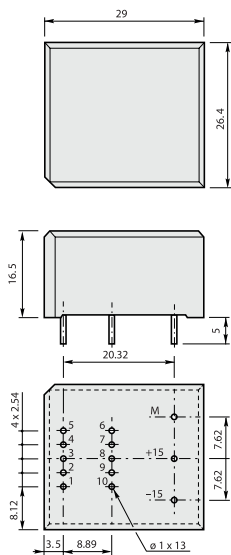

MP current sensors

General tolerance: $\pm 1\text{ mm}$

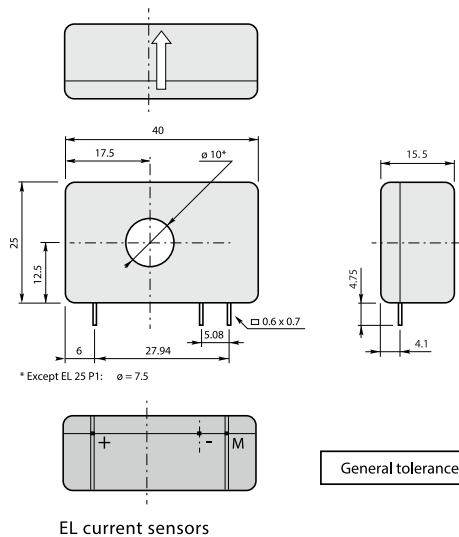

* Except EL 25 P1: $\phi = 7.5$

EL current sensors

General tolerance: $\pm 1\text{ mm}$

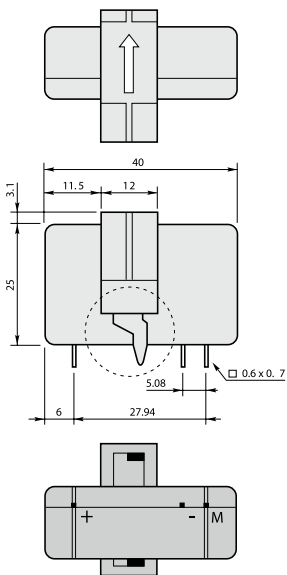

EL...BB current sensors

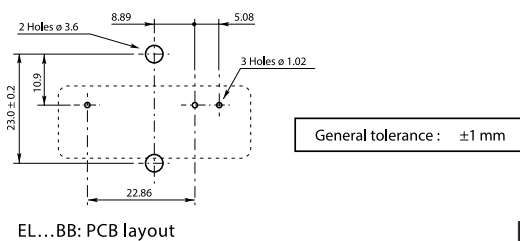
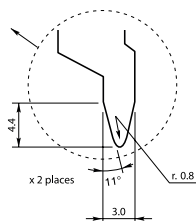

EL...BB: PCB layout

ES100 ... ES2000 industry current sensors

Technical data

2

Utilisation

Sensors to measure DC, AC or pulsating currents with a galvanic insulation between primary and secondary circuits.

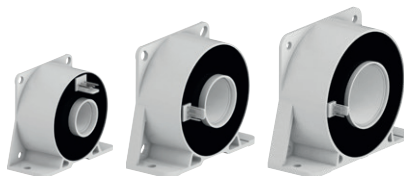

		Molex type HE14 connector	ES100C	ES300C	ES500C	ES500-9672
		JST connector	-	ES300S	ES500S	ES500-9673
		Cables	ES100F	ES300F	ES500F	ES500-9674
		A r.m.s.				
Nominal primary current			100	300	500	500
Measuring range	@ ±15 V (±5%)	A	±150	±500	±800	±800
Measuring range	@ ±24 V (±5%)	A	±150	±500	±800	±800
Not measurable overload	10 ms/hour	A	300 (1 ms/hour)	3000	5000	5000
Max. measuring resistance	@ I _{PMAX} & ±15 V (±5%)	Ω	48	20	7	13
Max. measuring resistance	@ I _{PMAX} & ±24 V (±5%)	Ω	105	54	60	56
Min. measuring resistance	@ I _{PN} & ±15 V (±5%)	Ω	10	0	0	0
Min. measuring resistance	@ I _{PN} & ±24 V (±5%)	Ω	82	45	0	14
Turn number			1000	2000	5000	4000
Secondary current at I _{PN}		mA	100	150	100	125
Accuracy at I _{PN}	@ +25 °C	%	≤±0.5	≤±0.5	≤±0.5	≤±0.5
Accuracy at I _{PN}	-5 ... +70 °C	%	≤±1	≤±1	≤±1	≤±1
Accuracy at I _{PN}	-20 ... +70 °C	%	≤±2.5	≤±1.5	≤±1	≤±1
Offset current	@ +25 °C	mA	≤±0.4	≤±0.25	≤±0.25	≤±0.25
Linearity		%	≤0.1	≤0.1	≤0.1	≤0.1
Thermal drift coefficient	-5 ... +70 °C	µA/°C	≤10	≤15	≤5	≤6.25
Thermal drift coefficient	-20 ... +70 °C	µA/°C	≤80	≤40	≤16	≤20
Delay time		µs	≤1	≤1	≤1	≤1
di/dt correctly followed		A / µs	≤50	≤50	≤100	≤100
Bandwidth	-1 dB	kHz	≤100	≤100	≤100	≤100
Max. no-load consumption current	@ ±24 V (±5%)	mA	≤12	≤12	≤12	≤12
Secondary resistance	@ +70 °C	Ω	≤30	≤33	≤76	≤53
Dielectric strength Primary/Secondary	50 Hz, 1 min	kV	3	3	3	3
Supply voltage	±5%	V DC	±12 ... ±24	±12 ... ±24	±12 ... ±24	±12 ... ±24
Voltage drop		V	≤2.5	≤1	≤1	≤1
Mass		kg	0.050	0.115	0.210	0.210
Operating temperature		°C	-20 ... +70	-20 ... +70	-20 ... +70	-20 ... +70
Storage temperature		°C	-40 ... +85	-40 ... +85	-40 ... +85	-40 ... +85

General data

- Plastic case and insulating resin are self-extinguishing
- Fixing holes in the case moulding for two positions at right angles
- Direction of the current: A primary current flowing in the direction of the arrow results in a positive secondary output current from terminal M.

Primary connection

Hole for primary conductor.
The temperature of the primary conductor in contact with the case must not exceed 100 °C.

Secondary connection

- Molex type HE14 connector
- JST connector (ref.: B3P-VH)
- 3 x 200 mm cables (cross section 0.38 mm²).



	Molex type HE14 connector		ES1000C	ES1000-9678	ES2000C
	JST connector		ES1000S	ES1000-9679	ES2000S
	Cables		ES1000F	ES1000-9680	ES2000F
		A r.m.s.			
Nominal primary current			1000	1000	2000
Measuring range	@ ±15 V (±5%)	A	±1500	±1500	±2200 (R _M =5 Ω)
Measuring range	@ ±24 V (±5%)	A	±1500	±1500	±3000
Not measurable overload	10 ms/hour	A	10000	10000	20000
Max. measuring resistance	@ I _{PMAX} & ±15 V (±5%)	Ω	4	7	-
Max. measuring resistance	@ I _{PMAX} & ±24 V (±5%)	Ω	33	30	11
Min. measuring resistance	@ I _{PN} & ±15 V (±5%)	Ω	0	0	0
Min. measuring resistance	@ I _{PN} & ±24 V (±5%)	Ω	0	0	0
Turn number			5000	4000	5000
Secondary current at I _{PN}		mA	200	250	400
Accuracy at I _{PN}	@ +25 °C	%	≤±0.5	≤±0.5	≤±0.5
Accuracy at I _{PN}	-5 ... +70 °C	%	≤±1	≤±1	≤±1
Accuracy at I _{PN}	-20 ... +70 °C	%	≤±1	≤±1	≤±1
Offset current	@ +25 °C	mA	≤±0.25	≤±0.25	≤±0.25
Linearity		%	≤0.1	≤0.1	≤0.1
Thermal drift coefficient	-5 ... +70 °C	μA/°C	≤5	≤6.25	≤10
Thermal drift coefficient	-20 ... +70 °C	μA/°C	≤20	≤20	≤10
Delay time		μs	≤1	≤1	≤1
di/dt correctly followed		A / μs	≤100	≤100	≤100
Bandwidth	-1 dB	kHz	≤100	≤100	≤100
Max. no-load consumption current	@ ±24 V (±5%)	mA	≤12	≤12	≤25
Secondary resistance	@ +70 °C	Ω	≤40	≤28	≤25
Dielectric strength Primary/Secondary	50 Hz, 1 min	kV	3	3	4
Supply voltage	±5%	VDC	±15 ... ±24	±15 ... ±24	±15 ... ±24
Voltage drop		V	≤1	≤1	≤1
Mass		kg	0.550	0.610	1.5
Operating temperature		°C	-20 ... +70	-20 ... +70	-20 ... +70
Storage temperature		°C	-40 ... +85	-40 ... +85	-40 ... +85

Accessories and options

Female Molex connector

— PETERCEM order code: **FPTN440032R0003** including 10 socket housings and 30 crimp socket contacts
 — Molex order code: socket housing: 22-01-1034; crimp socket contacts: 08-70-0057.

Female JST connector

— PETERCEM order code: **FPTN440032R0002** including 10 socket housings and 30 crimp socket contacts
 — JST order code: socket housing: VHR-3N; crimp socket contacts: SVH-21T-1.1.

Conformity

EN 50178

EN 61000-6-2, EN 61000-6-4



: ES sensors with cables.

File number: E166814 Vol 1



: ES sensors with connectors.

File number: E166814 Vol 2

RoHS

ES100 ... ES500 industry current sensors

Dimensions (mm)

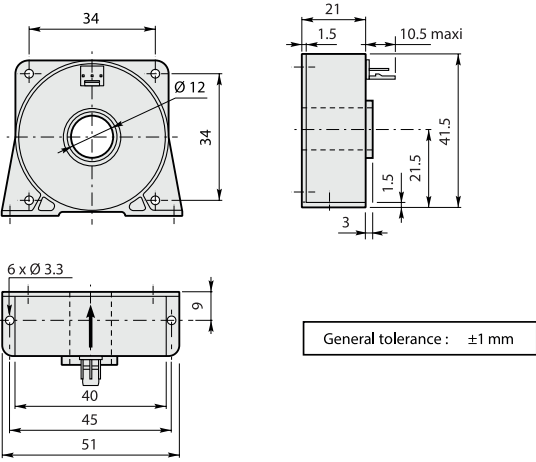

ES100C / ES100F

General tolerance : ±1 mm

Standard ES100... sensors secondary connection

Molex type connector
(with 2.54 mm pitch)

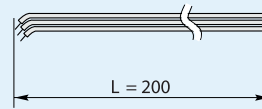

Cable: - Red +V_A
- Green M
- Black -V_A

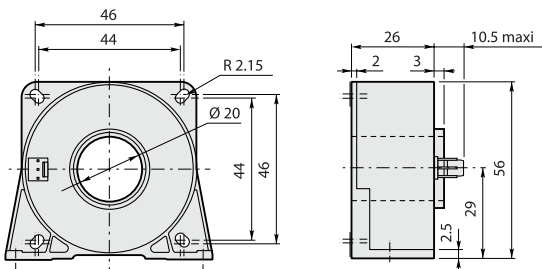

ES300C / ES300S / ES300F

General tolerance : ±1 mm

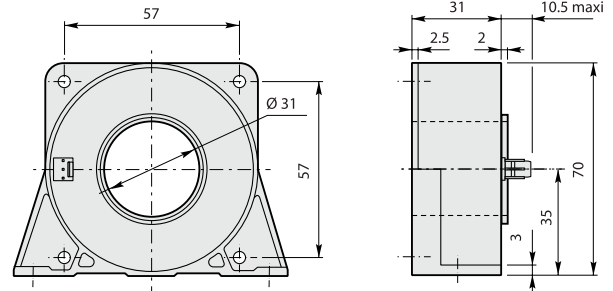

ES500C / ES500S / ES500F
ES500-9672 / ES500-9673 / ES500-9674

General tolerance : ±1 mm

Standard ES300... and ES500... sensors secondary connection

Molex type connector
(with 2.54 mm pitch)

JST connector
(with 3.96 mm pitch)

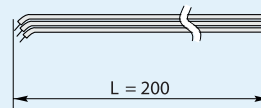

Cable: - Red +V_A
- Green M
- Black -V_A

ES1000 ... ES2000 industry current sensors

Dimensions (mm)

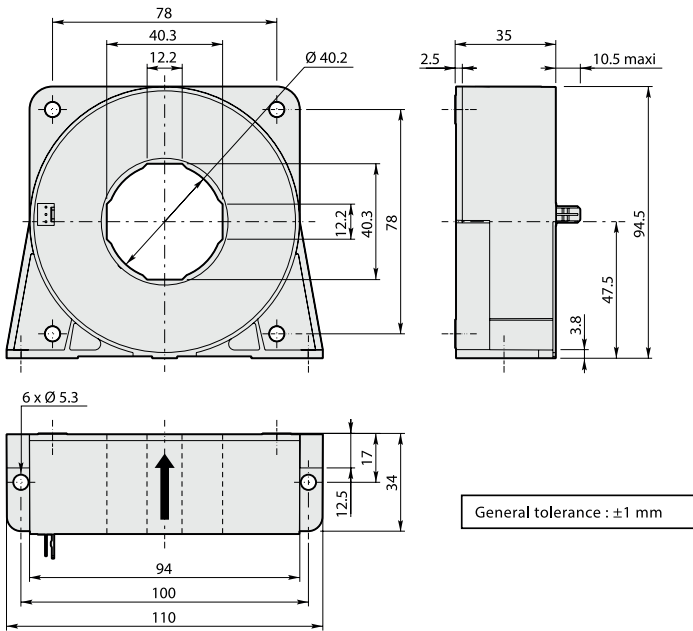

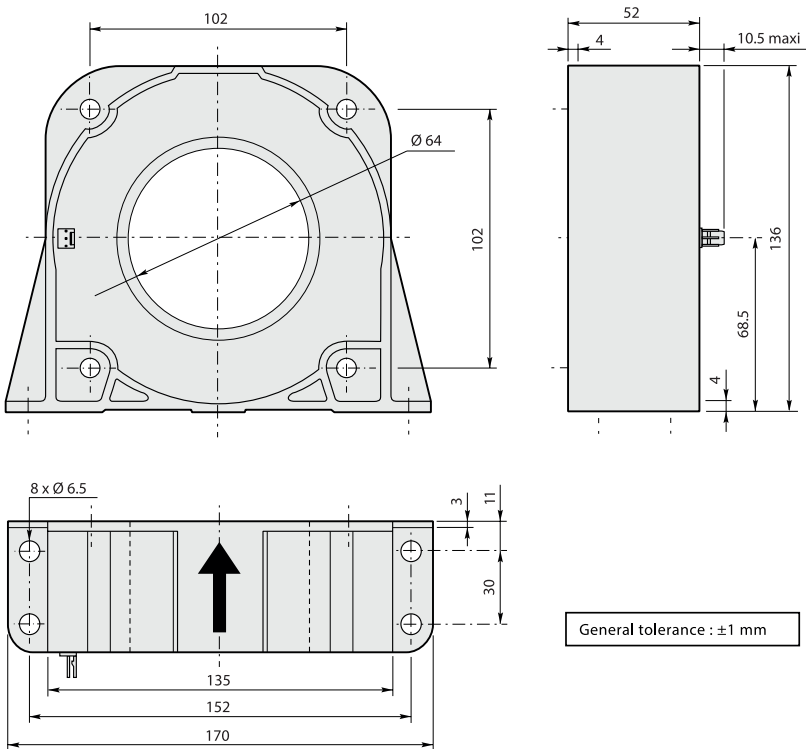

ES1000C / ES1000S / ES1000F
ES1000-9678 / ES1000-9679 / ES1000-9680



ES2000C / ES2000S / ES2000F

Standard ES1000... and ES2000... sensors secondary connection

 Molex type connector (with 2.54 mm pitch)

 JST connector (with 3.96 mm pitch)

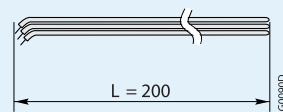

Cable: - Red +V_A
- Green M
- Black -V_A

Industry current sensors NCS range

Electronic technology

2

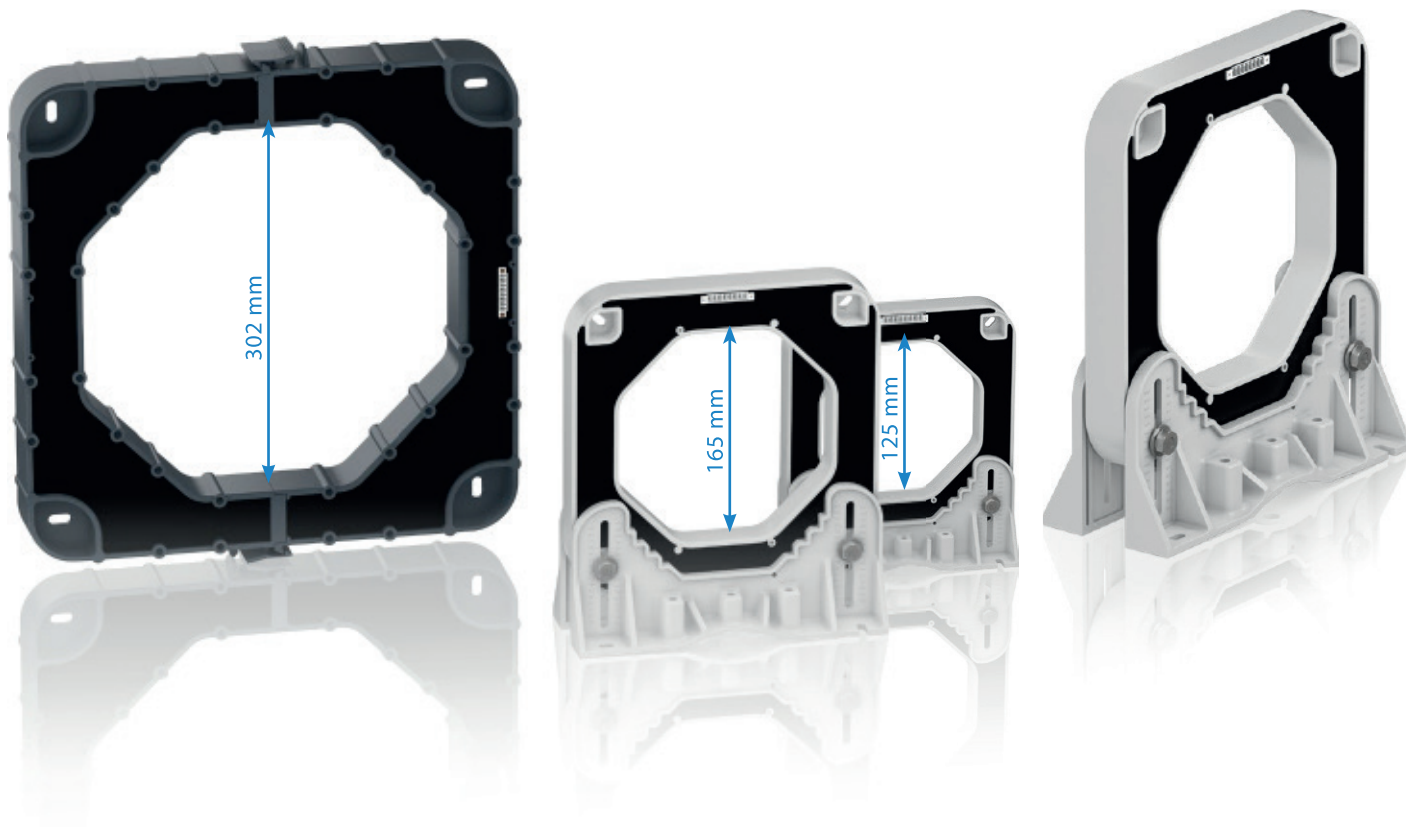

Designed to be integrated into every situation

The NCS125/165 sensor is entirely symmetrical. Its square shape and strategically positioned oblong holes make it easy to fasten in a choice of 2 positions.

As an accessory it comes with a side plate that can be fastened on either side of the sensor giving complete fitting flexibility. It meets the standard design of PETERCEM current sensors. It can be fitted both horizontally and vertically.

This flexibility means that NCS125/165 sensor simplifies the work of integrators. Additionally the pair of side plate allows the NCS125/165 sensor to be fitted to one or several bars at the same time.

The NCS305 sensor has been designed to reduce installation-costs for new and retrofit systems. Using our innovative and robust opening, the clip-on system allows the NCS305 to be easily adapted to existing bus bars.

Thanks to its core free, patented technology, the NCS is more cost effective and faster to install than traditional Hall Effect sensor.

The NCS is a “flyweight” with only 5.5 kg (for the NCS305), this sensor offer the best rating/weight ratio.

100% electronic

The main advantage of the NCS range of sensors is that they are designed using a brand-new solution: 100% electronic technology. Unlike other currently available solutions such as shunts and CTs, this approach means that these sensors are very compact. Several patents were necessary to achieve this improvement.

Considerable energy savings

NCS sensors offer considerable savings in energy. Indeed only a few watts are required to power the NCS sensor in contrast to traditional sensors that require several hundred watts. This reduction in wasted energy means there is no rise in temperature around the sensor.

Quality that goes beyond standards

PETERCEM have been ISO 9001 certified since 1993 and our standard NCS sensors bear the CE label in Europe. This ongoing striving after quality has always been the hallmark of a company where excellence and safety are part of the culture, from design right through to production. This culture is the result of continuous research to make technical progress and meet our customers' demands.

The chief selling-point of NCS sensors is their quality. Compliance of their high-tech electronic design with standard EN 50178 is proof of their ability to comply with the most detailed constraint as well as major demands. The fact that each individual sensor is subjected to rigorous testing is proof of the importance PETERCEM attribute to quality.

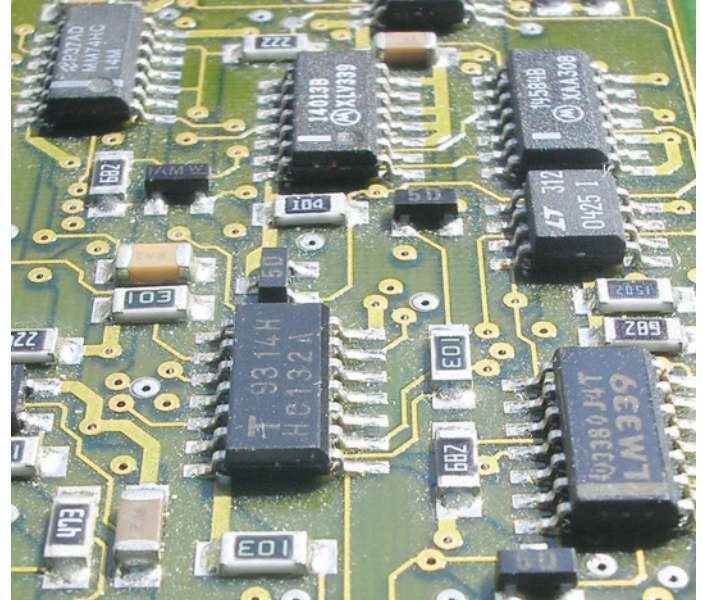

2

Environment-friendly

PETERCEM have long been concerned with the protection of the environment, as proved by the ISO 14001 certification they received in 1998. This environmental approach is particularly noticeable in the production of the NCS range in the reduction of the number of components, in the use of a low-energy manufacturing procedure and the use of recyclable packing. The products in use are also characterized by their reduced energy consumption.

Our NCS range is RoHS compliant.



The NCS meets all of your requirements

NCS125 ... NCS165 industry current sensors

4000 to 40000 A - Electronic technology

2

Frame mounting

These sensors are designed to be fixed by the case.
They may be either vertically or horizontally mounted.
The secondary connection is made with a connector or cable.
For NCS sensors the primary conductor may be a cable, one or several bars.



NCS125-4 to NCS125-10



NCS125-4AF to NCS125-10AF
NCS125-4VF to NCS125-10VF



NCS165-4 to NCS165-20



NCS165-4AF to NCS165-20AF
NCS165-4VF to NCS165-20VF

Ordering details

Nominal primary current	Opening for the primary conductor	Secondary current I_{S1} at $\pm I_{PN}$	Secondary voltage V_{S1} at $\pm I_{PN}$	Supply voltage	Secondary connection	Type	Order code
A	mm	mA	V	VDC			
4000	125	± 20	± 10	$\pm 15 \dots \pm 24$	Straight connector 8 pin	NCS125-4	1SBT200204R0001
4000	125	± 20	-	$\pm 15 \dots \pm 24$	Shielded cable 6 wires (2 m)	NCS125-4AF	1SBT200204R0002
4000	125	-	± 10	$\pm 15 \dots \pm 24$	Shielded cable 6 wires (2 m)	NCS125-4VF	1SBT200204R0102
4000	165	± 20	± 10	$\pm 15 \dots \pm 24$	Straight connector 8 pin	NCS165-4	1SBT200604R0001
4000	165	± 20	-	$\pm 15 \dots \pm 24$	Shielded cable 6 wires (2 m)	NCS165-4AF	1SBT200604R0002
4000	165	-	± 10	$\pm 15 \dots \pm 24$	Shielded cable 6 wires (2 m)	NCS165-4VF	1SBT200604R0102
6000	125	± 20	± 10	$\pm 15 \dots \pm 24$	Straight connector 8 pin	NCS125-6	1SBT200206R0001
6000	125	± 20	-	$\pm 15 \dots \pm 24$	Shielded cable 6 wires (2 m)	NCS125-6AF	1SBT200206R0002
6000	125	-	± 10	$\pm 15 \dots \pm 24$	Shielded cable 6 wires (2 m)	NCS125-6VF	1SBT200206R0102
6000	165	± 20	± 10	$\pm 15 \dots \pm 24$	Straight connector 8 pin	NCS165-6	1SBT200606R0001
6000	165	± 20	-	$\pm 15 \dots \pm 24$	Shielded cable 6 wires (2 m)	NCS165-6AF	1SBT200606R0002
6000	165	-	± 10	$\pm 15 \dots \pm 24$	Shielded cable 6 wires (2 m)	NCS165-6VF	1SBT200606R0102
10000	125	± 20	± 10	$\pm 15 \dots \pm 24$	Straight connector 8 pin	NCS125-10	1SBT200210R0001
10000	125	± 20	-	$\pm 15 \dots \pm 24$	Shielded cable 6 wires (2 m)	NCS125-10AF	1SBT200210R0002
10000	125	-	± 10	$\pm 15 \dots \pm 24$	Shielded cable 6 wires (2 m)	NCS125-10VF	1SBT200210R0102
10000	165	± 20	± 10	$\pm 15 \dots \pm 24$	Straight connector 8 pin	NCS165-10	1SBT200610R0001
10000	165	± 20	-	$\pm 15 \dots \pm 24$	Shielded cable 6 wires (2 m)	NCS165-10AF	1SBT200610R0002
10000	165	-	± 10	$\pm 15 \dots \pm 24$	Shielded cable 6 wires (2 m)	NCS165-10VF	1SBT200610R0102
20000	165	± 20	± 10	$\pm 15 \dots \pm 24$	Straight connector 8 pin	NCS165-20	1SBT200620R0001
20000	165	± 20	-	$\pm 15 \dots \pm 24$	Shielded cable 6 wires (2 m)	NCS165-20AF	1SBT200620R0002
20000	165	-	± 10	$\pm 15 \dots \pm 24$	Shielded cable 6 wires (2 m)	NCS165-20VF	1SBT200620R0102

NCS305 industry current sensors

6000 to 40000 A - Electronic technology

Frame mounting

These sensors are designed to be fixed by the case.
 They may be either vertically or horizontally mounted.
 The secondary connection is made with a connector or cable.
 For NCS sensors the primary conductor may be a cable, one or several bars.



NCS305-6 to NCS305-20



NCS305-6AF to NCS305-20AF
 NCS305-6VF to NCS305-20VF

Ordering details

Nominal primary current A	Opening for the primary conductor mm	Secondary current I_{S1} at $\pm I_{PN}$ mA	Secondary voltage V_{S1} at $\pm I_{PN}$ V	Supply voltage VDC	Secondary connection	Type	Order code
6000	302	± 20	± 10	+15 ... +24 ($\pm 2\%$)	Straight connector 8 pin	NCS305-6	1SBT200306R0001
6000	302	± 20	-	+15 ... +24 ($\pm 2\%$)	Shielded cable 6 wires (2 m)	NCS305-6AF	1SBT200306R0002
6000	302	-	± 10	+15 ... +24 ($\pm 2\%$)	Shielded cable 6 wires (2 m)	NCS305-6VF	1SBT200306R0102
10000	302	± 20	± 10	+15 ... +24 ($\pm 2\%$)	Straight connector 8 pin	NCS305-10	1SBT200310R0001
10000	302	± 20	-	+15 ... +24 ($\pm 2\%$)	Shielded cable 6 wires (2 m)	NCS305-10AF	1SBT200310R0002
10000	302	-	± 10	+15 ... +24 ($\pm 2\%$)	Shielded cable 6 wires (2 m)	NCS305-10VF	1SBT200310R0102
20000	302	± 20	± 10	+15 ... +24 ($\pm 2\%$)	Straight connector 8 pin	NCS305-20	1SBT200320R0001
20000	302	± 20	-	+15 ... +24 ($\pm 2\%$)	Shielded cable 6 wires (2 m)	NCS305-20AF	1SBT200320R0002
20000	302	-	± 10	+15 ... +24 ($\pm 2\%$)	Shielded cable 6 wires (2 m)	NCS305-20VF	1SBT200320R0102

NCS125 industry current sensors

Technical data

2

Utilisation

Sensors to measure DC, AC or pulsating currents with a galvanic insulation between primary and secondary circuits.



			8 pin connector	NCS125-4	-	-
			Output current shielded cable	-	NCS125-4AF	-
			Output voltage shielded cable	-	-	NCS125-4VF
Nominal primary current		A	4000	4000	4000	4000
Measuring range		A	20000	20000	20000	20000
Not measured overload	1 s/h	A peak	80000	80000	80000	80000
Secondary current I_{S1} at I_{PN}		mA	± 20	± 20	± 20	-
Secondary current I_{S2} at I_{PMAX}		mA	± 20	± 20	-	-
Residual current I_{S10}	@ +25 °C	μA	$\leq \pm 250$	$\leq \pm 250$	-	-
Residual current I_{S20}	@ +25 °C	μA	$\leq \pm 180$	$\leq \pm 180$	-	-
Thermal drift coefficient (outputs I_{S1} , I_{S2})		$\mu A/^\circ C$	$\leq \pm 4$	$\leq \pm 4$	-	-
Measuring resistance (outputs I_{S1} , I_{S2})		Ω	0 ... 350	0 ... 350	-	-
Secondary voltage V_{S1} at I_{PN}		V	± 10	-	-	± 10
Secondary voltage V_{S2} at I_{PMAX}		V	± 10	-	-	± 10
Residual voltage V_{S10}	@ +25 °C	mV	$\leq \pm 100$	-	-	$\leq \pm 100$
Residual voltage V_{S20}	@ +25 °C	mV	$\leq \pm 50$	-	-	$\leq \pm 50$
Thermal drift coefficient (outputs V_{S1} , V_{S2})		mV/°C	$\leq \pm 2$	-	-	$\leq \pm 2$
Measuring resistance (outputs V_{S1} , V_{S2})		Ω	10000 ... ∞	-	-	10000 ... ∞
Rms accuracy 50 Hz (without offset) (1) at I_{PN}	@ +25 °C	%	$\leq \pm 1$	$\leq \pm 1$	-	$\leq \pm 1$
Rms accuracy 50 Hz (without offset) (1) at I_{PMAX}	@ +25 °C	%	$\leq \pm 3$	$\leq \pm 3$	-	$\leq \pm 3$
Gain thermal drift	-25 ... +85 °C	%/°C	≤ 0.03	≤ 0.03	-	≤ 0.03
Gain thermal drift	-40 ... -25 °C	%/°C	≤ 0.1	≤ 0.1	-	≤ 0.1
Linearity (typical)		%	± 0.5	± 0.5	-	± 0.5
Delay time (typical)		μs	≤ 3	≤ 3	-	≤ 3
di/dt correctly followed		A / μs	≤ 100	≤ 100	-	≤ 100
Bandwidth	@ -1 dB	kHz	0 ... 10	0 ... 10	-	0 ... 10
No load consumption current (I_{A0+})	@ -40 °C	mA	≤ 180	≤ 180	-	≤ 180
No load consumption current (I_{A0-})		mA	≤ 35	≤ 35	-	≤ 35
Dielectric strength Primary/Secondary	50 Hz, 1 min	kV r.m.s.	5	5	-	5
Supply voltage	$\pm 2\%$	V DC	$\pm 15 ... \pm 24$	$\pm 15 ... \pm 24$	-	$\pm 15 ... \pm 24$
Mass		kg	1.1	1.4	-	1.4
Operating temperature		°C	-40 ... +85	-40 ... +85	-	-40 ... +85
Storage/startup temperature		°C	-50 ... +90	-50 ... +90	-	-50 ... +90

(1) Maximum current I_{PN} generated: 5000 A r.m.s.

General data

- Plastic case and insulating resin are self-extinguishing.
- Two fixing modes:
 - Horizontal or vertical with fixing holes in the case moulding.
 - By bar using the intermediate side plate kit (Refer to accessories and options on the following page).
- Max tightening torque for M6 screws (side plate mounting): 2 N.m
- **Direction of the current:**
 - Output current (I_{S1} and I_{S2}): A primary current flowing in the direction of the arrow results in a positive secondary output current on terminals I_{S1} and I_{S2} .
 - Output voltage (V_{S1} and V_{S2}): A primary current flowing in the direction of the arrow results in a positive secondary output voltage on terminals V_{S1} and V_{S2} .
- Burn-in test in accordance with FPTC 404304 cycle.

Primary connection

- Hole for primary conductor.
- The temperature of the primary conductor in contact with the case must not exceed 100 °C.

Secondary connection

- Male straight 8 pin connector (integrated in the sensor)
- A female straight 8 pin connector is provided as standard with each product.
- Shielded cable 6 x 2000 mm (cross section 0.5 mm²).



			NCS125-6	-	-	NCS125-10	-	-
	8 pin connector		-	NCS125-6AF	-	-	NCS125-10AF	-
	Output current shielded cable		-	-	NCS125-6VF	-	-	NCS125-10VF
	Output voltage shielded cable		-	-	-	-	-	-
Nominal primary current		A	6000	6000	6000	10000	10000	10000
Measuring range		A	30000	30000	30000	30000	30000	30000
Not measured overload	1 s/h	A peak	120000	120000	120000	200000	200000	200000
Secondary current I _{S1} at I _{PN}		mA	±20	±20	-	±20	±20	-
Secondary current I _{S2} at I _{PMAX}		mA	±20	±20	-	±20	±20	-
Residual current I _{S10}	@ +25 °C	µA	≤±250	≤±250	-	≤±250	≤±250	-
Residual current I _{S20}	@ +25 °C	µA	≤±180	≤±180	-	≤±180	≤±180	-
Thermal drift coefficient (outputs I _{S1} , I _{S2})		µA/°C	≤±4	≤±4	-	≤±4	≤±4	-
Measuring resistance (outputs I _{S1} , I _{S2})		Ω	0 ... 350	0 ... 350	-	0 ... 350	0 ... 350	-
Secondary voltage V _{S1} at I _{PN}		V	±10	-	±10	±10	-	±10
Secondary voltage V _{S2} at I _{PMAX}		V	±10	-	±10	±10	-	±10
Residual voltage V _{S10}	@ +25 °C	mV	≤±100	-	≤±100	≤±100	-	≤±100
Residual voltage V _{S20}	@ +25 °C	mV	≤±50	-	≤±50	≤±50	-	≤±50
Thermal drift coefficient (outputs V _{S1} , V _{S2})		mV/°C	≤±2	-	≤±2	≤±2	-	≤±2
Measuring resistance (outputs V _{S1} , V _{S2})		Ω	10000 ... ∞	-	10000 ... ∞	10000 ... ∞	-	10000 ... ∞
Rms accuracy 50 Hz (without offset) (1) at I _{PN}	@ +25 °C	%	≤±1	≤±1	≤±1	≤±1	≤±1	≤±1
Rms accuracy 50 Hz (without offset) (1) at I _{PMAX}	@ +25 °C	%	≤±3	≤±3	≤±3	≤±3	≤±3	≤±3
Gain thermal drift	-25 ... +85 °C	%/°C	≤0.03	≤0.03	≤0.03	≤0.03	≤0.03	≤0.03
Gain thermal drift	-40 ... -25 °C	%/°C	≤0.1	≤0.1	≤0.1	≤0.1	≤0.1	≤0.1
Linearity (typical)		%	±0.5	±0.5	±0.5	±0.5	±0.5	±0.5
Delay time (typical)		µs	≤3	≤3	≤3	≤3	≤3	≤3
di/dt correctly followed		A / µs	≤100	≤100	≤100	≤100	≤100	≤100
Bandwidth	@ -1 dB	kHz	0 ... 10	0 ... 10	0 ... 10	0 ... 10	0 ... 10	0 ... 10
No load consumption current (I _{A0+})	@ -40 °C	mA	≤180	≤180	≤180	≤180	≤180	≤180
No load consumption current (I _{A0-})		mA	≤35	≤35	≤35	≤35	≤35	≤35
Dielectric strength Primary/Secondary	50 Hz, 1 min	kV r.m.s.	5	5	5	5	5	5
Supply voltage	± 2%	VDC	±15 ... ±24	±15 ... ±24	±15 ... ±24	±15 ... ±24	±15 ... ±24	±15 ... ±24
Mass		kg	1.1	1.4	1.4	1.1	1.4	1.4
Operating temperature		°C	-40 ... +85	-40 ... +85	-40 ... +85	-40 ... +85	-40 ... +85	-40 ... +85
Storage/startup temperature		°C	-50 ... +90	-50 ... +90	-50 ... +90	-50 ... +90	-50 ... +90	-50 ... +90

(1) Maximum current I_{PN} generated: 5000 A r.m.s.

Accessories and options

PETERCEM female straight 8 pin connector

PETERCEM order code: **1SBT200000R2003** including 10 lockable connectors

Side plates (or right angle brackets)

For installation of the side plates, please refer to the mounting instructions ref. **1SBC146005M1701-1** (NCS125) or the mounting instructions ref. **1SBC146004M1701-1** (NCS165)

Side plate kit NCS125:

PETERCEM order code: **1SBT200000R2002**

Conformity

EN 50178

EN 61000-6-2, EN 61000-6-4



RoHS

NCS165 industry current sensors

Technical data

2

Utilisation

Sensors to measure DC, AC or pulsating currents with a galvanic insulation between primary and secondary circuits.

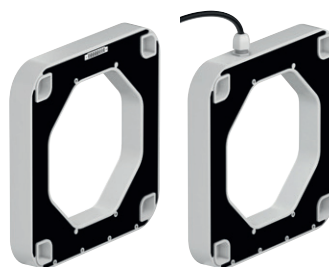

			8 pin connector	NCS165-4	-	-	NCS165-6	-	-
			Output current shielded cable	-	NCS165-4AF	-	-	NCS165-6AF	-
			Output voltage shielded cable	-	-	NCS165-4VF	-	-	NCS165-6VF
Nominal primary current		A		4000	4000	4000	6000	6000	6000
Measuring range		A		20000	20000	20000	30000	30000	30000
Not measured overload	1 s/h	A peak		80000	80000	80000	120000	120000	120000
Secondary current I_{S1} at I_{PN}		mA		±20	±20	-	±20	±20	-
Secondary current I_{S2} at $I_{P_{MAX}}$		mA		±20	±20	-	±20	±20	-
Residual current I_{S10}	@ +25 °C	µA		≤±250	≤±250	-	≤±250	≤±250	-
Residual current I_{S20}	@ +25 °C	µA		≤±180	≤±180	-	≤±180	≤±180	-
Thermal drift coefficient (outputs I_{S1} , I_{S2})		µA/°C		≤±4	≤±4	-	≤±4	≤±4	-
Measuring resistance (outputs I_{S1} , I_{S2})		Ω		0 ... 350	0 ... 350	-	0 ... 350	0 ... 350	-
Secondary voltage V_{S1} at I_{PN}		V		±10	-	±10	±10	-	±10
Secondary voltage V_{S2} at $I_{P_{MAX}}$		V		±10	-	±10	±10	-	±10
Residual voltage V_{S10}	@ +25 °C	mV		≤±100	-	≤±100	≤±100	-	≤±100
Residual voltage V_{S20}	@ +25 °C	mV		≤±50	-	≤±50	≤±50	-	≤±50
Thermal drift coefficient (outputs V_{S1} , V_{S2})		mV/°C		≤±2	-	≤±2	≤±2	-	≤±2
Measuring resistance (outputs V_{S1} , V_{S2})		Ω		10000 ... ∞	-	10000 ... ∞	10000 ... ∞	-	10000 ... ∞
Rms accuracy 50 Hz (without offset) (1) at I_{PN}	@ +25 °C	%		≤±1	≤±1	≤±1	≤±1	≤±1	≤±1
Rms accuracy 50 Hz (without offset) (1) at $I_{P_{MAX}}$	@ +25 °C	%		≤±3	≤±3	≤±3	≤±3	≤±3	≤±3
Gain thermal drift	-25 ... +85 °C	%/°C		≤0.03	≤0.03	≤0.03	≤0.03	≤0.03	≤0.03
Gain thermal drift	-40 ... -25 °C	%/°C		≤0.1	≤0.1	≤0.1	≤0.1	≤0.1	≤0.1
Linearity (typical)		%		±0.5	±0.5	±0.5	±0.5	±0.5	±0.5
Delay time (typical)		µs		≤3	≤3	≤3	≤3	≤3	≤3
di/dt correctly followed		A / µs		≤100	≤100	≤100	≤100	≤100	≤100
Bandwidth	@ -1 dB	kHz		0 ... 10	0 ... 10	0 ... 10	0 ... 10	0 ... 10	0 ... 10
No load consumption current (I_{A0+})	@ -40 °C	mA		≤210	≤210	≤210	≤210	≤210	≤210
No load consumption current (I_{A0-})		mA		≤35	≤35	≤35	≤35	≤35	≤35
Dielectric strength Primary/Secondary	50 Hz, 1 min	kV r.m.s.		5	5	5	5	5	5
Supply voltage	± 2%	V DC		±15 ... ±24	±15 ... ±24	±15 ... ±24	±15 ... ±24	±15 ... ±24	±15 ... ±24
Mass		kg		1.4	1.7	1.7	1.4	1.7	1.7
Operating temperature		°C		-40 ... +85	-40 ... +85	-40 ... +85	-40 ... +85	-40 ... +85	-40 ... +85
Storage/startup temperature		°C		-50 ... +90	-50 ... +90	-50 ... +90	-50 ... +90	-50 ... +90	-50 ... +90

(1) Maximum current I generated: 5000 A r.m.s.

General data

- Plastic case and insulating resin are self-extinguishing
- Two fixing modes:
 - Horizontal or vertical with fixing holes in the case moulding.
 - By bar using the intermediate side plate kit (Refer to Accessories and options on the following page).
- Max tightening torque for M6 screws (side plate mounting): 2 N.m
- **Direction of the current:**
 - Output current (I_{S1} and I_{S2}): A primary current flowing in the direction of the arrow results in a positive secondary output current on terminals I_{S1} and I_{S2} .
 - Output voltage (V_{S1} and V_{S2}): A primary current flowing in the direction of the arrow results in a positive secondary output voltage on terminals V_{S1} and V_{S2} .
- Burn-in test in accordance with FPTC 404304 cycle

Primary connection

- Hole for primary conductor.
- The temperature of the primary conductor in contact with the case must not exceed 100 °C.

Secondary connection

- Male straight 8 pin connector (integrated in the sensor)
- A female straight 8 pin connector is provided as standard with each product
- Shielded cable 6 x 2000 mm (cross section 0.5 mm²).

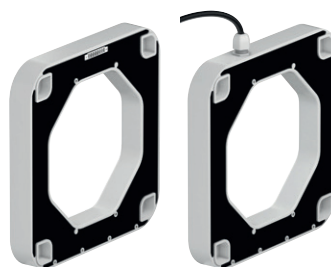

	8 pin connector	NCS165-10	-	-	NCS165-20	-	-
Output current shielded cable	-	-	NCS165-10AF	-	-	NCS165-20AF	-
Output voltage shielded cable	-	-	-	NCS165-10VF	-	-	NCS165-20VF
Nominal primary current		A	10000	10000	10000	20000	20000
Measuring range		A	30000	30000	30000	40000	40000
Not measured overload	1 s/h	A peak	200000	200000	200000	200000	200000
Secondary current I _{S1} at I _{PN}		mA	±20	±20	-	±20	-
Secondary current I _{S2} at I _{PMAX}		mA	±20	±20	-	±20	-
Residual current I _{S10}	@ +25 °C	µA	≤±250	≤±250	-	≤±250	≤±250
Residual current I _{S20}	@ +25 °C	µA	≤±180	≤±180	-	≤±180	≤±180
Thermal drift coefficient (outputs I _{S1} , I _{S2})		µA/°C	≤±4	≤±4	-	≤±4	≤±4
Measuring resistance (outputs I _{S1} , I _{S2})		Ω	0 ... 350	0 ... 350	-	0 ... 350	0 ... 350
Secondary voltage V _{S1} at I _{PN}		V	±10	-	±10	±10	-
Secondary voltage V _{S2} at I _{PMAX}		V	±10	-	±10	±10	-
Residual voltage V _{S10}	@ +25 °C	mV	≤±100	-	≤±100	≤±100	-
Residual voltage V _{S20}	@ +25 °C	mV	≤±50	-	≤±50	≤±50	-
Thermal drift coefficient (outputs V _{S1} , V _{S2})		mV/°C	≤±2	-	≤±2	≤±2	-
Measuring resistance (outputs V _{S1} , V _{S2})		Ω	10000 ... ∞	-	10000 ... ∞	10000 ... ∞	-
Rms accuracy 50 Hz (without offset) (1) at I _{PN}	@ +25 °C	%	≤±1	≤±1	≤±1	≤±1	≤±1
Rms accuracy 50 Hz (without offset) (1) at I _{PMAX}	@ +25 °C	%	≤±3	≤±3	≤±3	≤±3	≤±3
Gain thermal drift	-25 ... +85 °C	%/°C	≤0.03	≤0.03	≤0.03	≤0.03	≤0.03
Gain thermal drift	-40 ... -25 °C	%/°C	≤0.1	≤0.1	≤0.1	≤0.1	≤0.1
Linearity (typical)		%	±0.5	±0.5	±0.5	±0.5	±0.5
Delay time (typical)		µs	≤3	≤3	≤3	≤3	≤3
di/dt correctly followed		A / µs	≤100	≤100	≤100	≤100	≤100
Bandwidth	@ -1 dB	kHz	0 ... 10	0 ... 10	0 ... 10	0 ... 10	0 ... 10
No load consumption current (I _{A0+})	@ -40 °C	mA	≤210	≤210	≤210	≤210	≤210
No load consumption current (I _{A0-})		mA	≤35	≤35	≤35	≤35	≤35
Dielectric strength Primary/Secondary	50 Hz, 1 min	kV r.m.s.	5	5	5	5	5
Supply voltage	± 2%	VDC	±15 ... ±24	±15 ... ±24	±15 ... ±24	±15 ... ±24	±15 ... ±24
Mass		kg	1.4	1.7	1.7	1.4	1.7
Operating temperature		°C	-40 ... +85	-40 ... +85	-40 ... +85	-40 ... +85	-40 ... +85
Storage/startup temperature		°C	-50 ... +90	-50 ... +90	-50 ... +90	-50 ... +90	-50 ... +90

(1) Maximum current I_{PN} generated: 5000 A r.m.s.

Accessories and options

PETERCEM female straight 8 pin connector

PETERCEM order code : **1SBT200000R2003** includes 10 lockable connectors

Side plates (or right angle brackets)

For installation of the side plates, please refer to the mounting instructions ref. **1SBC146004M1701-1**

Side plate kit NCS165:

PETERCEM order code: **1SBT200000R2001**

Conformity

EN 50178

EN 61000-6-2, EN 61000-6-4



RoHS

NCS305 industry current sensors

Technical data

2

Utilisation

Sensors to measure DC, AC or pulsating currents with a galvanic insulation between primary and secondary circuits.



			8 pin connector	NCS305-6	-	-	NCS305-10
			Output current shielded cable	-	NCS305-6AF	-	-
			Output voltage shielded cable	-	-	NCS305-6VF	-
Nominal primary current		A		6000	6000	6000	10000
Measuring range		A		20000	20000	20000	30000
Not measured overload	1 s/h	A peak		80000	80000	80000	120000
Secondary current I _{S1} at I _{PN}		mA		±20	±20	-	±20
Secondary current I _{S2} at I _{PMAX}		mA		±20	±20	-	±20
Residual current I _{S10}	@ +25 °C	µA		≤ ±250	≤ ±250	-	≤ ±250
Residual current I _{S20}	@ +25 °C	µA		≤ ±180	≤ ±180	-	≤ ±180
Thermal drift coefficient (outputs I _{S1} , I _{S2})		µA/°C		≤ ±4	≤ ±4	-	≤ ±4
Measuring resistance (outputs I _{S1} , I _{S2})		Ω		0 ... 350	0 ... 350	-	0 ... 350
Secondary voltage V _{S1} at I _{PN}		V		±10	-	±10	±10
Secondary voltage V _{S2} at I _{PMAX}		V		±10	-	±10	±10
Residual voltage V _{S10}	@ +25 °C	mV		≤ ±100	-	≤ ±100	≤ ±100
Residual voltage V _{S20}	@ +25 °C	mV		≤ ±50	-	≤ ±50	≤ ±50
Thermal drift coefficient (outputs V _{S1} , V _{S2})		mV/°C		≤ ±2	-	≤ ±2	≤ ±2
Measuring resistance (outputs V _{S1} , V _{S2})		Ω		10000 ... ∞	-	10000 ... ∞	10000 ... ∞
Rms accuracy 50 Hz (without offset) (1) at I _{PN}	@ +25 °C	%		≤ ±1	≤ ±1	≤ ±1	≤ ±1
Rms accuracy 50 Hz (without offset) (1) at I _{PMAX}	@ +25 °C	%		≤ ±3	≤ ±3	≤ ±3	≤ ±3
Gain thermal drift	-20 ... +85 °C	%/°C		≤ ±0.01	≤ ±0.01	≤ ±0.01	≤ ±0.01
Gain thermal drift	-40 ... -20 °C	%/°C		≤ ±0.04	≤ ±0.04	≤ ±0.04	≤ ±0.04
Linearity (typical)		%		±0.5	±0.5	±0.5	±0.5
Delay time (typical)		µs		≤ 10	≤ 10	≤ 10	≤ 10
di/dt correctly followed		A / µs		≤ 100	≤ 100	≤ 100	≤ 100
Bandwidth	@ -1 dB	kHz		0 ... 10	0 ... 10	0 ... 10	0 ... 10
No load consumption current (I _{A0+})	@ -40 °C	mA		≤ 300	≤ 300	≤ 300	≤ 300
Dielectric strength Primary/Secondary	50 Hz, 1 min	kV r.m.s.		5	5	5	5
Supply voltage	± 2%	V DC		+15 ... +24	+15 ... +24	+15 ... +24	+15 ... +24
Mass		kg		5.5	5.8	5.8	5.5
Operating temperature		°C		-40 ... +85	-40 ... +85	-40 ... +85	-40 ... +85
Storage/startup temperature		°C		-50 ... +90	-50 ... +90	-50 ... +90	-50 ... +90

(1) Maximum current I_{PN} generated: 5000 A r.m.s.

General data

- Plastic case and insulating resin are self-extinguishing.
- Clip on mounting mode
- Two fixing modes:
 - Horizontal with fixing holes in the case moulding.
 - By bar using the intermediate side plate kit (Refer to accessories and options on the following page).
- Max tightening torque for M6.3 screws (side plate mounting): 4.5 N.m
- Direction of the current:
 - Output current (IS1 and IS2): A primary current flowing in the direction of the arrow results in a positive secondary output current on terminals IS1 and IS2.
 - Output voltage (VS1 and VS2): A primary current flowing in the direction of the arrow results in a positive secondary output voltage on terminals VS1 and VS2.
- Burn-in test in accordance with FPTC 404304 cycle.

Primary connection

- Hole for primary conductor.
- The temperature of the primary conductor in contact with the case must not exceed 100 °C.

Secondary connection

- Male straight 8 pin connector (integrated in the sensor)
- A female straight 8 pin connector is provided as standard with each product.
- Shielded cable 6 x 2000 mm (cross section 0.5 mm²).

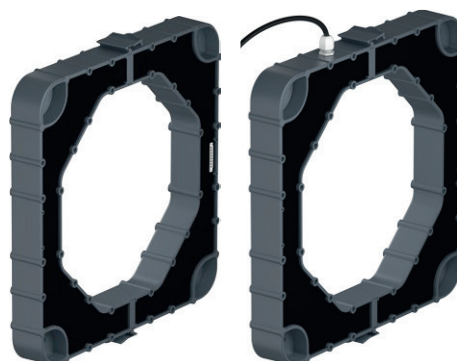

			8 pin connector	-	-	NCS305-20	-	-
			Output current shielded cable	NCS305-10AF	-	-	NCS305-20AF	-
			Output voltage shielded cable	-	NCS305-10VF	-	-	NCS305-20VF
Nominal primary current		A	10000	10000	20000	20000	20000	20000
Measuring range		A	30000	30000	40000	40000	40000	40000
Not measured overload	1 s/h	A peak	120000	120000	200000	200000	200000	200000
Secondary current I _{S1} at I _{PN}		mA	±20	-	±20	±20	-	-
Secondary current I _{S2} at I _{PMAX}		mA	±20	-	±20	±20	-	-
Residual current I _{S10}	@ +25 °C	µA	≤ ±250	-	≤ ±250	≤ ±250	-	-
Residual current I _{S20}	@ +25 °C	µA	≤ ±180	-	≤ ±180	≤ ±180	-	-
Thermal drift coefficient (outputs I _{S1} , I _{S2})		µA/°C	≤ ±4	-	≤ ±4	≤ ±4	-	-
Measuring resistance (outputs I _{S1} , I _{S2})		Ω	0 ... 350	-	0 ... 350	0 ... 350	-	-
Secondary voltage V _{S1} at I _{PN}		V	-	±10	±10	-	±10	-
Secondary voltage V _{S2} at I _{PMAX}		V	-	±10	±10	-	±10	-
Residual voltage V _{S10}	@ +25 °C	mV	-	≤ ±100	≤ ±100	-	≤ ±100	-
Residual voltage V _{S20}	@ +25 °C	mV	-	≤ ±50	≤ ±50	-	≤ ±50	-
Thermal drift coefficient (outputs V _{S1} , V _{S2})		mV/°C	-	≤ ±2	≤ ±2	-	≤ ±2	-
Measuring resistance (outputs V _{S1} , V _{S2})		Ω	-	10000 ... ∞	10000 ... ∞	-	10000 ... ∞	-
Rms accuracy 50 Hz (without offset) (1) at I _{PN}	@ +25 °C	%	≤ ±1	≤ ±1	≤ ±1	≤ ±1	≤ ±1	≤ ±1
Rms accuracy 50 Hz (without offset) (1) at I _{PMAX}	@ +25 °C	%	≤ ±3	≤ ±3	≤ ±3	≤ ±3	≤ ±3	≤ ±3
Gain thermal drift	-20 ... +85 °C	%/°C	≤ ±0.01	≤ ±0.01	≤ ±0.01	≤ ±0.01	≤ ±0.01	≤ ±0.01
Gain thermal drift	-40 ... -20 °C	%/°C	≤ ±0.04	≤ ±0.04	≤ ±0.04	≤ ±0.04	≤ ±0.04	≤ ±0.04
Linearity (typical)		%	±0.5	±0.5	±0.5	±0.5	±0.5	±0.5
Delay time (typical)		µs	≤ 10	≤ 10	≤ 10	≤ 10	≤ 10	≤ 10
di/dt correctly followed		A / µs	≤ 100	≤ 100	≤ 100	≤ 100	≤ 100	≤ 100
Bandwidth	@ -1 dB	kHz	0 ... 10	0 ... 10	0 ... 10	0 ... 10	0 ... 10	0 ... 10
No load consumption current (I _{A0+})	@ -40 °C	mA	≤ 300	≤ 300	≤ 300	≤ 300	≤ 300	≤ 300
Dielectric strength Primary/Secondary	50 Hz, 1 min	kV r.m.s.	5	5	5	5	5	5
Supply voltage	± 2%	VDC	+15 ... +24	+15 ... +24	+15 ... +24	+15 ... +24	+15 ... +24	+15 ... +24
Mass		kg	5.8	5.8	5.5	5.8	5.8	5.8
Operating temperature		°C	-40 ... +85	-40 ... +85	-40 ... +85	-40 ... +85	-40 ... +85	-40 ... +85
Storage/startup temperature		°C	-50 ... +90	-50 ... +90	-50 ... +90	-50 ... +90	-50 ... +90	-50 ... +90

(1) Maximum current I_{PN} generated: 5000 A r.m.s.

Accessories and options

PETERCEM female straight 8 pin connector

PETERCEM order code: **1SBT200000R2003** including 10 lockable connectors

Side plates

For installation of the side plates, please refer to the mounting instructions ref. **1SBC146011M1701**

Side plate kit NCS305:

PETERCEM order code: **1SBT200000R2005**

Conformity

EN 50178

EN 61000-6-2, EN 61000-6-4



RoHS

NCS125 industry current sensors

Dimensions (mm)

2

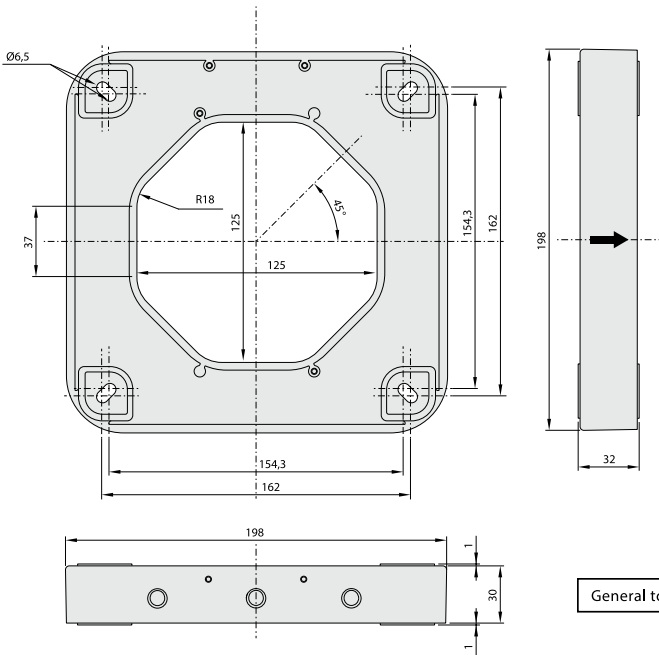

General tolerance : ±1 mm

NCS125-4 ... NCS125-10VF

Standard NCS125-4...NCS125-10 sensors secondary connections

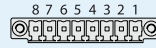

Straight connector base (with 3.81 mm pitch)
Maximum tightening torque: 0.3 N.m

Terminal identification

- 1 : +V_A (+15 ... +24 V DC)
- 2 : 0 V
- 3 : -V_A (-15 ... -24 V DC)
- 4 : V_{S1} (±10 V @ I_{PN})
- 5 : V_{S2} (±10 V @ I_{PMAX})
- 6 : I_{S1} (±20 mA @ I_{PN})
- 7 : I_{S2} (±20 mA @ I_{PMAX})
- 8 : 0 V

Shielding: see instructions for mounting and wiring

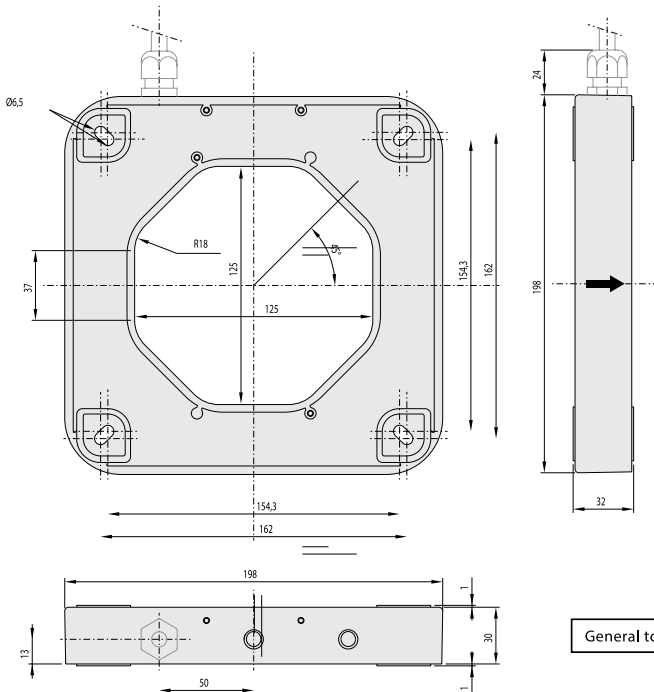

General tolerance : ±1 mm

NCS125-4AF...NCS125-10AF and
NCS125-4VF...NCS125-10VF

Standard NCS125-4AF...NCS125-10AF and NCS125-4VF...NCS125-10VF sensors secondary connections

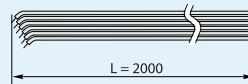

Shielded cable 6 wires with braided earth
Cross section: 0.5 mm²
Length: 2 m ±0.1

AF range wire identification

- 1 : Red: +V_A (+15 ... +24 V DC)
- 2 : Black: 0 V
- 3 : Blue: -V_A (-15 ... -24 V DC)
- 4 : NC:
- 5 : NC:
- 6 : Green: I_{S1} (±20 mA @ I_{PN})
- 7 : White: I_{S2} (±20 mA @ I_{PMAX})
- 8 : Brown: 0 V

Shielding: see instructions for mounting and wiring

VF range wire identification

- 1 : Red: +V_A (+15 ... +24 V DC)
- 2 : Black: 0 V
- 3 : Blue: -V_A (-15 ... -24 V DC)
- 4 : Green: V_{S1} (±10 V @ I_{PN})
- 5 : White: V_{S2} (±10 V @ I_{PMAX})
- 6 : NC:
- 7 : NC:
- 8 : Brown: 0 V

Shielding: see instructions for mounting and wiring

NCS125 industry current sensors

Dimensions and arrangement of right angle brackets (mm)

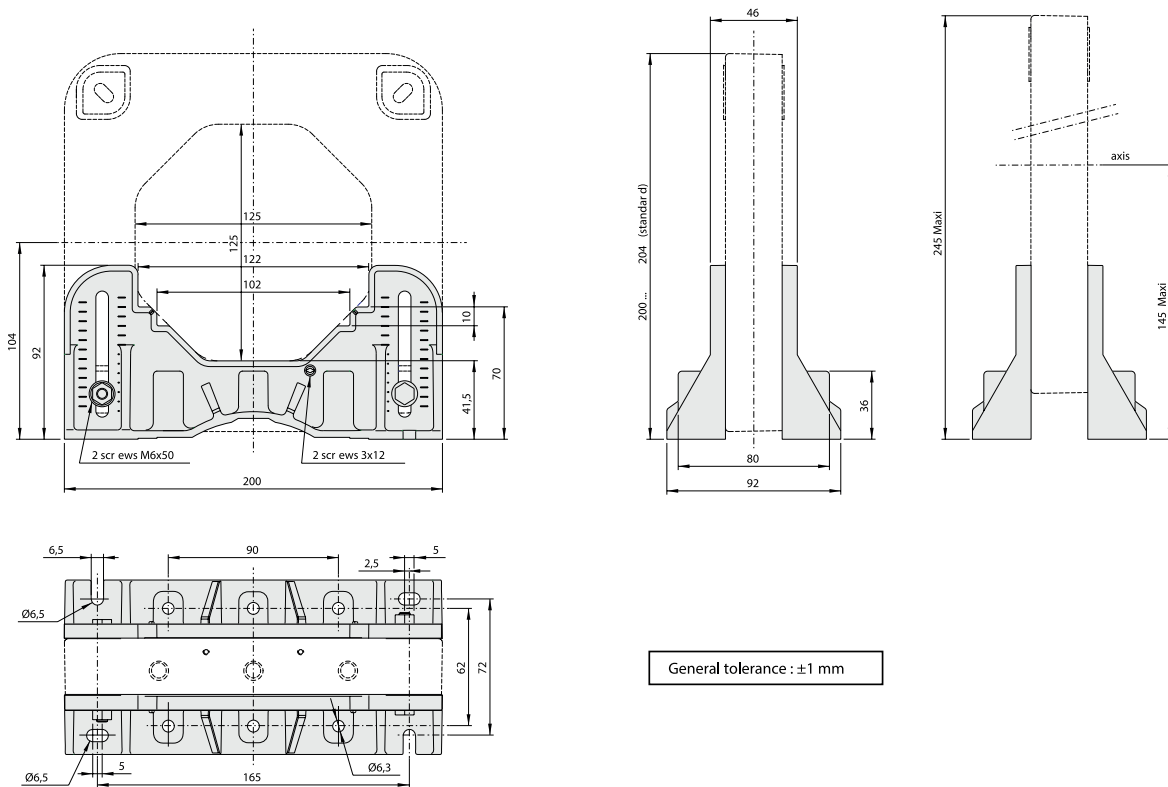

2

Right angle brackets mounting on NCS125 sensors

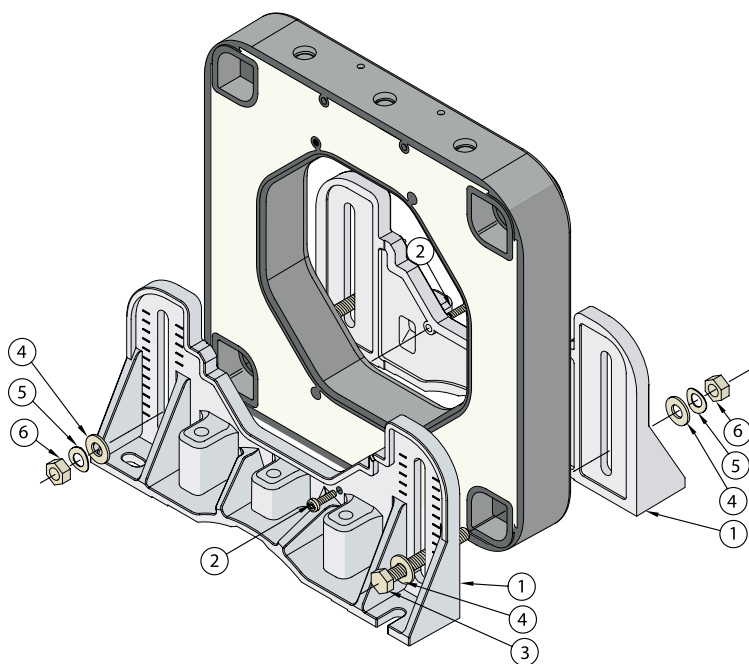

- 1 - Side plate: x2
- 2 - Standard positioning screw: x2 (3x12)
- 3 - Side plate screw M6: x2 (6x50)
- 4 - Flat washer: x4
- 5 - Spring washer: x2
- 6 - Locknut: x2
- 7 - Not used:
 - Side plate screw M6: x4 (6x30)
 - Flat washer: x4
 - Spring washer: x2
 - Locknut: x2

NCS125 industry current sensors

Dimensions and arrangement of right angle brackets (mm)

2

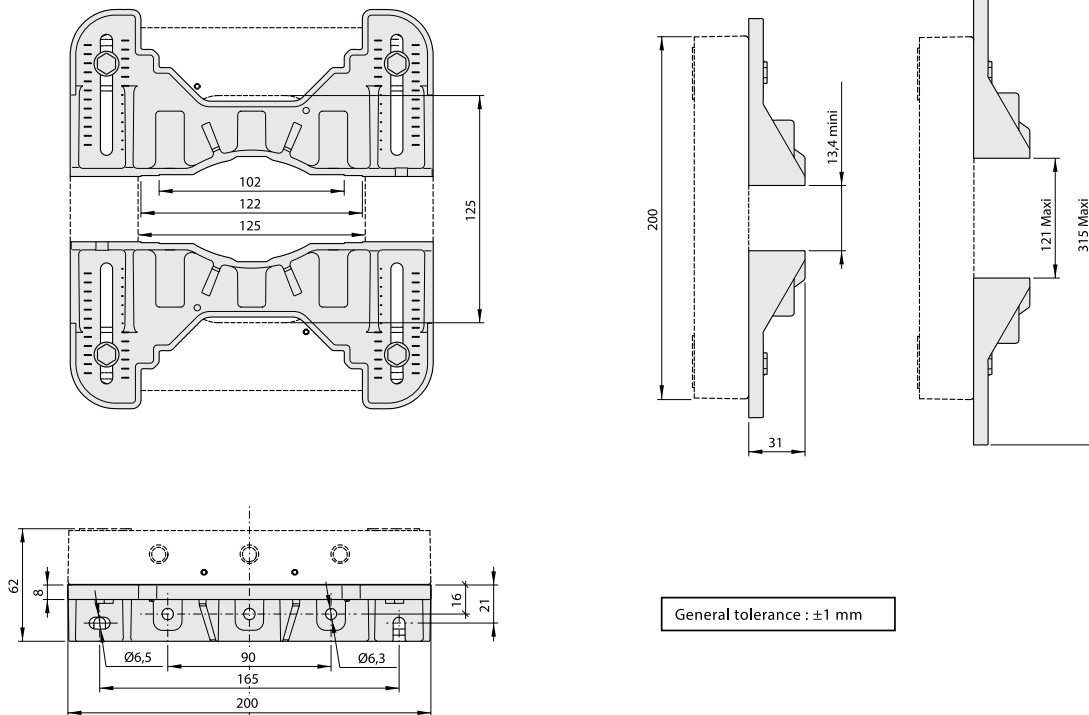

Right angle brackets mounting on NCS125 sensors

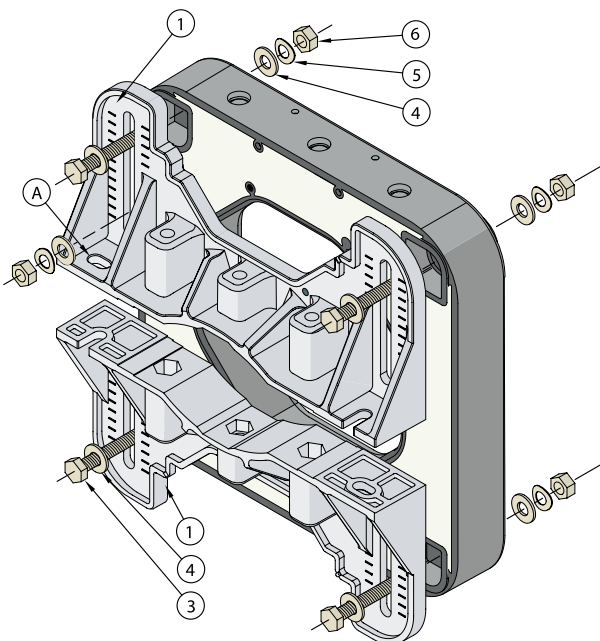

- 1 - Side plate: x2
- 3 - Side plate screw M6: x4 (6x30)
- 4 - Flat washer: x8
- 5 - Spring washer: x4
- 6 - Locknut: x4
- 7 - Not used:
 - Side plate screw M6: x2 (6x50)
 - Standard positioning screw: x2 (3x12)

A - The screws for clamping the side plates to the bar (or cable) are not supplied

NCS125 industry current sensors

Dimensions and arrangement of right angle brackets (mm)

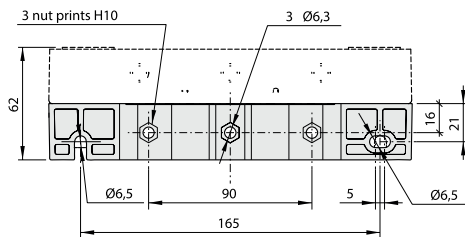
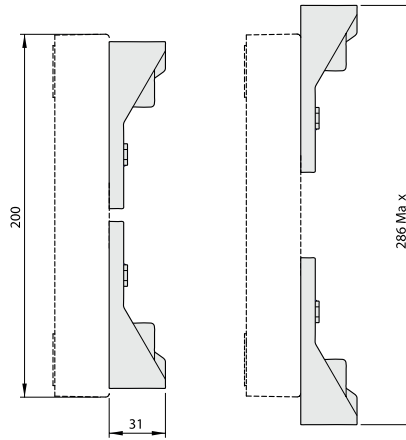
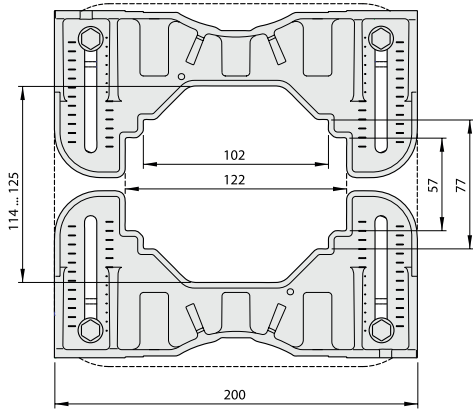

General tolerance: ± 1 mm

Right angle brackets mounting on NCS125 sensors

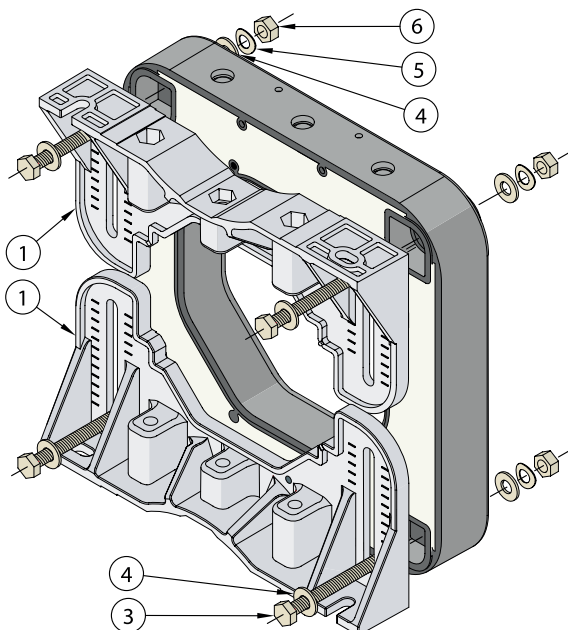

- 1 - Side plate: x2
- 3 - Side plate screw M6: x2 (6x30)
- 4 - Flat washer: x8
- 5 - Spring washer: x4
- 6 - Locknut: x4
- 7 - Not used:
 - Side plate screw M6: x4 (6x30)
 - Standard positioning screw: x2 (3x12)

NCS165 industry current sensors

Dimensions (mm)

2

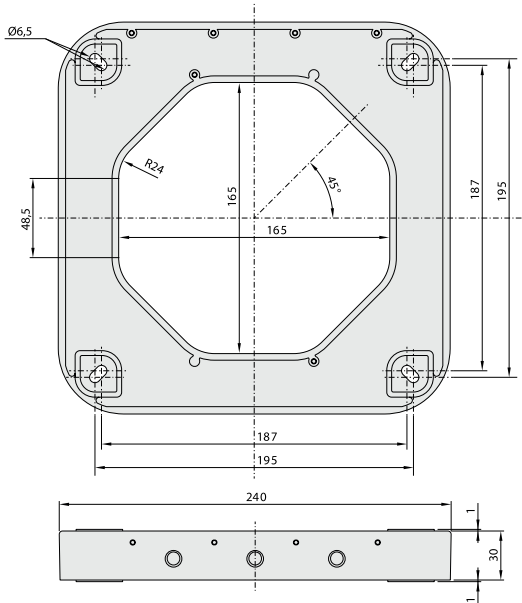

NCS165-4 ... NCS165-20

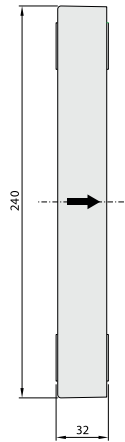

Standard NCS165-4...NCS165-20 sensors secondary connections

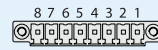

Straight connector base (with 3.81 mm pitch)
Maximum tightening torque: 0.3 N.m

Terminal identification

- 1 : +V_A (+15 ... +24 V DC)
- 2 : 0 V
- 3 : -V_A (-15 ... -24 V DC)
- 4 : V_{S1} (±10 V @ I_{PN})
- 5 : V_{S2} (±10 V @ I_{PMAX})
- 6 : I_{S1} (±20 mA @ I_{PN})
- 7 : I_{S2} (±20 mA @ I_{PMAX})
- 8 : 0 V

Shielding: see instructions for mounting and wiring

General tolerance : ±1 mm

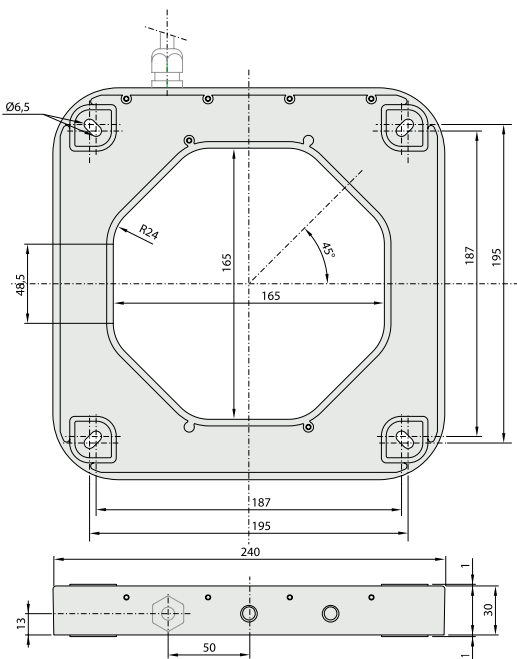

NCS165-4AF...NCS165-20AF and
NCS165-4VF...NCS165-20VF

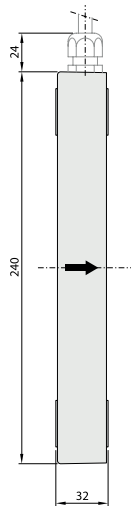

Standard NCS165-4AF...NCS165-20AF and NCS165-4VF...NCS165-20VF sensors secondary connections

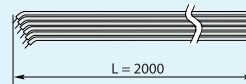

Shielded cable 6 wires with braided earth
Cross section: 0.5 mm²
Length: 2 m ±0.1

AF range wire identification

- 1 : Red: +V_A (+15 ... +24 V DC)
- 2 : Black: 0 V
- 3 : Blue: -V_A (-15 ... -24 V DC)
- 4 : NC:
- 5 : NC:
- 6 : Green: I_{S1} (±20 mA @ I_{PN})
- 7 : White: I_{S2} (±20 mA @ I_{PMAX})
- 8 : Brown: 0 V

Shielding: see instructions for mounting and wiring

VF range wire identification

- 1 : Red: +V_A (+15 ... +24 V DC)
- 2 : Black: 0 V
- 3 : Blue: -V_A (-15 ... -24 V DC)
- 4 : Green: V_{S1} (±10 V @ I_{PN})
- 5 : White: V_{S2} (±10 V @ I_{PMAX})
- 6 : NC:
- 7 : NC:
- 8 : Brown: 0 V

Shielding: see instructions for mounting and wiring

General tolerance : ±1 mm

NCS165 industry current sensors

Dimensions and arrangement of right angle brackets (mm)

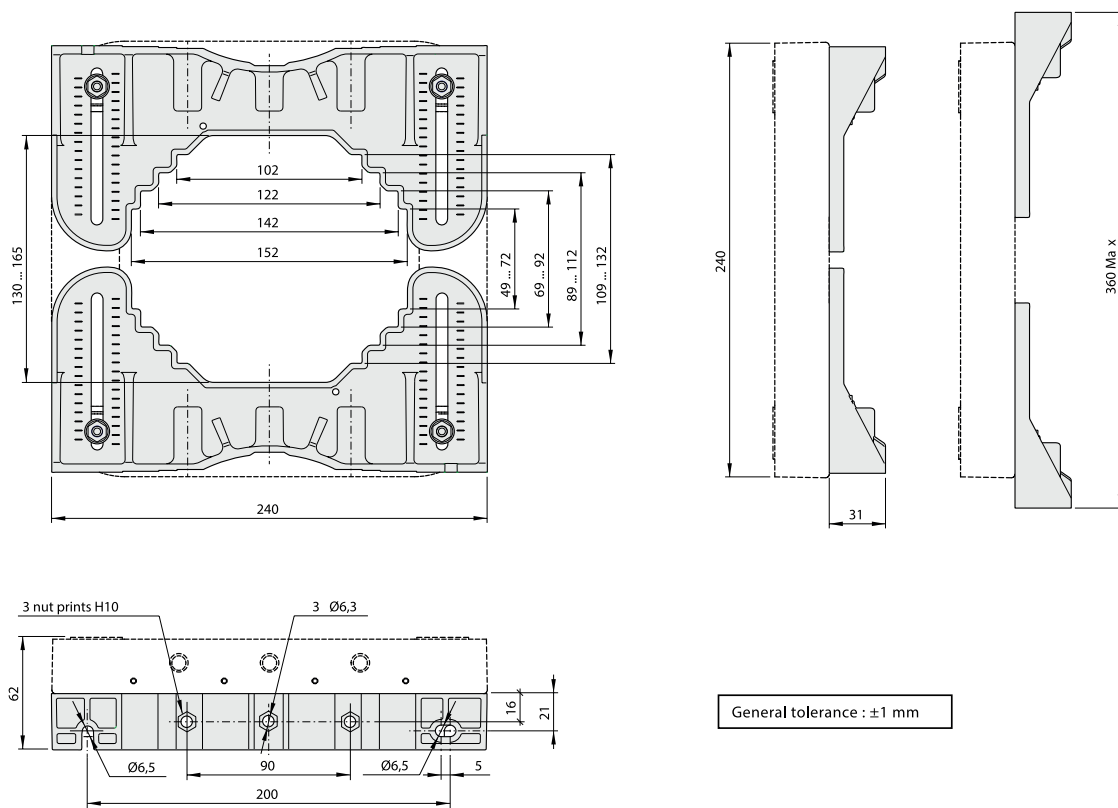

2

Right angle brackets mounting on NCS125 sensors

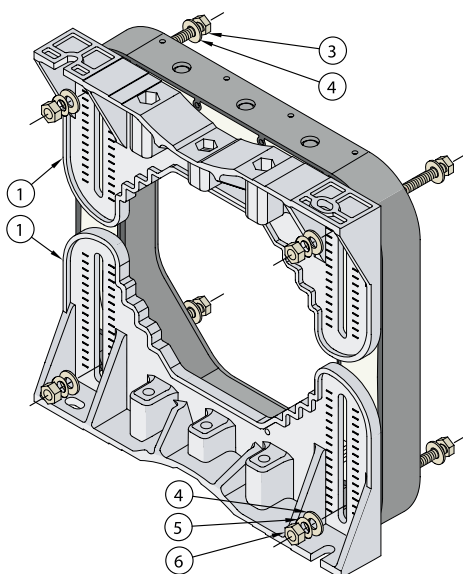

- 1 - Side plate: x2
- 3 - Side plate screw M6: x4 (6x30)
- 4 - Flat washer: x8
- 5 - Spring washer: x4
- 6 - Locknut: x4
- 7 - Not used:
 - Side plate screw M6: x2 (6x30)
 - Standard positioning screw: x2 (3x12)

NCS165 industry current sensors

Dimensions and arrangement of right angle brackets (mm)

2

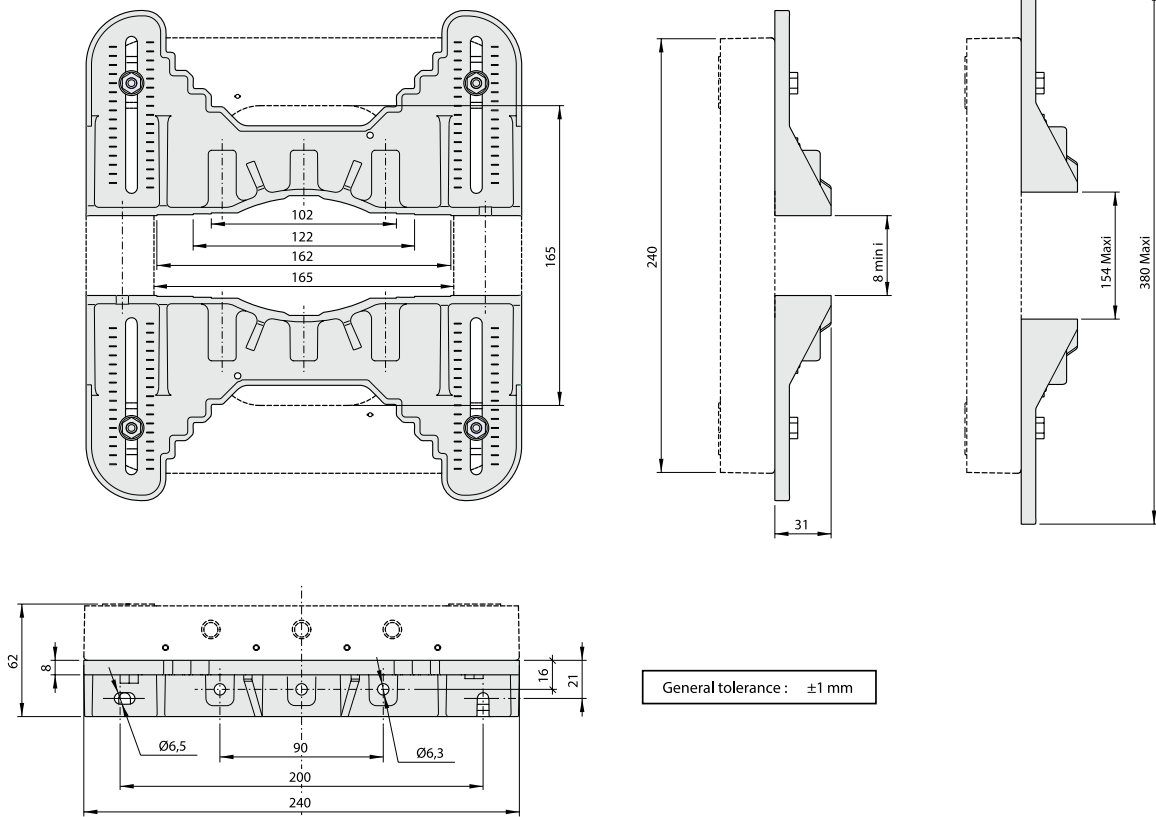

Right angle brackets mounting on NCS165 sensors

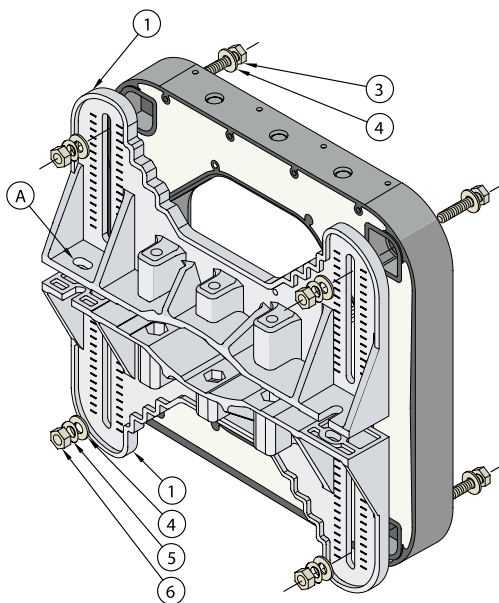

- 1 - Side plate: x2
- 3 - Side plate screw M6: x4 (6x30)
- 4 - Flat washer: x8
- 5 - Spring washer: x4
- 6 - Locknut: x4
- 7 - Not used:
 - Side plate screw M6: x2 (6x50)
 - Standard positioning screw: x2 (3x12)

A - The screws for clamping the side plates to the bar (or cable) are not supplied

NCS165 industry current sensors

Dimensions and arrangement of right angle brackets (mm)

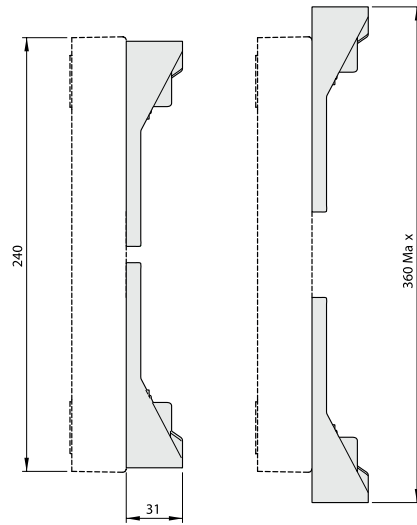
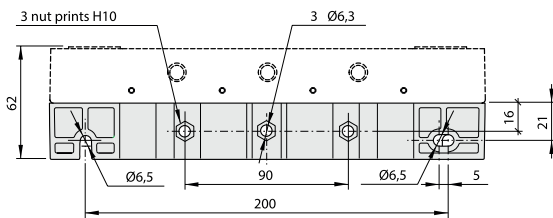
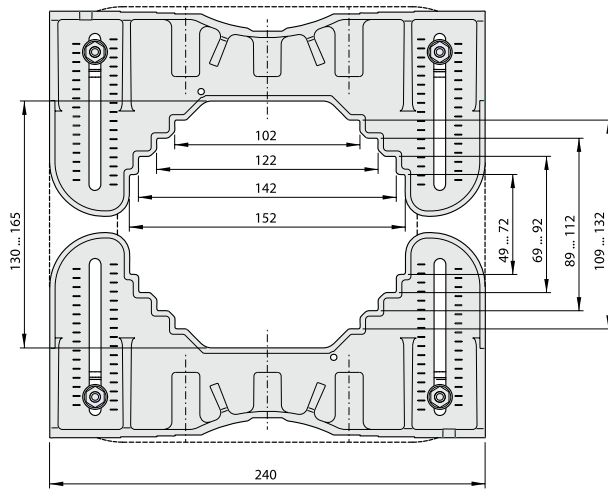

General tolerance : ± 1 mm

Right angle brackets mounting on NCS125 sensors

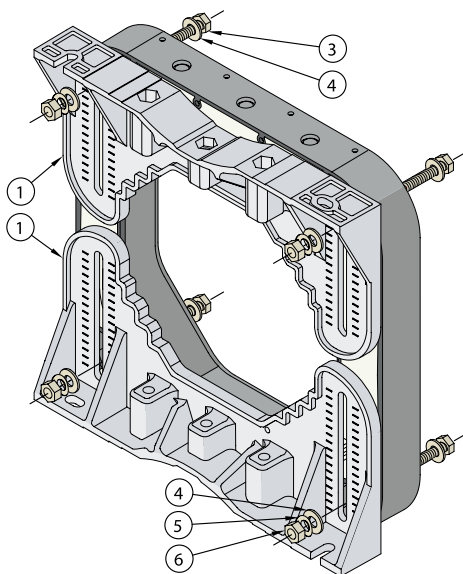

- 1 - Side plate: x2
- 3 - Side plate screw M6: x4 (6x30)
- 4 - Flat washer: x8
- 5 - Spring washer: x4
- 6 - Locknut: x4
- 7 - Not used:
 - Side plate screw M6: x2 (6x30)
 - Standard positioning screw: x2 (3x12)

NCS305 industry current sensors

Dimensions (mm)

2

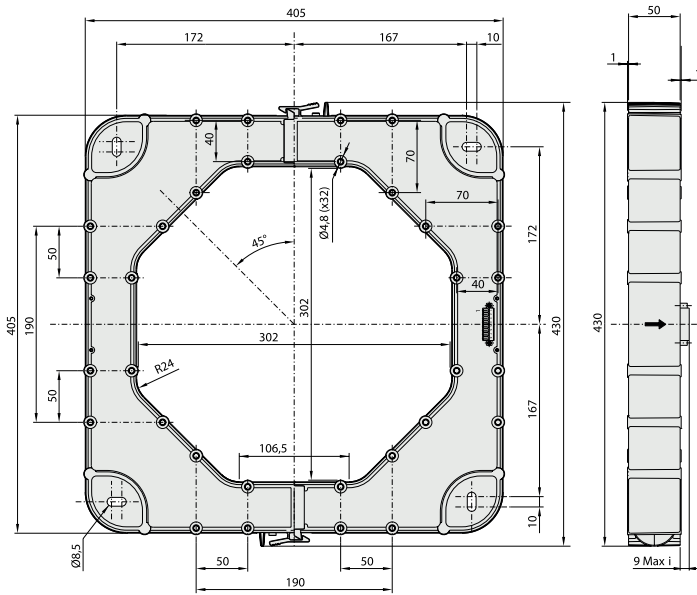

NCS305-6 ... NCS305-20

Standard NCS305-6...NCS305-20 sensors secondary connections

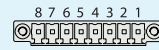

Straight connector base (with 3.81 mm pitch)
Maximum tightening torque: 0.3 N.m

Terminal identification

- 1 : +V_A (+15 ... +24 V DC)
- 2 : 0 V
- 3 : NC
- 4 : V_{S1} (±10 V @ I_{PN})
- 5 : V_{S2} (±10 V @ I_{PMAX})
- 6 : I_{S1} (±20 mA @ I_{PN})
- 7 : I_{S2} (±20 mA @ I_{PMAX})
- 8 : 0 V

Shielding: see instructions for mounting and wiring

General tolerance : ±1 mm

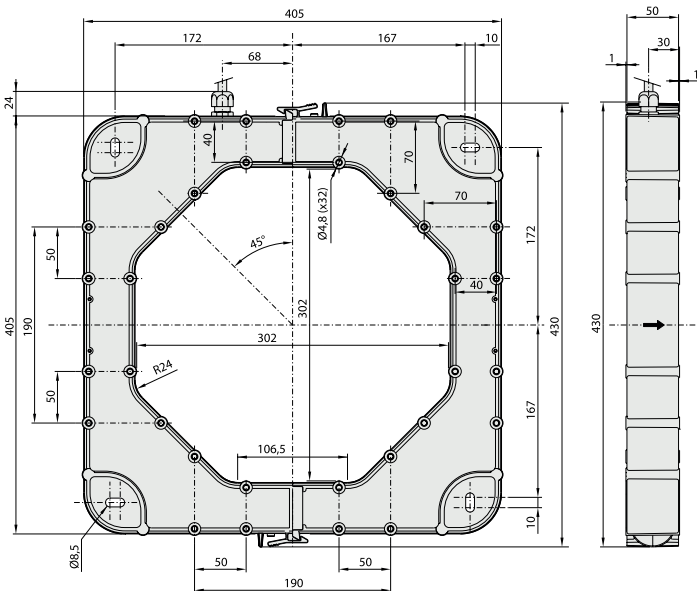

NCS305-6AF ... NCS305-20AF and
NCS305-6VF ... NCS305-20VF

Standard NCS305-6AF...NCS305-20AF and NCS305-6VF...NCS305-20VF sensors secondary connections

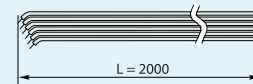

Shielded cable 6 wires with braided earth
Cross section: 0.5 mm²
Length: 2 m ±0.1

AF range wire identification

- 1 : Red: +V_A (+15 ... +24 V DC)
- 2 : Black: 0 V
- 3 : Blue: NC
- 4 : NC:
- 5 : NC:
- 6 : Green: I_{S1} (±20 mA @ I_{PN})
- 7 : White: I_{S2} (±20 mA @ I_{PMAX})
- 8 : Brown: 0 V

Shielding: see instructions for mounting and wiring

VF range wire identification

- 1 : Red: +V_A (+15 ... +24 V DC)
- 2 : Black: 0 V
- 3 : Blue: NC
- 4 : Green: V_{S1} (±10 V @ I_{PN})
- 5 : White: V_{S2} (±10 V @ I_{PMAX})
- 6 : NC:
- 7 : NC:
- 8 : Brown: 0 V

Shielding: see instructions for mounting and wiring

General tolerance : ±1 mm

NCS305 industry current sensors

Dimensions and arrangement of side plate (mm)

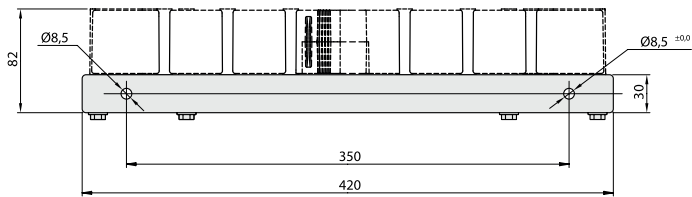
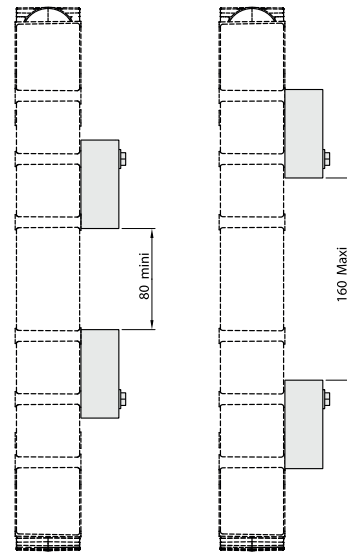
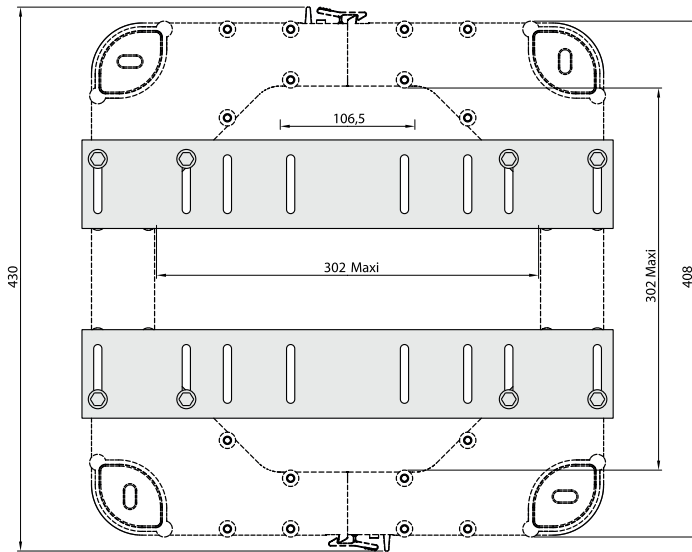

General tolerance : ±1 mm

Side plate mounting on NCS305 sensors

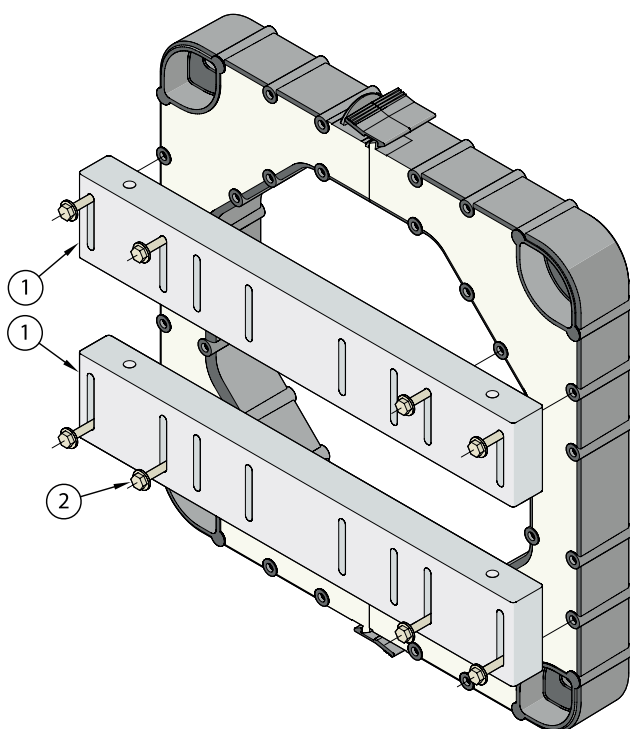

- 1 - Side plate: x2
- 2 - M6 screw: x8 (6.3x50)

NCS305 industry current sensors

Dimensions and arrangement of side plate (mm)

2

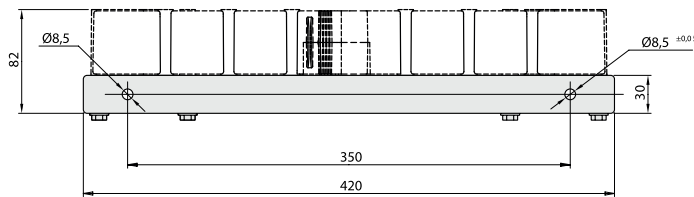
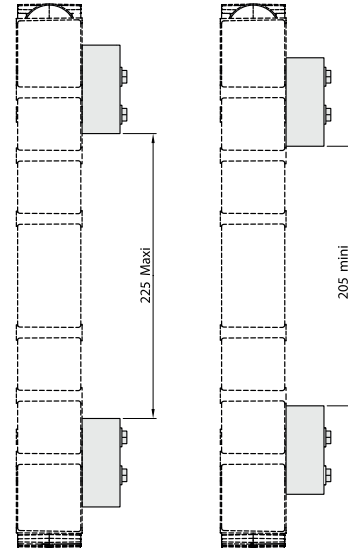
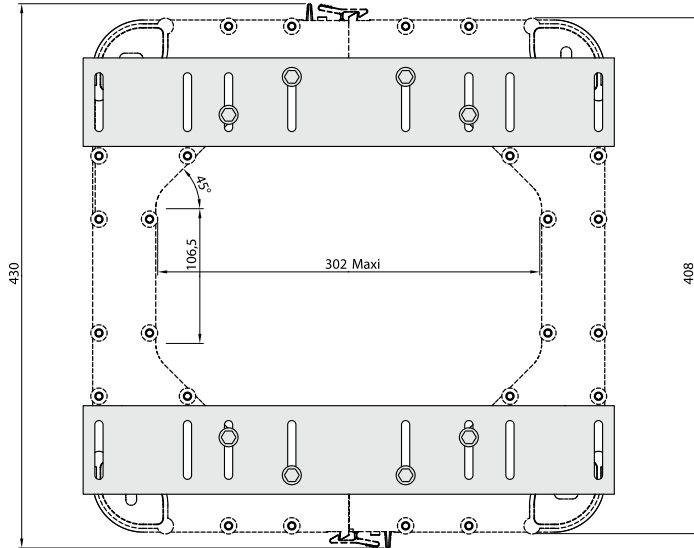

General tolerance : ± 1 mm

Side plate mounting on NCS305 sensors

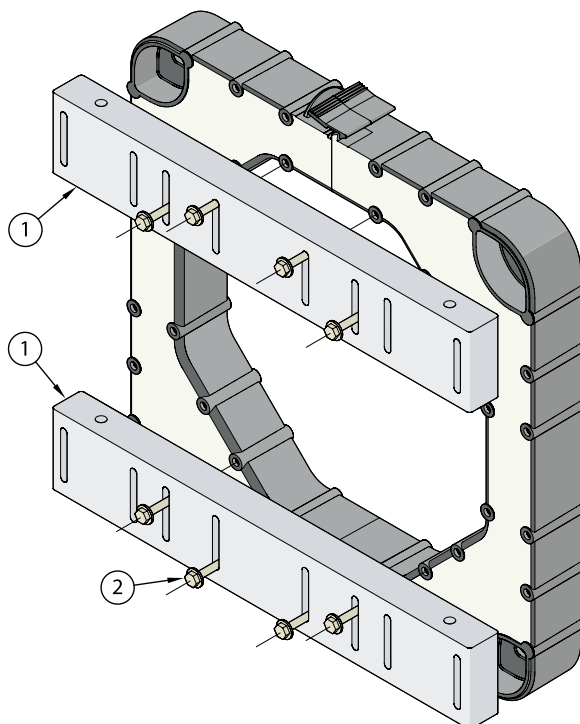

- 1 - Side plate: x2
- 2 - M6 screw: x8 (6.3x50)

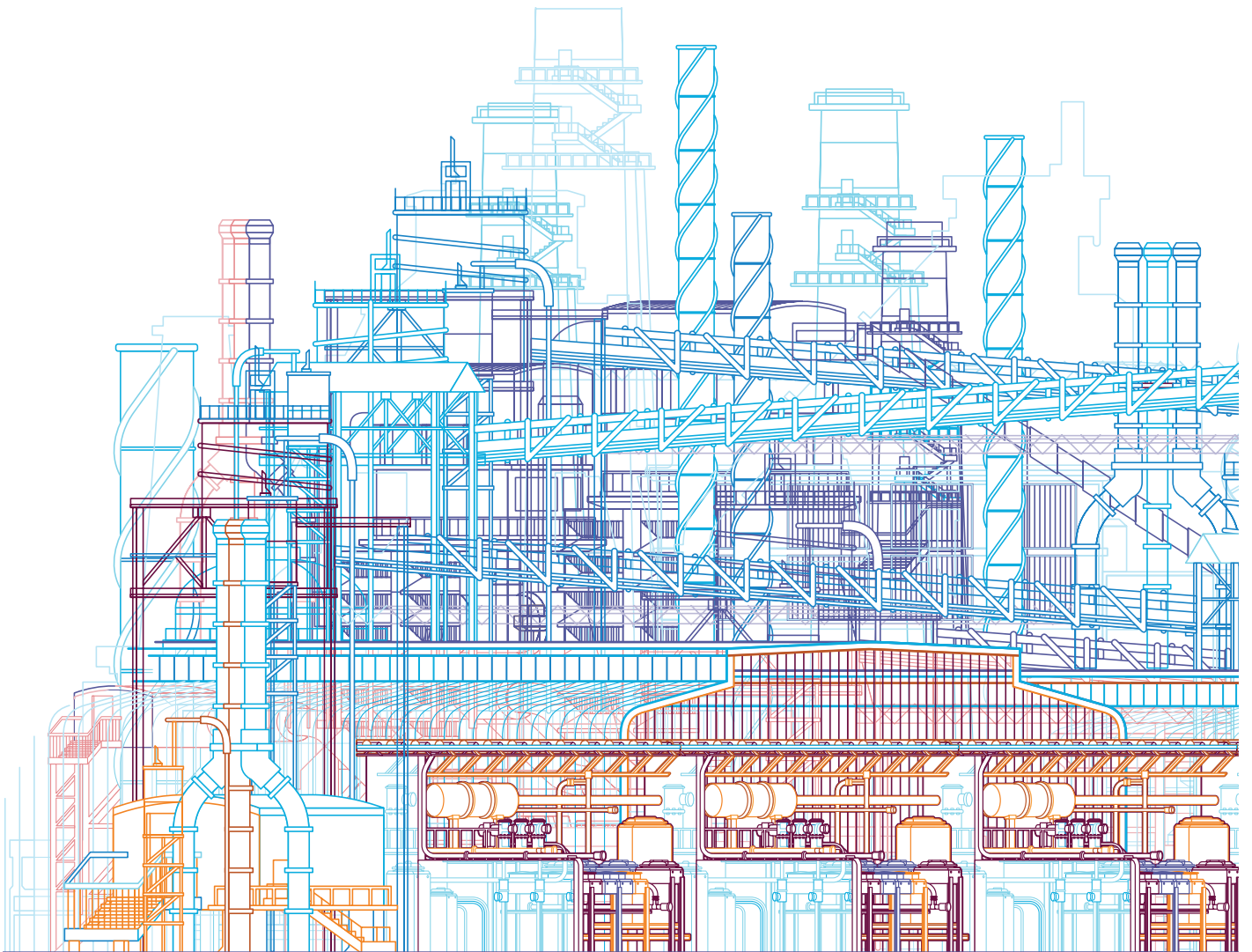

Industry current sensors HBO range

Open loop technology

2



Quality that goes beyond standards

PETERCEM have been ISO 9001 certified since 1993 and our standard

HBO sensors bear the CE label in Europe.

This ongoing striving after quality has always been the hallmark of a company where excellence and safety are part of the culture, from design right through to production.

This culture is the result of continuous research to make technical progress and meet our customers' demands.

The chief selling-point of HBO sensors is their quality. Compliance of their high-tech electronic design with standard EN 50178 is proof of their ability to comply with the most detailed constraint as well as major demands. The fact that each individual sensor is subjected to rigorous testing is proof of the importance PETERCEM attribute to quality.

Environment-friendly

PETERCEM have long been concerned with the protection of the environment, as proved by the ISO 14001 certification they received in 1998. This environmental approach is particularly noticeable in the production of the HBO range in the reduction of the number of components, in the use of a low-energy manufacturing procedure and the use of recyclable packing. The products in use are also characterized by their reduced energy consumption.

Our HBO range is RoHS compliant.

A single size for every rating

With a single size for every rating (from 100 A to 600 A), HBO current sensors give you the possibility of increasing equipment standardisation.

A precise response to customer expectations

The HBO sensor has been designed using Open Loop Hall effect technology, thereby adding a whole new type to the various sensor technologies used by PETERCEM. The HBO range enables PETERCEM to offer an additional range of sensors that are suitable for less technically demanding applications and ensure best cost competitiveness. Customers are therefore free to choose the most suitable solution for their applications.

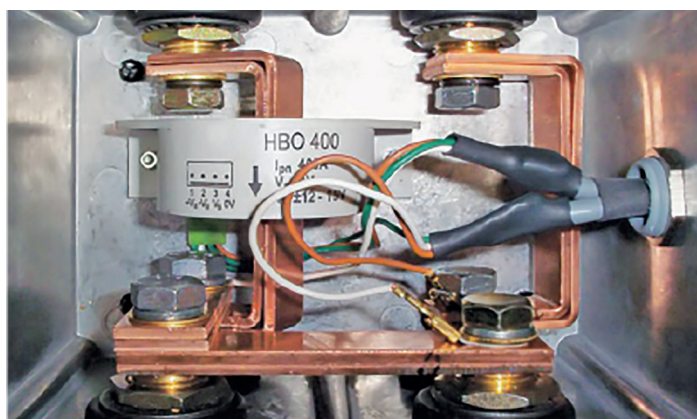

Vertical or horizontal

Assemblers can choose 2 methods of fastening PETERCEM sensors: horizontally or vertically.

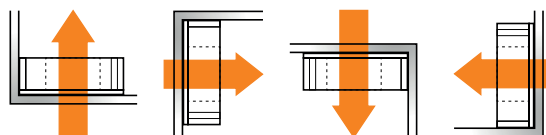

Laser-trimmed sensors, automated production

HBO100 ... HBO1000 industry current sensors

100 to 1000 A - Open loop technology

Frame mounting

These sensors are designed to be fixed by the case. They may be either vertically or horizontally mounted. The secondary connection is made with a connector. For HBO sensors the primary conductor may be a cable or a bar.



HBO100 to HBO1000

Ordering details

Nominal primary current	Secondary voltage at I_{PN}	Supply voltage	Secondary connection	Type	Order code
A r.m.s.	V	V DC			
100	±4	±12 ... ±15	Molex type 4 pin	HBO100	1SBT210100R0001
200	±4	±12 ... ±15	Molex type 4 pin	HBO200	1SBT210200R0001
300	±4	±12 ... ±15	Molex type 4 pin	HBO300	1SBT210300R0001
400	±4	±12 ... ±15	Molex type 4 pin	HBO400	1SBT210400R0001
500	±4	±12 ... ±15	Molex type 4 pin	HBO500	1SBT210500R0001
600	±4	±12 ... ±15	Molex type 4 pin	HBO600	1SBT210600R0001
1000	±4	±12 ... ±15	Molex type 4 pin	HBO1000	1SBT211000R0001

HBO100 ... HBO1000 industry current sensors

Technical data

2

Utilisation

Sensors to measure DC, AC or pulsating currents with a galvanic insulation between primary and secondary circuits.



			HBO100	HBO200	HBO300	HBO400
Nominal primary current (I_{PN})		A r.m.s.	100	200	300	400
Measuring range	@ ±15 V (±5%)	A peak	±300	±600	±900	±1100
Output voltage at I_{PN}		V	±4	±4	±4	±4
Supply voltage	±5%	V DC	±12 ... ±15	±12 ... ±15	±12 ... ±15	±12 ... ±15
Load resistance		kΩ	>1	>1	>1	>1
Internal output resistance	±5%	Ω	12	12	12	12
Current consumption		mA	≤25	≤25	≤25	≤25
Rated voltage (1)		V r.m.s.	500	500	500	500
Insulation resistance	@ 500 V DC	MΩ	>500	>500	>500	>500
Accuracy (2) AC at I_{PN}	@ +25 °C, $R_L > 10$ kΩ, ±15 V, 50 Hz	%	≤±1	≤±1	≤±1	≤±1
Accuracy (2) AC at I_{PN}	@ +25 °C, $R_L > 10$ kΩ, ±12...±15 V, 50 Hz	%	≤±1.5	≤±1.5	≤±1.5	≤±1.5
Output offset	@ +25 °C, $I_p = 0$, ±15 V	mV	≤±10	≤±10	≤±10	≤±10
Output offset	@ +25 °C, $I_p = 0$, ±12...±15 V	mV	≤±15	≤±15	≤±15	≤±15
Additional offset after an overload of I_{PMAX}	@ +25 °C, $I_p = 0$, ±15 V	mV	≤±10	≤±10	≤±10	≤±10
Output offset thermal drift	-25 ... +85 °C	mV/°C	≤±1	≤±1	≤±1	≤±1
Linearity (2)		%	≤0.5	≤0.5	≤0.5	≤0.5
Gain thermal drift	-25 ... +85 °C, @ ±15 V(±5%)	%/°C	≤0.05	≤0.05	≤0.05	≤0.05
Delay time		μs	≤3	≤3	≤3	≤3
di/dt correctly followed		A / μs	≤50	≤50	≤50	≤50
Bandwidth	-3 dB	kHz	0 ... 50	0 ... 50	0 ... 50	0 ... 50
Dielectric strength Primary/Secondary	50 Hz, 1 min	kV r.m.s.	3.5	3.5	3.5	3.5
Mass		kg	0.200	0.200	0.200	0.200
Operating temperature		°C	-25 ... +85	-25 ... +85	-25 ... +85	-25 ... +85
Storage temperature		°C	-40 ... +85	-40 ... +85	-40 ... +85	-40 ... +85

(1) Over voltage category: 3 (OV3), pollution level: 2 (PD2)

(2) Excluding the offset

General data

- Plastic case and insulating resin are self-extinguishing.
- Fixing holes in the case moulding for two positions at right angles.
- Direction of the current: A primary current flowing in the direction of the arrow results in a positive secondary output voltage on terminal VS.

Primary connection

Hole for primary conductor.

The temperature of the primary conductor in contact with the case must not exceed 100 °C.

Secondary connection

Molex HE14 4 pin connector (ref. 22-04-1041)



			HBO500	HBO600	HBO1000
Nominal primary current (I_{PN})		A r.m.s.	500	600	1000
Measuring range	@ ±15 V (±5%)	A peak	±1200	±1300	±1500
Output voltage at I_{PN}		V	±4	±4	±4
Supply voltage	±5%	VDC	±12 ... ±15	±12 ... ±15	±12 ... ±15
Load resistance		kΩ	>1	>1	>1
Internal output resistance	±5%	Ω	12	12	12
Current consumption		mA	≤25	≤25	≤25
Rated voltage (1)		V r.m.s.	500	500	500
Insulation resistance	@ 500 V DC	MΩ	>500	>500	>500
Accuracy (2) AC at I_{PN}	@ +25 °C, $R_L > 10$ kΩ, ±15 V, 50 Hz	%	≤±1	≤±1	≤±1
Accuracy (2) AC at I_{PN}	@ +25 °C, $R_L > 10$ kΩ, ±12...±15 V, 50 Hz	%	≤±1.5	≤±1.5	≤±1.5
Output offset	@ +25 °C, $I_p = 0$, ±15 V	mV	≤±10	≤±10	≤±10
Output offset	@ +25 °C, $I_p = 0$, ±12...±15 V	mV	≤±15	≤±15	≤±15
Additional offset after an overload of I_{PMAX}	@ +25 °C, $I_p = 0$, ±15 V	mV	≤±10	≤±10	≤±10
Output offset thermal drift	-25 ... +85 °C	mV/°C	≤±1	≤±1	≤±1
Linearity (2)		%	≤0.5	≤0.5	≤0.5
Gain thermal drift	-25 ... +85 °C, @ ±15 V(±5%)	%/°C	≤0.05	≤0.05	≤0.05
Delay time		μs	≤3	≤3	≤3
di/dt correctly followed		A / μs	≤50	≤50	≤50
Bandwidth	-3 dB	kHz	0 ... 50	0 ... 50	0 ... 50
Dielectric strength Primary/Secondary	50 Hz, 1 min	kV r.m.s.	3.5	3.5	3.5
Mass		kg	0.200	0.200	0.200
Operating temperature		°C	-25 ... +85	-25 ... +85	-25 ... +85
Storage temperature		°C	-40 ... +85	-40 ... +85	-40 ... +85

(1) Over voltage category: 3 (OV3), pollution level: 2 (PD2)

(2) Excluding the offset

Accessories and options

Female Molex connector

— PETERCEM order code: **1SBT210000R2001** including 10 housings and 40 crimp socket contacts

— Molex order code: socket housing: 22-01-1044; crimp socket contacts: 08-70-0057

Conformity

EN 50178



RoHS

HBO industry current sensors

Dimensions (mm)

2

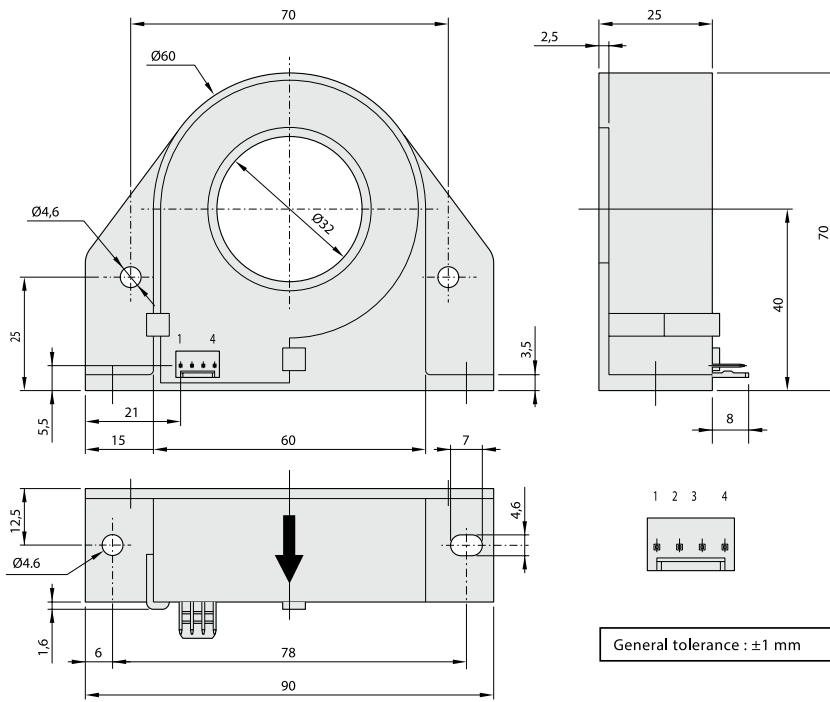

HBO100 to HBO1000

Standard HBO100 to HBO1000 sensors secondary connection

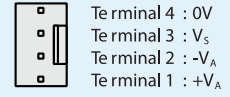

Molex Connector
(with 2.50 mm pitch)

General tolerance : ± 1 mm

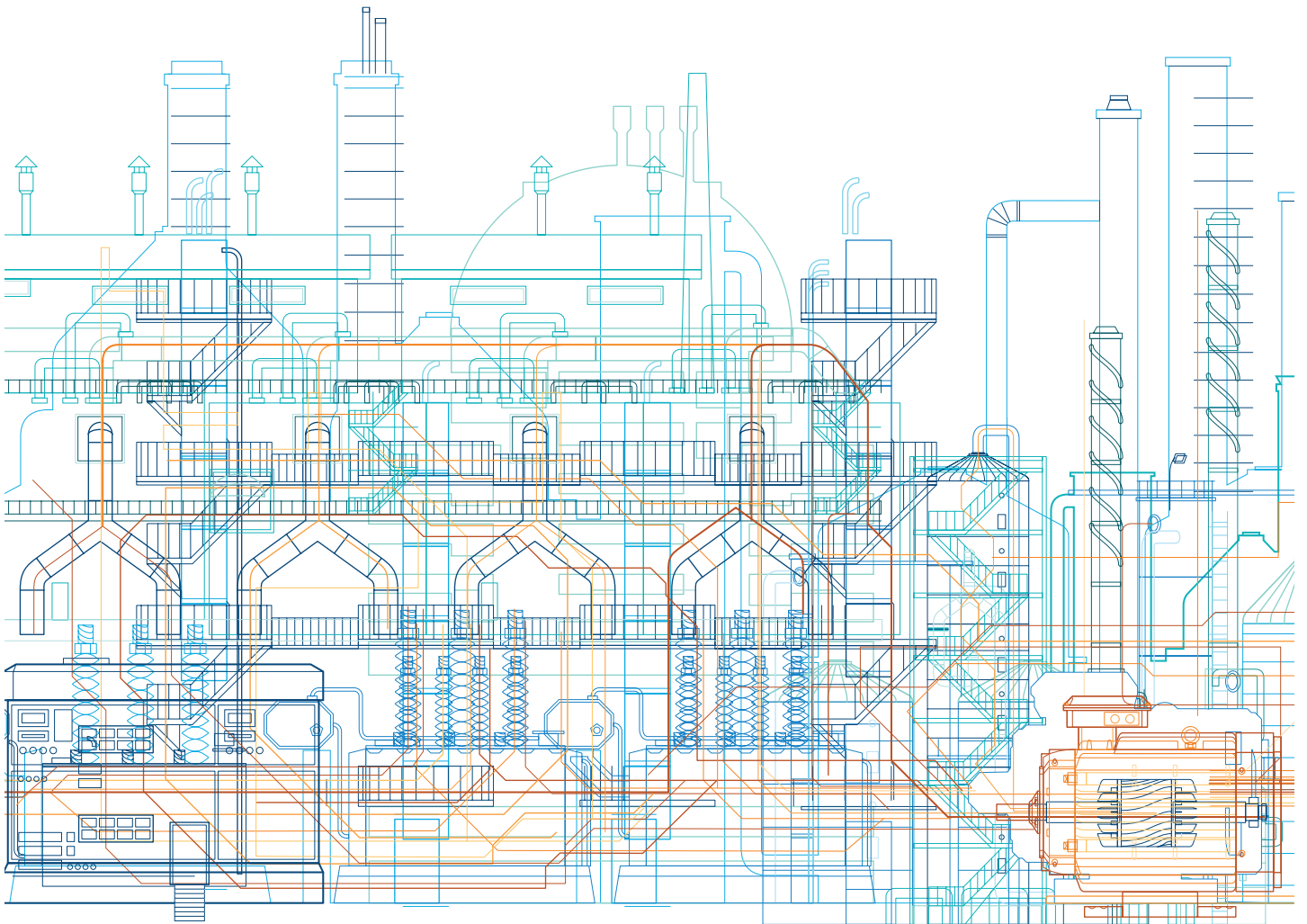

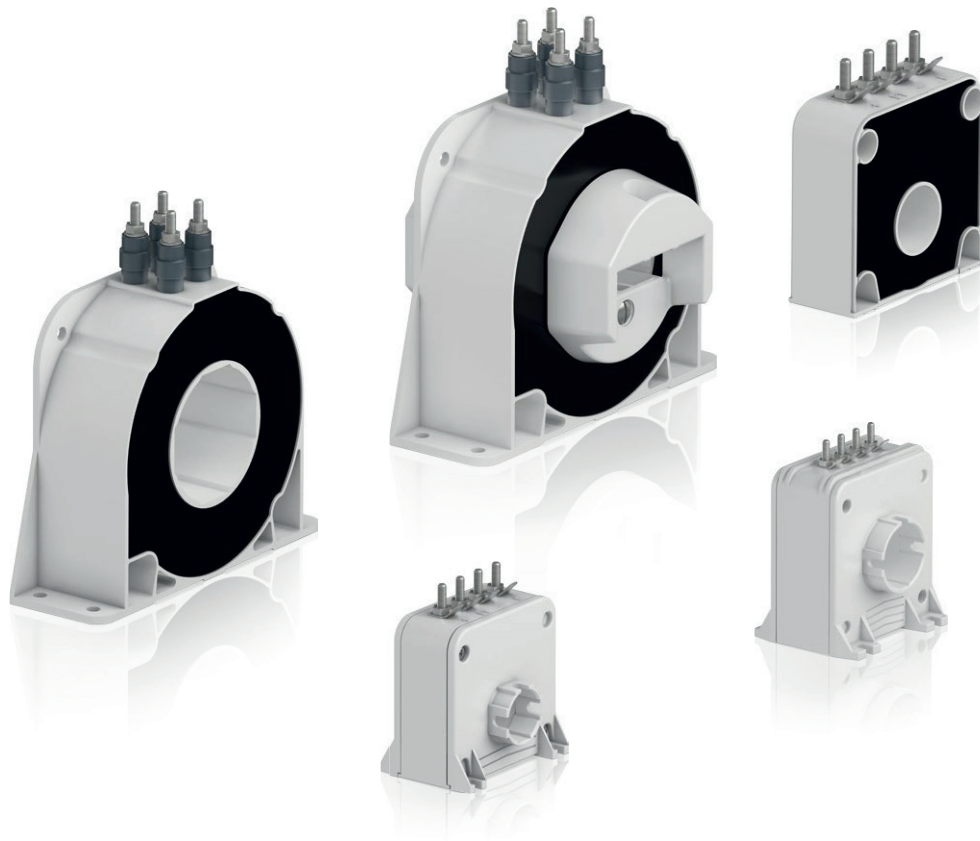

Current sensors for rolling stock and infrastructure Closed loop technology

Overview	54
CS300 ... CS2000	100 to 2000 A
Accessories and options for CS sensors	57
Technical data	58
Dimensions	60

Current sensors for infrastructure only Electronic technology

Overview	62
NCS125T ... NCS165T	4000 to 40000 A
Technical data	64
Dimensions	68

Voltage sensors for rolling stock and infrastructure

Overview	76
EM010 ... EM020	600 to 5000V
Closed loop technology	78
VS50B ... VS4200B	50 to 4200 V
Electronic technology	79
Technical data	80
Dimensions	83

Voltage detectors for rolling stock and infrastructure

Overview	84
VD1500, VD3000	25 to 3600 V
Dimensions	87

Railway current sensors CS range

Closed loop technology for rolling stock and infrastructure

Incomparable modularity

3

CS current sensors come with a complete range of options and accessories and a wealth of preset variants that have now become standard. As well as being renowned for their incomparable modularity, CS sensors give their users the edge because they are compact and easy to fit. They also offer a number of connection options, their simplicity and performance characteristics are unrivalled as are their magnetic immunity and mechanical resistance. They meet all the exacting demands of sectors as varied as railways, the mining industry and control in difficult environments such as ozone generators. CS current sensors and VS voltage sensors together constitute an offer the railway industry cannot afford to ignore.

You simply can't get any smaller!

PETERCEM current sensors contain everything needed to do the job – you don't need anything else. By integrating the philosophy of reduced size into its CS sensors, PETERCEM have brought miniaturization to a point of perfection. This miniaturization also gives great flexibility of installation as well as the best size and performance for money on the market. Small really is beautiful.

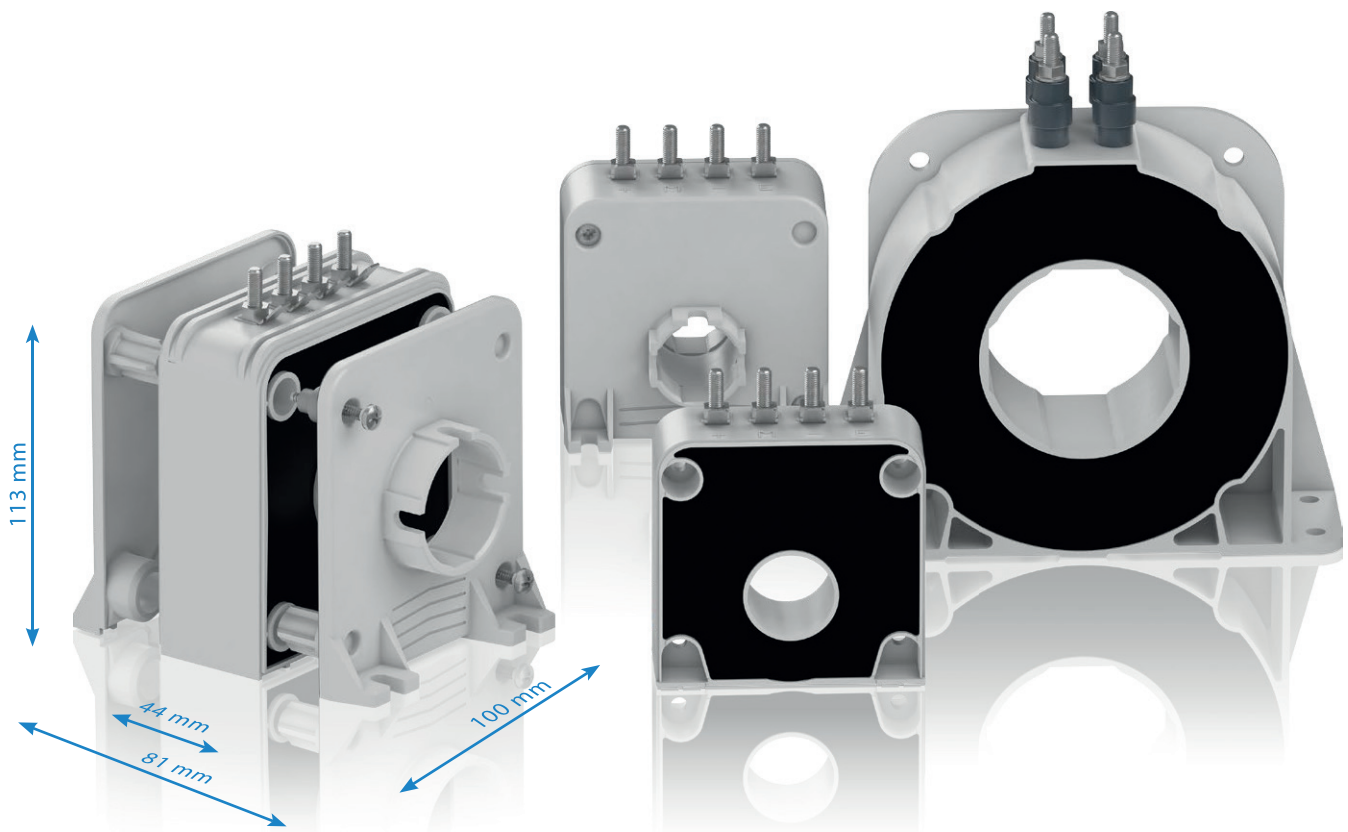

The efficient way

Once again PETERCEM have shown that they put all their know-how and talent for innovation into improving efficiency. Whether fitted horizontally or vertically, PETERCEM sensors fit perfectly into your system configurations and the space available. Installation is no longer a problem; in fact inserting sensors is child's play. This choice of fittings is a first in the sensors market. This ability to stay a length ahead makes PETERCEM stand out from their competitors.

The best way up is the way you want

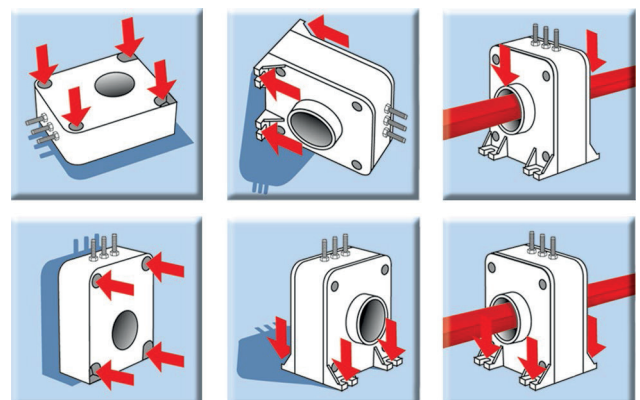

Unbeatable lifetime

Designed using the 6 sigma approach, the CS range is a model of reliability. The choice and number of optimized components, traceability of subassemblies, individually production tests... nothing is left to chance to guarantee your peace of mind.



Perfect efficiency in every environment

The CS range has been designed for applications in difficult environments such as on-board railway equipment (power converters, auxiliary converters for heating, ventilation and air conditioning) and the mining industry. Their robust design and excellent performances (e.g. operating range between -40° and $+85^{\circ}\text{C}$) make CS current sensors ideal for use in other very demanding applications (marine, wind-power, ozone generators, etc.).

Incomparable protection against magnetic fields

CS sensors are conceived, designed and renowned for their unrivalled immunity to ambient magnetic fields. Although they are in continuous proximity of powerful currents capable of distorting their measurements, this does not, in fact, occur. Their accuracy is rock-solid and once set to measure a particular current, that is what they measure – that and nothing else.

Quality that goes beyond standards

PETERCEM have been ISO 9001 certified since 1993 and our sensors bear the CE label. This ongoing striving after quality has always been the hallmark of a company where excellence and safety are part of the culture, from design right through to production.

This culture is the result of continuous research to make technical progress and meet our customers' demands.

3

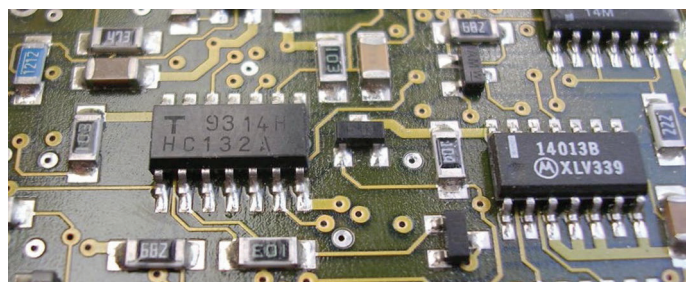

The chief selling-point of CS sensors is their quality. Compliance with EN 50121-X for electromagnetic disturbance and EN 50155 for their high-tech electronic design is proof of their ability to comply with the most detailed constraints as well as major demands. The fact that each individual sensor is subjected to rigorous testing such as sensor burn-in is proof of the importance PETERCEM attribute to quality.

CS sensors meet the various security standards in force such as EN 50124-1 for electrical insulation and NFF 16101-NFF 16102 for fire-smoke resistance.

Environment-friendly

PETERCEM have long been concerned with the protection of the environment, as proved by the ISO 14001 certification they received in 1998. This environmental approach is particularly noticeable in production of the CS range in the reduction of the number of components, in the use of a low-energy manufacturing procedure and the use of recyclable packing. The products in use are also characterized by their reduced energy consumption.



The NCS meets all of your requirements

CS300 ... CS2000 railway current sensors

Closed loop technology for rolling stock and infrastructure 100 to 2000 A

3



CS300BRE



CS300BRV

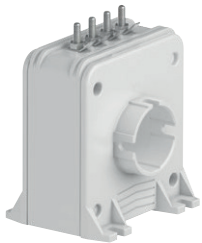

CS1000BRVE



CS2000BR



CS2000BRV

Ordering details

Nominal primary current A	Secondary current I_{SI} at $\pm I_{PN}$ mA	Supply voltage VDC	Secondary connection	Type	Order code
100	100	$\pm 15 \dots \pm 24$	3 x M5 studs // 3 x 6.35 x 0.8 Faston	CS300-9877	1SBT170300R9877
300	150	$\pm 15 \dots \pm 24$	3 x M5 studs // 3 x 6.35 x 0.8 Faston	CS300BR	1SBT170300R0001
300	150	$\pm 15 \dots \pm 24$	3 x M5 studs // 3 x 6.35 x 0.8 Faston	CS300BRV	1SBT170300R0002
300	150	$\pm 15 \dots \pm 24$	4 x M5 studs // 4 x 6.35 x 0.8 Faston	CS300BRE	1SBT170300R0003
300	150	$\pm 15 \dots \pm 24$	4 x M5 studs // 4 x 6.35 x 0.8 Faston	CS300BRVE	1SBT170300R0004
500	142.86	$\pm 15 \dots \pm 24$	3 x M5 studs // 3 x 6.35 x 0.8 Faston	CS503BR	1SBT170503R0001
500	142.86	$\pm 15 \dots \pm 24$	4 x M5 studs // 4 x 6.35 x 0.8 Faston	CS503BRE	1SBT170503R0003
500	100	$\pm 15 \dots \pm 24$	3 x M5 studs // 3 x 6.35 x 0.8 Faston	CS500BR	1SBT170500R0001
500	100	$\pm 15 \dots \pm 24$	3 x M5 studs // 3 x 6.35 x 0.8 Faston	CS500BRV	1SBT170500R0002
500	100	$\pm 15 \dots \pm 24$	4 x M5 studs // 4 x 6.35 x 0.8 Faston	CS500BRE	1SBT170500R0003
500	100	$\pm 15 \dots \pm 24$	4 x M5 studs // 4 x 6.35 x 0.8 Faston	CS500BRVE	1SBT170500R0004
1000	200	$\pm 15 \dots \pm 24$	3 x M5 studs // 3 x 6.35 x 0.8 Faston	CS1000BR	1SBT171000R0001
1000	200	$\pm 15 \dots \pm 24$	3 x M5 studs // 3 x 6.35 x 0.8 Faston	CS1000BRV	1SBT171000R0002
1000	200	$\pm 15 \dots \pm 24$	4 x M5 studs // 4 x 6.35 x 0.8 Faston	CS1000BRE	1SBT171000R0003
1000	200	$\pm 15 \dots \pm 24$	4 x M5 studs // 4 x 6.35 x 0.8 Faston	CS1000BRVE	1SBT171000R0004
1000	250	$\pm 15 \dots \pm 24$	3 x M5 studs // 3 x 6.35 x 0.8 Faston	CS1000-9940	1SBT171000R9940
1000	250	$\pm 15 \dots \pm 24$	3 x M5 studs // 3 x 6.35 x 0.8 Faston	CS1000-9941	1SBT171000R9941
1000	250	$\pm 15 \dots \pm 24$	4 x M5 studs // 4 x 6.35 x 0.8 Faston	CS1000-9942	1SBT171000R9942
1000	250	$\pm 15 \dots \pm 24$	4 x M5 studs // 4 x 6.35 x 0.8 Faston	CS1000-9943	1SBT171000R9943
2000	400	$\pm 15 \dots \pm 24$	4 x M5 studs //	CS2000BR	1SBT172000R0003
2000	400	$\pm 15 \dots \pm 24$	4 x M5 studs //	CS2000BRV	1SBT172000R0004
2000	500	$\pm 15 \dots \pm 24$	4 x M5 studs //	CS2000-9944	1SBT172000R9944
2000	500	$\pm 15 \dots \pm 24$	4 x M5 studs //	CS2000-9945	1SBT172000R9945

Accessories and options for CS sensors

Closed loop technology for rolling stock and infrastructure

Accessories

Side plates

Side plate kits include all the necessary screws for fixing the plates to the sensor.

Type	Sensor concerned	Technical description	Order code
Side plate kit CST0	CS300 & CS503	set of 2 plates	1SBT170000R2001
Side plate kit CST1	CS500 & CS1000	set of 2 plates	1SBT170000R2002
Side plate kit CST2	CS2000	set of 2 plates	1SBT170000R2007

Bar kits

Bar kits include all the necessary screws for mounting the bar on the sensor (the sensor must already be fitted with side plates prior to mounting the bar).

Type	Sensor concerned	Technical description of the bar	Order code
Bar kit CST0	CS300 & CS503	6x25x155 mm ² , 0.280 kg	1SBT170000R2003
Bar kit CST1-6	CS500 & CS1000	6x40x185 mm ² , 0.510 kg	1SBT170000R2004
Bar kit CST1-10	CS500 & CS1000	10x40x185 mm ² , 0.760 kg	1SBT170000R2005
Bar kit CST1 special	CS500 & CS1000	10x40x210 mm ² , 0.8 kg (for compatibility with TA600, TA800 et EA1000 sensors)	1SBT170000R2010
Bar kit CST2	CS2000	20x60x240 mm ² , 2.5 kg	1SBT170000R2008
Bar kit CST2 special	CS2000	20x60x370 mm ² , 3.8 kg (for compatibility with EA2000 sensors)	1SBT170000R2012

Options

Number of secondary turns Ns

Sensor	CS300	CS503	CS500
Ns	1000	4000	3500
	2500	5000	

Number of secondary turns Ns

Sensor	CS300 & CS503	CS500 & CS1000	CS2000
Secondary connection	-	-	3 M5 studs
	3 M5 inserts	3 M5 inserts	3 M5 inserts
	4 M5 inserts	4 M5 inserts	4 M5 inserts
	3 pin Lemo connector	3 pin Lemo connector	3 pin Lemo connector
	4 pin Lemo connector	4 pin Lemo connector	4 pin Lemo connector
	Shielded cable (2 m)	Shielded cable (2 m)	Shielded cable (2 m)

CS300 ... CS2000 railway current sensors

For rolling stock and infrastructure

Technical data

3

Utilisation

Sensors to measure DC, AC or pulsating currents with a galvanic insulation between primary and secondary circuits.

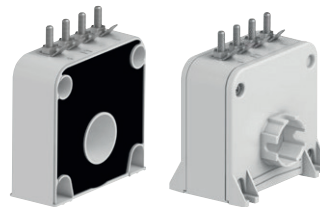

		Horizontal mounting	CS300BR	CS503BR	CS500BR
		Vertical mounting	CS300BRV	–	CS500BRV
		horizontal + Screen	CS300BRE	CS503BRE	CS500BRE
		vertical + Screen	CS300BRVE	–	CS500BRVE
Nominal primary current		A r.m.s.	300	500	500
Measuring range	@ ±15 V (±5%)	A peak	±600	–	–
Measuring range	@ ±24 V (±5%)	A peak	±600	±750	±1000
Not measurable overload	10 ms/hour	A peak	3000	5000	5000
Max. measuring resistance	@ I _{PMAX} & ±15 V (±5%)	Ω	12	–	–
Max. measuring resistance	@ I _{PMAX} & ±24 V (±5%)	Ω	40	6	37
Min. measuring resistance	@ I _{PN} & ±15 V (±5%)	Ω	0	–	–
Min. measuring resistance	@ I _{PN} & ±24 V (±5%)	Ω	35	0	0
Turn number			2000	3500	5000
Secondary current at I _{PN}		mA	150	142.86	100
Accuracy at I _{PN}	@ +25 °C	%	≤±0.5	≤±0.5	≤±0.5
Accuracy at I _{PN}	-40 ... +85 °C	%	≤±1	≤±1	≤±1
Offset current	@ +25 °C & ±24 V (±5%)	mA	≤±0.5	≤±0.3	≤±0.25
Linearity		%	≤0.1	≤0.1	≤0.1
Thermal drift coefficient	-40 ... +85 °C	µA/°C	≤7.5	≤7	≤5
Delay time		µs	≤1	≤1	≤1
di/dt correctly followed		A / µs	≤100	≤100	≤100
Bandwidth	-1 dB	kHz	≤100	≤100	≤100
Max. no-load consumption current	@ ±24 V (±5%)	mA	≤15	≤15	≤15
Secondary resistance	@ +85 °C	Ω	≤27	≤88	≤64
Dielectric strength Primary/Secondary (or Primary/(Secondary+Screen) if relevant)	50 Hz, 1 min	kV	6.5	6.5	12
Dielectric strength Secondary/Screen (if relevant)	50 Hz, 1 min	kV	0.5	0.5	0.5
Supply voltage	±5%	VDC	±15 ... ±24	±15 ... ±24	±15 ... ±24
Voltage drop		V	≤2.5	≤2.5	≤2.5
Mass		kg	0.36	0.36	0.78
Mass with side plates		kg	0.45	0.45	0.910
Operating temperature		°C	-40 ... +85	-40 ... +85	-40 ... +85
Storage temperature		°C	-50 ... +90	-50 ... +90	-50 ... +90

General data

- Plastic case and insulating resin are self-extinguishing.
- Fixing holes in the case moulding for horizontal or vertical mounting, with side plates.
- Direction of the current: A primary current flowing in the direction of the arrow results in a positive secondary output current from terminal M.
- Internal electrostatic screen: All CS sensors have an electrostatic screen, this is connected to the screen terminal "E". Depending on the version, when this screen terminal "E" is not provided, the screen is connected to the (-) terminal of the sensor.

— Protections:

- of the measuring circuit against short-circuits.
 - of the measuring circuit against opening.
 - of the power supply against polarity reversal.
- Burn-in test in accordance with FPTC 404304 cycle.

Primary connection

Hole for primary conductor. The temperature of the primary conductor in contact with the case must not exceed 100 °C.

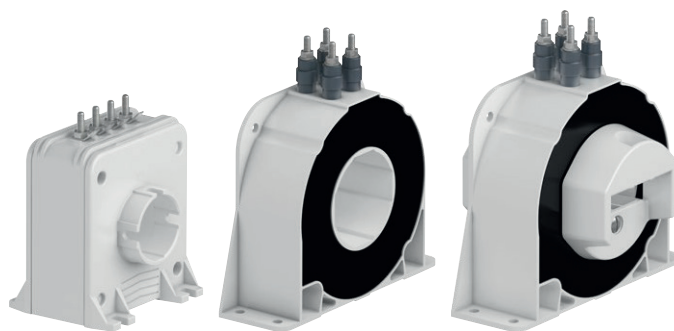

	Horizontal mounting		CS1000BR	CS1000-9940	CS2000BR*	CS2000-9944*
	Vertical mounting		CS1000BRV	CS1000-9941	CS2000BR*	CS2000-9944*
	Horizontal + Screen		CS1000BRE	CS1000-9942	CS2000BR*	CS2000-9944*
	Vertical + Screen		CS1000BRVE	CS1000-9943	CS2000BRV	CS2000-9945*
Nominal primary current		A r.m.s.	1000	1000	2000	2000
Measuring range	@ ±15 V (±5%)	A peak	–	–	–	–
Measuring range	@ ±24 V (±5%)	A peak	±2000	±2000	±3000	±3000
Not measurable overload	10 ms/hour	A peak	10000	10000	20000	20000
Max. measuring resistance	@ I _{PMAX} & ±15 V (±5%)	Ω	–	–	–	–
Max. measuring resistance	@ I _{PMAX} & ±24 V (±5%)	Ω	4	7	5	9
Min. measuring resistance	@ I _{PN} & ±15 V (±5%)	Ω	–	–	–	–
Min. measuring resistance	@ I _{PN} & ±24 V (±5%)	Ω	0	0	0	0
Turn number			5000	4000	5000	4000
Secondary current at I _{PN}		mA	200	250	400	500
Accuracy at I _{PN}	@ +25 °C	%	≤±0.5	≤±0.5	≤±0.5	≤±0.5
Accuracy at I _{PN}	-40 ... +85 °C	%	≤±1	≤±1	≤±1	≤±1
Offset current	@ +25 °C & ±24 V (±5%)	mA	≤0.25	≤0.25	≤0.25	≤0.25
Linearity		%	≤0.1	≤0.1	≤0.1	≤0.1
Thermal drift coefficient	-40 ... +85 °C	μA/°C	≤10	≤12.5	≤20	≤25
Delay time		μs	≤1	≤1	≤1	≤1
di/dt correctly followed		A / μs	≤100	≤100	≤100	≤100
Bandwidth	-1 dB	kHz	≤100	≤100	≤100	≤100
Max. no-load consumption current	@ ±24 V (±5%)	mA	≤15	≤15	≤25	≤25
Secondary resistance	@ +85 °C	Ω	≤46	≤34	≤30	≤20
Dielectric strength Primary/Secondary (or Primary/(Secondary+Screen) if relevant)	50 Hz, 1 min	kV	12	12	12	12
Dielectric strength Secondary/Screen (if relevant)	50 Hz, 1 min	kV	0.5	0.5	1.5	1.5
Supply voltage	±5%	VDC	±15 ... ±24	±15 ... ±24	±15 ... ±24	±15 ... ±24
Voltage drop		V	≤2.5	≤2.5	≤1.5	≤1.5
Mass		kg	0.85	0.85	1.5	1.5
Mass with side plates		kg	1	1	1.66	1.66
Operating temperature		°C	-40 ... +85	-40 ... +85	-40 ... +85	-40 ... +85
Storage temperature		°C	-50 ... +90	-50 ... +90	-50 ... +90	-50 ... +90

* Horizontal or vertical mounting is possible.

Standard secondary connections

M5 studs and Faston 6.35 x 0.8: see "Accessories and options" for details.

Accessories

— Side plate kits (including the fixing screws): set of 2 plates allowing for:

- Vertical or bar mounting for CS300 to CS1000
- Bar mounting for CS2000 (vertical mounting is possible without side plate for CS2000)

— Mounting bar kits (including the fixing screws) for CS300 to CS2000. See "Accessories and options" for details.

Conformity

EN 50155
EN 50121-3-2
EN 50124-1

CS300 ... CS1000 railway current sensors

For rolling stock and infrastructure

Dimensions (mm)

Horizontal mounting

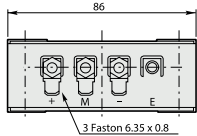
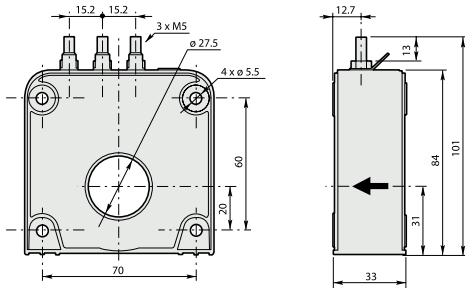

Size 0 - CS300BR
and CS503BR

Vertical mounting

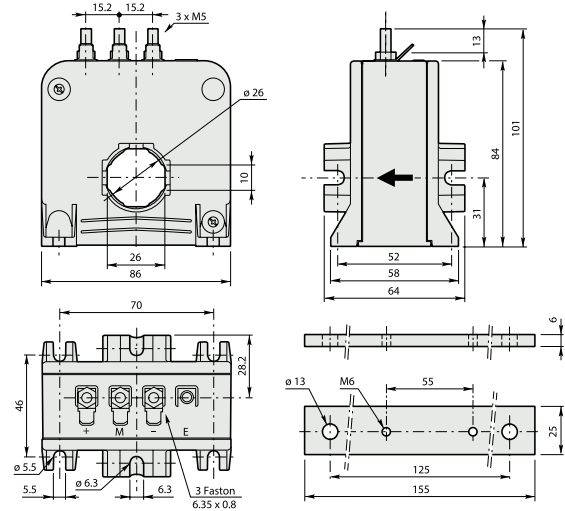

Size 0 - CS300BRV

Bar CST0

Horizontal mounting

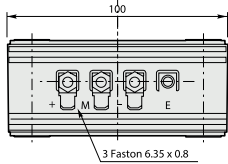
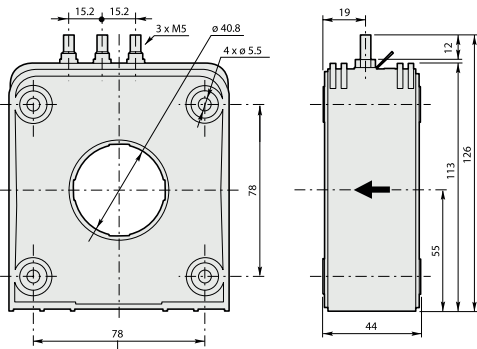

General tolerance: ±1 mm

Size 1 - CS500BR
and CS1000BR

Vertical mounting

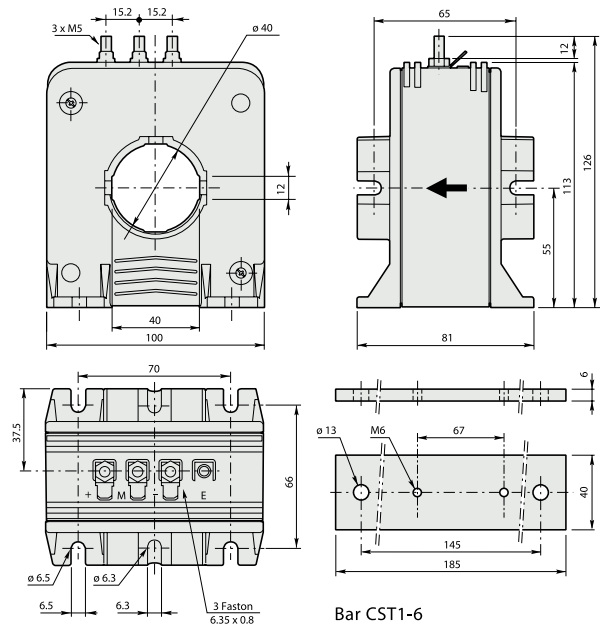

Size 1 - CS500BRV
and CS1000BRV

Bar CST1-6

General tolerance: ±1 mm

Bar CST1-10

The primary bar kit is only available with the vertical mounting versions.
Tightening torque for M5 terminal studs (N.m) : 2

CS2000 railway current sensors

For rolling stock and infrastructure

Dimensions (mm)

Horizontal and vertical mounting

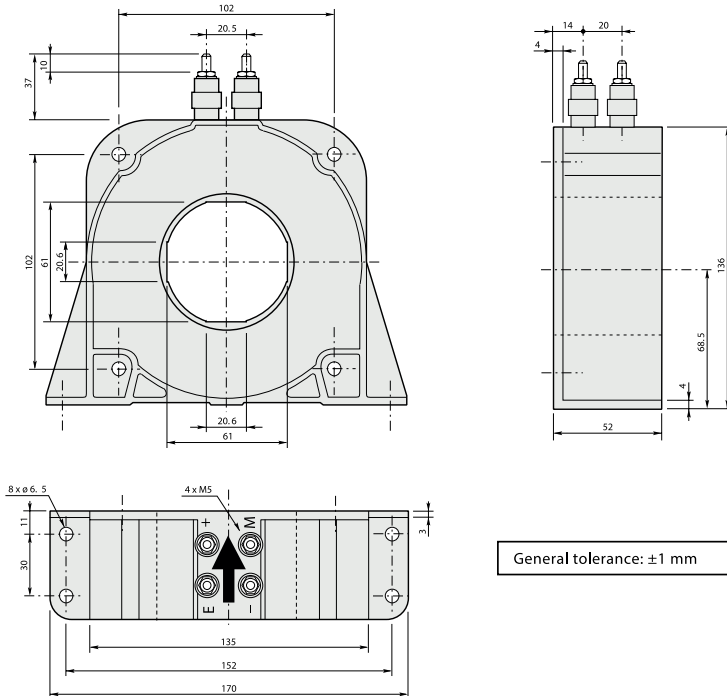

Size 2 - CS2000BR

Horizontal and vertical mounting

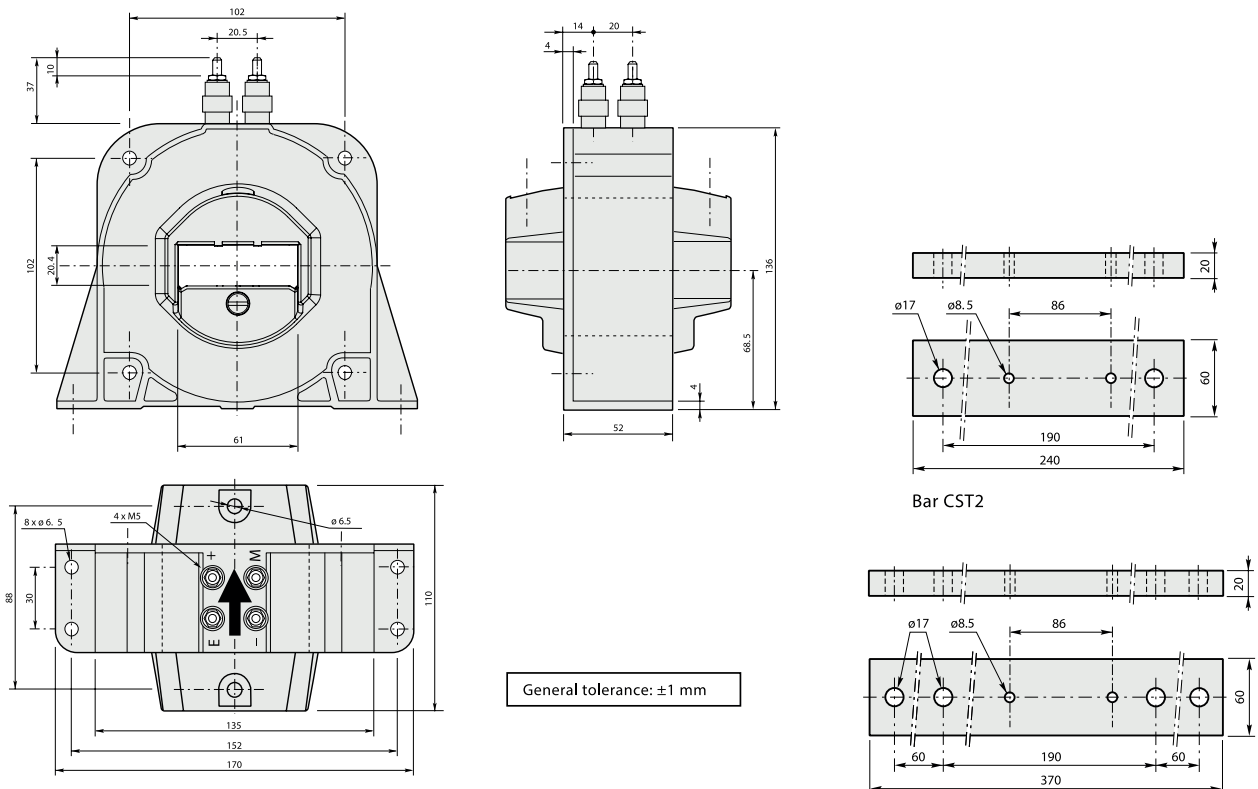

Size 2 - CS2000BRV

Railway current sensors CS range

Closed loop technology for rolling stock and infrastructure

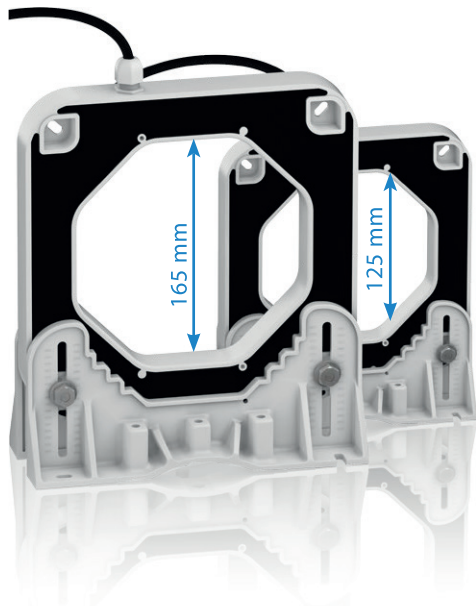

3

Designed to be integrated into every situation

The NCS sensor is entirely symmetrical. Its square shape and strategically positioned oblong holes make it easy to fasten in a choice of 2 positions. As an accessory it comes with a side plate that can be fastened on either side of the sensor giving complete fitting flexibility. It meets the standard design of PETERCEM current sensors. It can be fitted both horizontally and vertically. This flexibility means that NCS sensors can be fitted in any position and simplifies the work of integrators. Additionally the pair of right angle brackets allows the NCS sensor to be fitted to one or several bars at the same time.

100% electronic

The main advantage of the NCS range of sensors is that they are designed using a brand-new solution: 100% electronic technology. Unlike other currently available solutions such as shunts and CTs, this approach means that these sensors are very compact. Several patents were necessary to achieve this improvement.

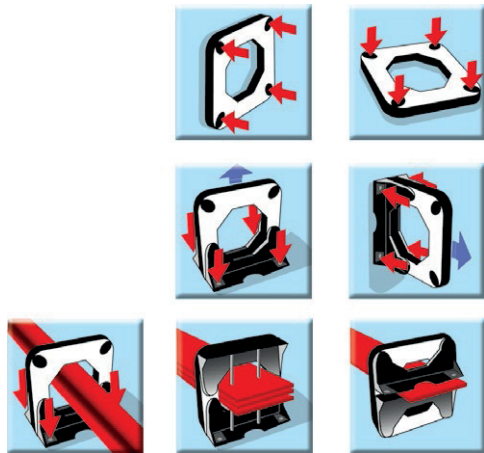

Considerable energy savings

NCS sensors offer considerable savings in energy. Indeed only a few watts are required to power the NCS sensor in contrast to traditional sensors that require several hundred watts. This reduction in wasted energy means there is no rise in temperature around the sensor.

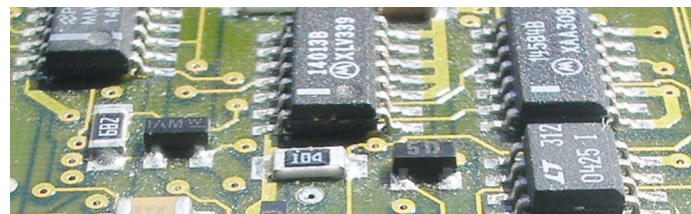

Quality that goes beyond standards

PETERCEM have been ISO 9001 certified since 1993 and our standard NCS sensors bear the CE label in Europe. This ongoing striving after quality has always been the hallmark of a company where excellence and safety are part of the culture, from design right through to production. This culture is the result of continuous research to make technical progress and meet our customers' demands.

The chief selling-point of NCS sensors is their quality. Compliance of their high-tech electronic design with standard EN 50155 is proof of their ability to comply with the most detailed constraint as well as major demands. The fact that each individual sensor is subjected to rigorous testing is proof of the importance PETERCEM attribute to quality.

Environment-friendly

PETERCEM have long been concerned with the protection of the environment, as proved by the ISO 14001 certification they received in 1998. This environmental approach is particularly noticeable in the production of the NCS range in the reduction of the number of components, in the use of a low-energy manufacturing procedure and the use of recyclable packing. The products in use are also characterized by their reduced energy consumption. Our NCST range is RoHS compliant.

NCS Substation sensors have been designed to meet the substation standards EN 50123-1 and EN 50121-5. NCS range sensors also meet the security standard EN 50124-1.

The NCS meets all of your requirements

NCS125T ... NCS165T railway current sensors

For infrastructure only

4000 to 40000 A - Electronic technology

Frame mounting

These current sensors are specially designed and manufactured for Traction applications (NCS range for fixed railway applications and CS range for rolling stock).

The requirements for these sensors are generally higher than those for Industry applications (larger operating temperature range, higher level of shocks and vibrations...).

These sensors can be fixed mechanically, by the case or by the primary bar, depending on the version or option.



NCS125T-4AF to NCS125T-10AF
NCS125T-4VF to NCS125T-10VF



NCS165T-4AF to NCS165-20AF
NCS165T-4VF to NCS165-20VF

Ordering details

Nominal primary current	Secondary current I_{S1} at $\pm I_{PN}$	Secondary voltage V_{S1} at $\pm I_{PN}$	Supply voltage	Secondary connection	Type	Order code
A	mA	V	V DC			
4000	± 20	-	± 24	Shielded cable 6 wires (2 m)	NCS125T-4AF	1SBT209204R0001
4000	-	± 10	± 24	Shielded cable 6 wires (2 m)	NCS125T-4VF	1SBT209204R0101
4000	± 20	-	± 24	Shielded cable 6 wires (2 m)	NCS165T-4AF	1SBT209604R0001
4000	-	± 10	± 24	Shielded cable 6 wires (2 m)	NCS165T-4VF	1SBT209604R0101
6000	± 20	-	± 24	Shielded cable 6 wires (2 m)	NCS125T-6AF	1SBT209206R0001
6000	-	± 10	± 24	Shielded cable 6 wires (2 m)	NCS125T-6VF	1SBT209206R0101
6000	± 20	-	± 24	Shielded cable 6 wires (2 m)	NCS165T-6AF	1SBT209606R0001
6000	-	± 10	± 24	Shielded cable 6 wires (2 m)	NCS165T-6VF	1SBT209606R0101
10000	± 20	-	± 24	Shielded cable 6 wires (2 m)	NCS125T-10AF	1SBT209210R0001
10000	-	± 10	± 24	Shielded cable 6 wires (2 m)	NCS125T-10VF	1SBT209210R0101
10000	± 20	-	± 24	Shielded cable 6 wires (2 m)	NCS165T-10AF	1SBT209610R0001
10000	-	± 10	± 24	Shielded cable 6 wires (2 m)	NCS165T-10VF	1SBT209610R0101
20000	± 20	-	± 24	Shielded cable 6 wires (2 m)	NCS165T-20AF	1SBT209620R0001
20000	-	± 10	± 24	Shielded cable 6 wires (2 m)	NCS165T-20VF	1SBT209620R0101

NCS125T railway current sensors

For infrastructure only

Technical data

3

Utilisation

Sensors to measure DC, AC or pulsating currents with a galvanic insulation between primary and secondary circuits.



	Output current shielded cable	NCS125T-4AF	-
	Output voltage shielded cable	-	NCS125T-4VF
Nominal primary current	A	4000	4000
Measuring range	A	20000	20000
Not measured overload	1 s/h	A peak	80000
Secondary current I_{S1} at I_{PN}		mA	± 20
Secondary current I_{S2} at I_{PMAX}		mA	± 20
Residual current I_{S10}	@ +25 °C	μA	$\leq \pm 250$
Residual current I_{S20}	@ +25 °C	μA	$\leq \pm 180$
Thermal drift coefficient (outputs I_{S1} , I_{S2})		$\mu A/^\circ C$	$\leq \pm 4$
Measuring resistance (outputs I_{S1} , I_{S2})		Ω	0 ... 350
Secondary voltage V_{S1} at I_{PN}		V	± 10
Secondary voltage V_{S2} at I_{PMAX}		V	± 10
Residual voltage V_{S10}	@ +25 °C	mV	$\leq \pm 100$
Residual voltage V_{S20}	@ +25 °C	mV	$\leq \pm 50$
Thermal drift coefficient (outputs V_{S1} , V_{S2})		mV/°C	$\leq \pm 2$
Measuring resistance (outputs V_{S1} , V_{S2})		Ω	10000 ... ∞
Rms accuracy 50 Hz (without offset) (1) at I_{PN}	@ +25 °C	%	$\leq \pm 1$
Rms accuracy 50 Hz (without offset) (1) at I_{PMAX}	@ +25 °C	%	$\leq \pm 3$
Gain thermal drift	-25 ... +85 °C	%/°C	≤ 0.03
Gain thermal drift	-40 ... -25 °C	%/°C	≤ 0.1
Linearity (typical)		%	± 0.5
Delay time (typical)		μs	≤ 3
di/dt correctly followed		A / μs	≤ 100
Bandwidth	@ -1 dB	kHz	0 ... 10
No load consumption current (I_{A0+})	@ -40 °C	mA	≤ 180
No load consumption current (I_{A0-})		mA	≤ 35
Dielectric strength Primary/Secondary	50 Hz, 1 min	kV r.m.s.	20
Supply voltage	$\pm 25\%$	V DC	± 24
Mass		kg	1.4
Operating temperature		°C	-40 ... +85
Storage/startup temperature		°C	-50 ... +90

(1) Maximum current I_{PN} generated: 5000 A r.m.s.

General data

- Plastic case and insulating resin are self-extinguishing.
- Two fixing modes:
 - Horizontal or vertical with fixing holes in the case moulding
 - By bar using the intermediate side plate kit (Refer to Accessories and options on the following page)
- Max tightening torque for M6 screws (side plate mounting): 2 N.m
- **Direction of the current:**
 - Output current (I_{S1} and I_{S2}): A primary current flowing in the direction of the arrow results in a positive secondary output current on terminals I_{S1} and I_{S2} .

- Output voltage (V_{S1} and V_{S2}): A primary current flowing in the direction of the arrow results in a positive secondary output voltage on terminals V_{S1} and V_{S2} .
- Burn-in test in accordance with FPTC 404304 cycle

Primary connection

Hole for primary conductor.
The temperature of the primary conductor in contact with the case must not exceed 100 °C.

Secondary connection

Shielded cable 6 x 2000 mm (cross section 0.5 mm²)



	Output current shielded cable	NCS125T-6AF	–	NCS125T-10AF	–	
	Output voltage shielded cable	–	NCS125T-6VF	–	NCS125T-10VF	
Nominal primary current	A	6000	6000	10000	10000	
Measuring range	A	30000	30000	30000	30000	
Not measured overload	1 s/h	A peak	120000	120000	200000	200000
Secondary current I _{S1} at I _{PN}		mA	±20	–	±20	–
Secondary current I _{S2} at I _{PMAX}		mA	±20	–	±20	–
Residual current I _{S10}	@ +25 °C	µA	≤±250	–	≤±250	–
Residual current I _{S20}	@ +25 °C	µA	≤±180	–	≤±180	–
Thermal drift coefficient (outputs I _{S1} , I _{S2})		µA/°C	≤±4	–	≤±4	–
Measuring resistance (outputs I _{S1} , I _{S2})		Ω	0 ... 350	–	0 ... 350	–
Secondary voltage V _{S1} at I _{PN}		V	–	±10	–	±10
Secondary voltage V _{S2} at I _{PMAX}		V	–	±10	–	±10
Residual voltage V _{S10}	@ +25 °C	mV	–	≤±100	–	≤±100
Residual voltage V _{S20}	@ +25 °C	mV	–	≤±50	–	≤±50
Thermal drift coefficient (outputs V _{S1} , V _{S2})		mV/°C	–	≤±2	–	≤±2
Measuring resistance (outputs V _{S1} , V _{S2})		Ω	–	10000 ... ∞	–	10000 ... ∞
Rms accuracy 50 Hz (without offset) (1) at I _{PN}	@ +25 °C	%	≤±1	≤±1	≤±1	≤±1
Rms accuracy 50 Hz (without offset) (1) at I _{PMAX}	@ +25 °C	%	≤±3	≤±3	≤±3	≤±3
Gain thermal drift	-25 ... +85 °C	%/°C	≤0.03	≤0.03	≤0.03	≤0.03
Gain thermal drift	-40 ... -25 °C	%/°C	≤0.1	≤0.1	≤0.1	≤0.1
Linearity (typical)		%	±0.5	±0.5	±0.5	±0.5
Delay time (typical)		µs	≤3	≤3	≤3	≤3
di/dt correctly followed		A / µs	≤100	≤100	≤100	≤100
Bandwidth	@ -1 dB	kHz	0 ... 10	0 ... 10	0 ... 10	0 ... 10
No load consumption current (I _{A0+})	@ -40 °C	mA	≤180	≤180	≤180	≤180
No load consumption current (I _{A0-})		mA	≤35	≤35	≤35	≤35
Dielectric strength Primary/Secondary	50 Hz, 1 min	kV r.m.s.	20	20	20	20
Supply voltage	± 25%	V DC	±24	±24	±24	±24
Mass		kg	1.4	1.4	1.4	1.4
Operating temperature		°C	-40 ... +85	-40 ... +85	-40 ... +85	-40 ... +85
Storage/startup temperature		°C	-50 ... +90	-50 ... +90	-50 ... +90	-50 ... +90

(1) Maximum current I_{PN} generated: 5000 A r.m.s.

Accessories and options

Side plates (or right angle brackets)

For installation of the side plates, please refer to the mounting instructions ref. **1SBC146005M1701**

Side plate kit NCS125T:
PETERCEM order code: **1SBT200000R2002**

Conformity

EN 50155
EN 50121-5, EN50123-1, EN50124-1

CE
RoHS

NCS165T railway current sensors

For infrastructure only

Technical data

3

Utilisation

Sensors to measure DC, AC or pulsating currents with a galvanic insulation between primary and secondary circuits.



			Output current shielded cable		Output voltage shielded cable	
			NCS165T-4AF	-	NCS165T-4VF	-
Nominal primary current		A	4000	4000	6000	6000
Measuring range		A	20000	20000	30000	30000
Not measured overload	1 s/h	A peak	80000	80000	120000	120000
Secondary current I_{S1} at I_{PN}		mA	± 20	-	± 20	-
Secondary current I_{S2} at $I_{P_{MAX}}$		mA	± 20	-	± 20	-
Residual current I_{S10}	@ +25 °C	μA	$\leq \pm 250$	-	$\leq \pm 250$	-
Residual current I_{S20}	@ +25 °C	μA	$\leq \pm 180$	-	$\leq \pm 180$	-
Thermal drift coefficient (outputs I_{S1} , I_{S2})		$\mu A/^\circ C$	$\leq \pm 4$	-	$\leq \pm 4$	-
Measuring resistance (outputs I_{S1} , I_{S2})		Ω	0 ... 350	-	0 ... 350	-
Secondary voltage V_{S1} at I_{PN}		V	-	± 10	-	± 10
Secondary voltage V_{S2} at $I_{P_{MAX}}$		V	-	± 10	-	± 10
Residual voltage V_{S10}	@ +25 °C	mV	-	$\leq \pm 100$	-	$\leq \pm 100$
Residual voltage V_{S20}	@ +25 °C	mV	-	$\leq \pm 50$	-	$\leq \pm 50$
Thermal drift coefficient (outputs V_{S1} , V_{S2})		mV/°C	-	$\leq \pm 2$	-	$\leq \pm 2$
Measuring resistance (outputs V_{S1} , V_{S2})		Ω	-	10000 ... ∞	-	10000 ... ∞
Rms accuracy 50 Hz (without offset) (1) at I_{PN}	@ +25 °C	%	$\leq \pm 1$	$\leq \pm 1$	$\leq \pm 1$	$\leq \pm 1$
Rms accuracy 50 Hz (without offset) (1) at $I_{P_{MAX}}$	@ +25 °C	%	$\leq \pm 3$	$\leq \pm 3$	$\leq \pm 3$	$\leq \pm 3$
Gain thermal drift	-25 ... +85 °C	%/°C	≤ 0.03	≤ 0.03	≤ 0.03	≤ 0.03
Gain thermal drift	-40 ... -25 °C	%/°C	≤ 0.1	≤ 0.1	≤ 0.1	≤ 0.1
Linearity (typical)		%	± 0.5	± 0.5	± 0.5	± 0.5
Delay time (typical)		μs	≤ 3	≤ 3	≤ 3	≤ 3
di/dt correctly followed		A / μs	≤ 100	≤ 100	≤ 100	≤ 100
Bandwidth	@ -1 dB	kHz	0 ... 10	0 ... 10	0 ... 10	0 ... 10
No load consumption current (I_{A0+})	@ -40 °C	mA	≤ 210	≤ 210	≤ 210	≤ 210
No load consumption current (I_{A0-})		mA	≤ 35	≤ 35	≤ 35	≤ 35
Dielectric strength Primary/Secondary	50 Hz, 1 min	kV r.m.s.	20	20	20	20
Supply voltage	$\pm 25\%$	V DC	± 24	± 24	± 24	± 24
Mass		kg	1.7	1.7	1.7	1.7
Operating temperature		°C	-40 ... +85	-40 ... +85	-40 ... +85	-40 ... +85
Storage/startup temperature		°C	-50 ... +90	-50 ... +90	-50 ... +90	-50 ... +90

(1) Maximum current I_{PN} generated: 5000 A r.m.s.

General data

- Plastic case and insulating resin are self-extinguishing.
- Two fixing modes:
 - Horizontal or vertical with fixing holes in the case moulding.
 - By bar using the intermediate side plate kit (Refer to accessories and options on the following page)
- Max tightening torque for M6 screws (side plate mounting): 2 N.m
- **Direction of the current:**
 - Output current (I_{S1} and I_{S2}): A primary current flowing in the direction of the arrow results in a positive secondary output current on terminals I_{S1} and I_{S2} .

- Output voltage (V_{S1} and V_{S2}): A primary current flowing in the direction of the arrow results in a positive secondary output voltage on terminals V_{S1} and V_{S2} .

— Burn-in test in accordance with FPTC 404304 cycle

Primary connection

Hole for primary conductor.
The temperature of the primary conductor in contact with the case must not exceed 100 °C.

Secondary connection

Shielded cable 6 x 2000 mm (cross section 0.5 mm²)



			Output current shielded cable		Output voltage shielded cable	
			NCS165T-10AF	-	NCS165T-10VF	NCS165T-20AF
Nominal primary current		A	10000	10000	20000	20000
Measuring range		A	30000	30000	40000	40000
Not measured overload	1 s/h	A peak	200000	200000	200000	200000
Secondary current I _{S1} at I _{PN}		mA	±20	-	±20	-
Secondary current I _{S2} at I _{PMAX}		mA	±20	-	±20	-
Residual current I _{S10}	@ +25 °C	µA	≤±250	-	≤±250	-
Residual current I _{S20}	@ +25 °C	µA	≤±180	-	≤±180	-
Thermal drift coefficient (outputs I _{S1} , I _{S2})		µA/°C	≤±4	-	≤±4	-
Measuring resistance (outputs I _{S1} , I _{S2})		Ω	0 ... 350	-	0 ... 350	-
Secondary voltage V _{S1} at I _{PN}		V	-	±10	-	±10
Secondary voltage V _{S2} at I _{PMAX}		V	-	±10	-	±10
Residual voltage V _{S10}	@ +25 °C	mV	-	≤±100	-	≤±100
Residual voltage V _{S20}	@ +25 °C	mV	-	≤±50	-	≤±50
Thermal drift coefficient (outputs V _{S1} , V _{S2})		mV/°C	-	≤±2	-	≤±2
Measuring resistance (outputs V _{S1} , V _{S2})		Ω	-	10000 ... ∞	-	10000 ... ∞
Rms accuracy 50 Hz (without offset) ¹ at I _{PN}	@ +25 °C	%	≤±1	≤±1	≤±1	≤±1
Rms accuracy 50 Hz (without offset) ¹ at I _{PMAX}	@ +25 °C	%	≤±3	≤±3	≤±3	≤±3
Gain thermal drift	-25 ... +85 °C	%/°C	≤0.03	≤0.03	≤0.03	≤0.03
Gain thermal drift	-40 ... -25 °C	%/°C	≤0.1	≤0.1	≤0.1	≤0.1
Linearity (typical)		%	±0.5	±0.5	±0.5	±0.5
Delay time (typical)		µs	≤3	≤3	≤3	≤3
di/dt correctly followed		A / µs	≤100	≤100	≤100	≤100
Bandwidth	@ -1 dB	kHz	0 ... 10	0 ... 10	0 ... 10	0 ... 10
No load consumption current (I _{A0+})	@ -40 °C	mA	≤210	≤210	≤210	≤210
No load consumption current (I _{A0-})		mA	≤35	≤35	≤35	≤35
Dielectric strength Primary/Secondary	50 Hz, 1 min	kV r.m.s.	20	20	20	20
Supply voltage	± 25%	VDC	±24	±24	±24	±24
Mass		kg	1.7	1.7	1.7	1.7
Operating temperature		°C	-40 ... +85	-40 ... +85	-40 ... +85	-40 ... +85
Storage/startup temperature		°C	-50 ... +90	-50 ... +90	-50 ... +90	-50 ... +90

(1) Maximum current I_{PN} generated: 5000 A r.m.s.

Accessories and options

Side plates (or right angle brackets)

For installation of the side plates, please refer to the mounting instructions ref. **1SBC146004M1701**

Side plate kit NCS165T:
PETERCEM order code: **1SBT200000R2001**

Conformity

EN 50155
EN 50121-5, EN 50123-1, EN 50124-1

CE
RoHS

NCS125T railway current sensors

For infrastructure only

Dimensions (mm)

3

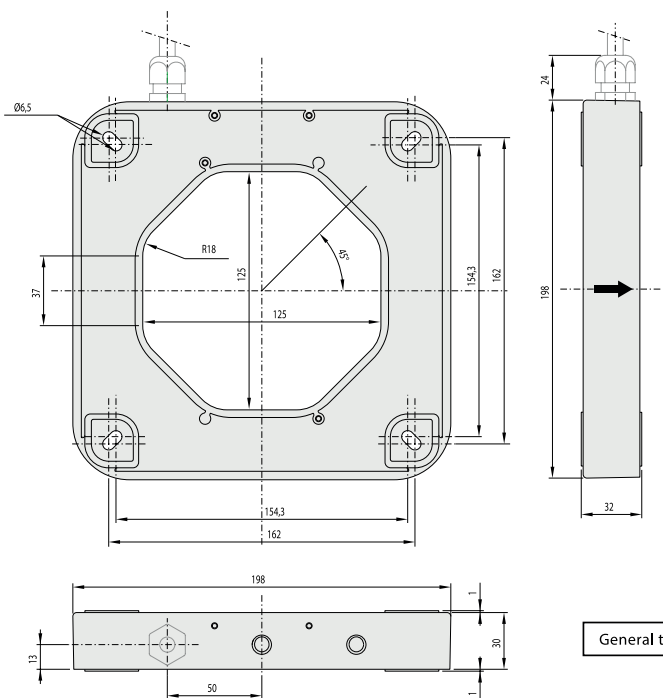

NCS125T-AF

Standard NCS125T-AF sensors secondary connection

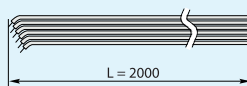

Shielded cable with braided earth

AF range wires identification

- 1 : Red: +V_A (+24 V DC)
- 2 : Black: 0 V
- 3 : Blue: -V_A (-24 V DC)
- 4 : NC:
- 5 : NC:
- 6 : Green: I_{S1} (±20 mA @ I_{PN})
- 7 : White: I_{S2} (±20 mA @ I_{PMAX})
- 8 : Brown: 0 V

Shielding: see instructions for mounting and wiring

General tolerance: ±1 mm

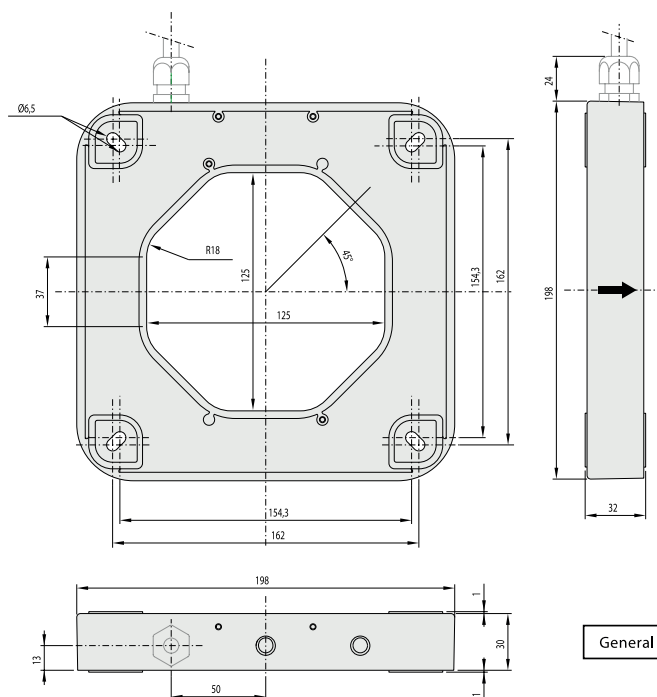

NCS125T-VF

Standard NCS125T-VF sensors secondary connection

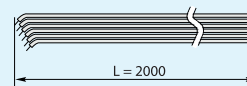

Shielded cable with braided earth

VF range wires identification

- 1 : Red: +V_A (+24 V DC)
- 2 : Black: 0 V
- 3 : Blue: -V_A (-24 V DC)
- 4 : Green: V_{S1} (±10 V @ I_{PN})
- 5 : White: V_{S2} (±10 V @ I_{PMAX})
- 6 : NC:
- 7 : NC:
- 8 : Brown: 0 V

Shielding: see instructions for mounting and wiring

General tolerance: ±1 mm

NCS125T railway current sensors

For infrastructure only

Dimensions and arrangement of right angle brackets (mm)

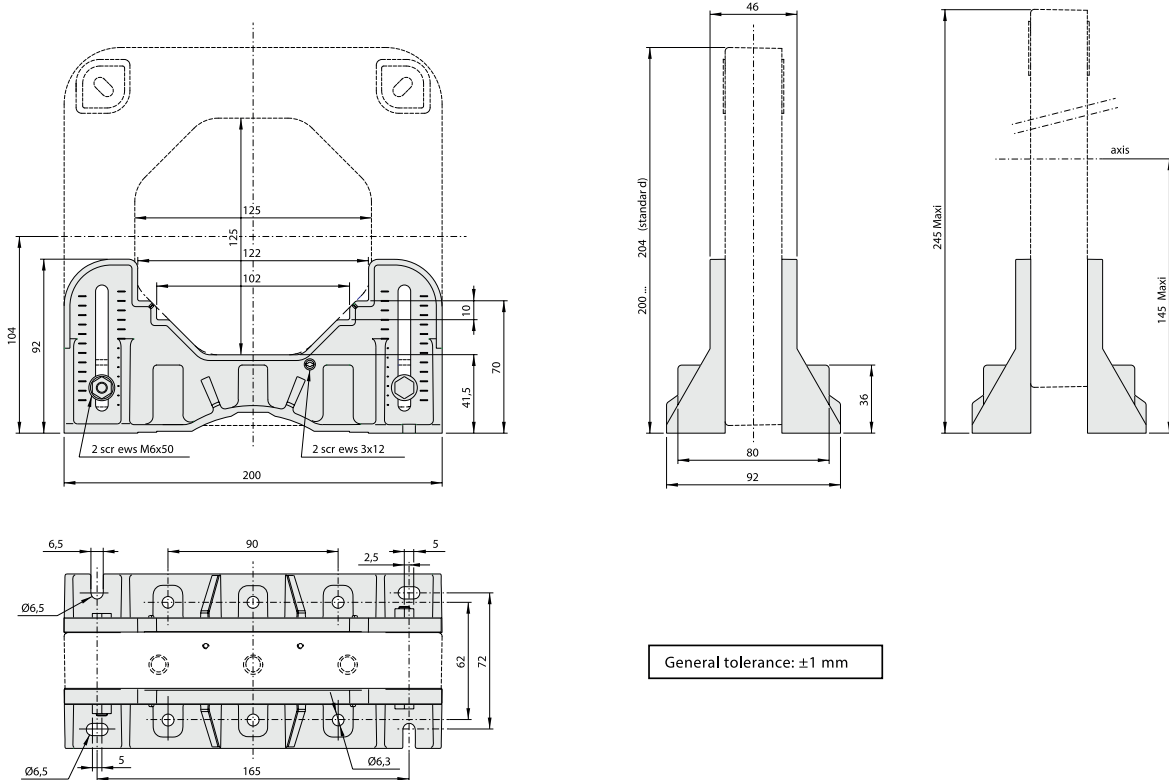

Right angle brackets mounting on NCS125T sensors

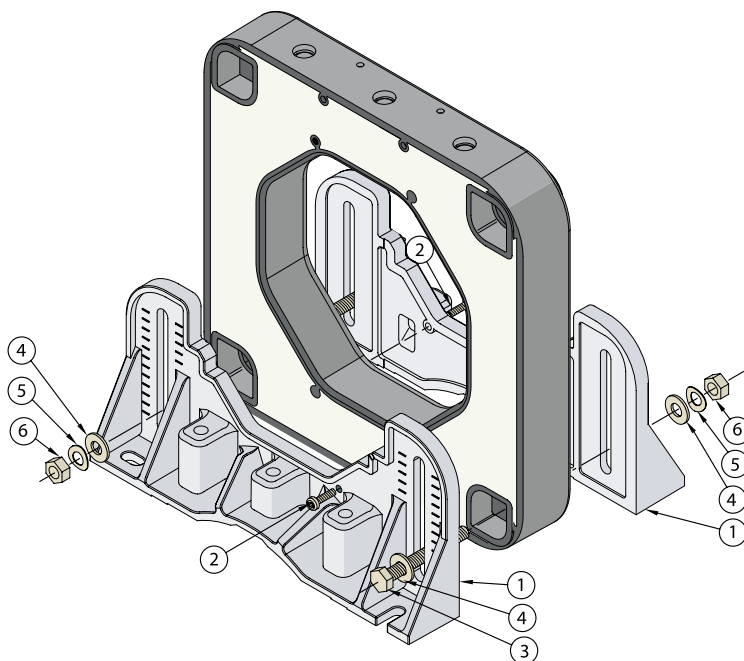

- 1 - Side plate: x2
- 2 - Standard positioning screw: x2 (3x12)
- 3 - Side plate screw M6: x2 (6x50)
- 4 - Flat washer: x4
- 5 - Spring washer: x2
- 6 - Locknut: x2
- 7 - Not used:
 - Side plate screw M6: x4 (6x30)
 - Flat washer: x4
 - Spring washer: x2
 - Locknut: x2

NCS125T railway current sensors

For infrastructure only

Dimensions and arrangement of right angle brackets (mm)

3

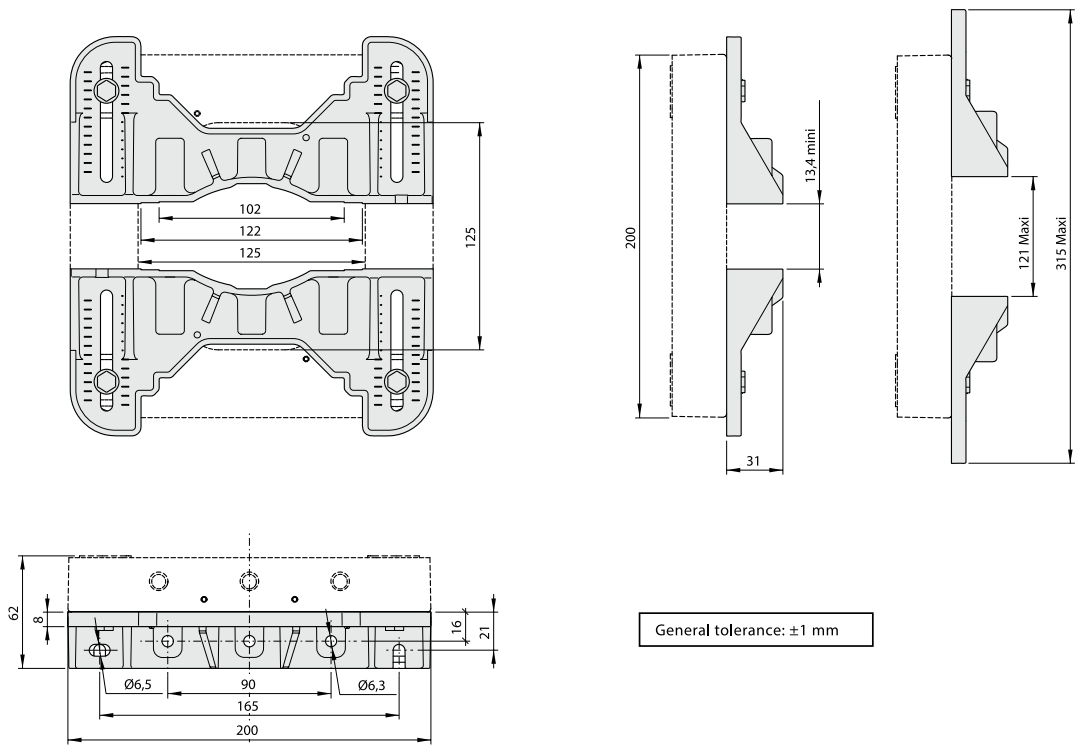

Right angle brackets mounting on NCS125T sensors

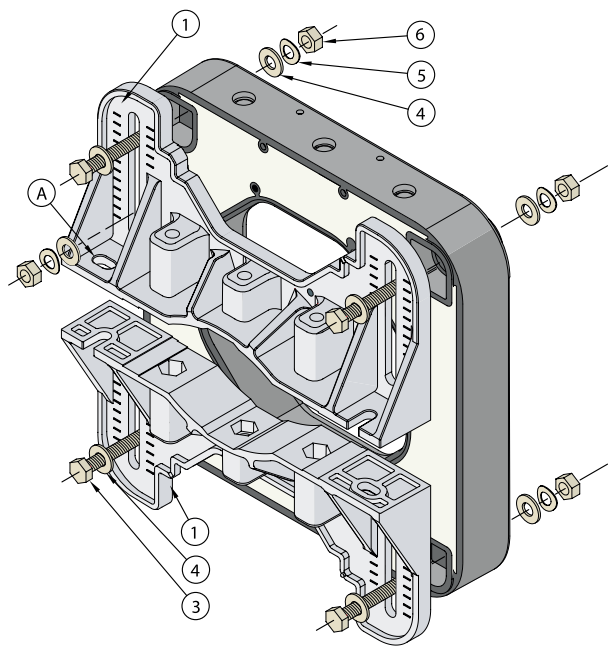

- 1 - Side plate: x2
- 3 - Side plate screw M6: x4 (6x30)
- 4 - Flat washer: x8
- 5 - Spring washer: x4
- 6 - Locknut: x4
- 7 - Not used:
 - Side plate screw M6: x4 (6x50)
 - Standard positioning screw: x2 (3x12)

A - The screws for clamping the side plates to the bar (or cable) are not supplied

NCS125T railway current sensors

For infrastructure only

Dimensions and arrangement of right angle brackets (mm)

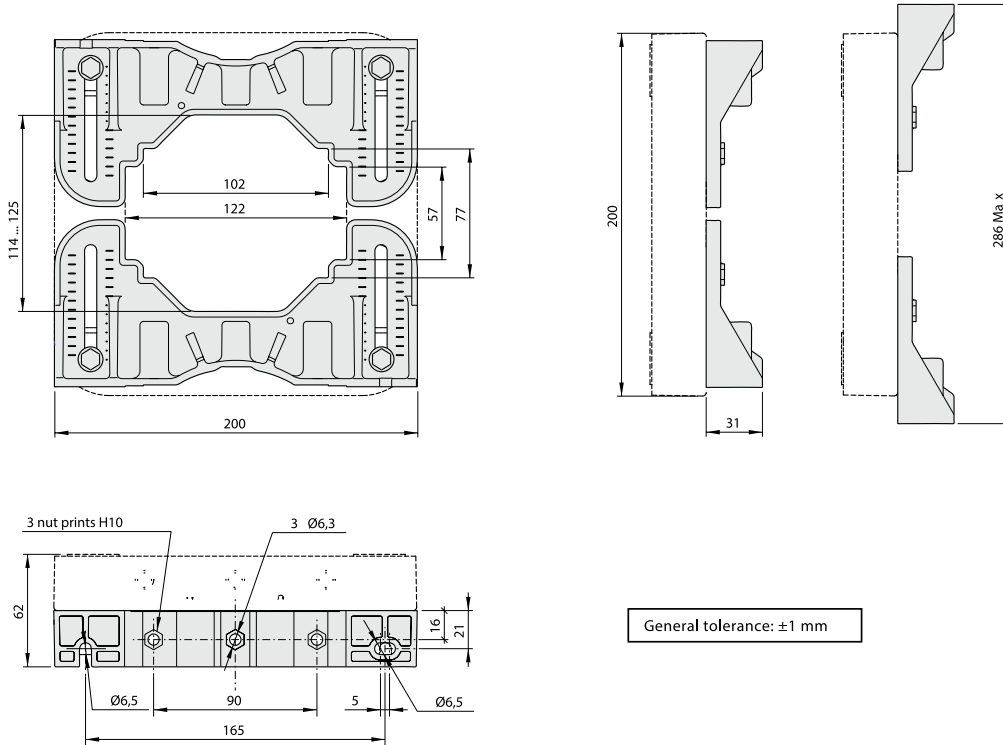

Right angle brackets mounting on NCS125T sensors

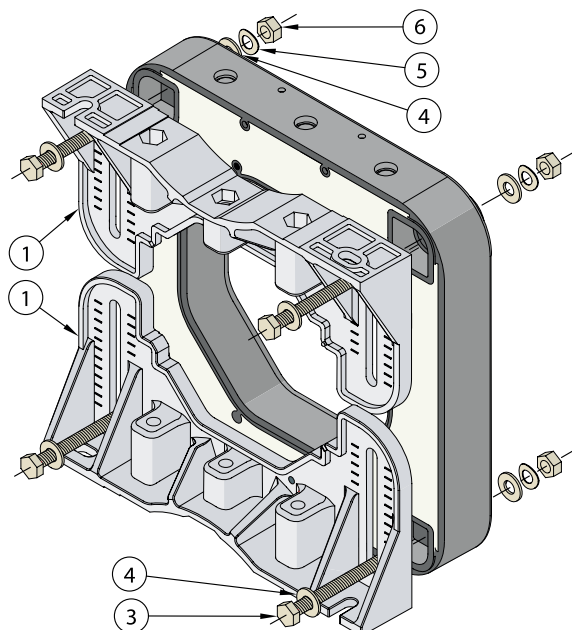

- 1 - Side plate: x2
- 3 - Side plate screw M6: x4 (6x30)
- 4 - Flat washer: x8
- 5 - Spring washer: x4
- 6 - Locknut: x4
- 7 - Not used:
 - Side plate screw M6: x2 (6x50)
 - Standard positioning screw: x2 (3x12)

NCS165T railway current sensors

For infrastructure only

Dimensions (mm)

3

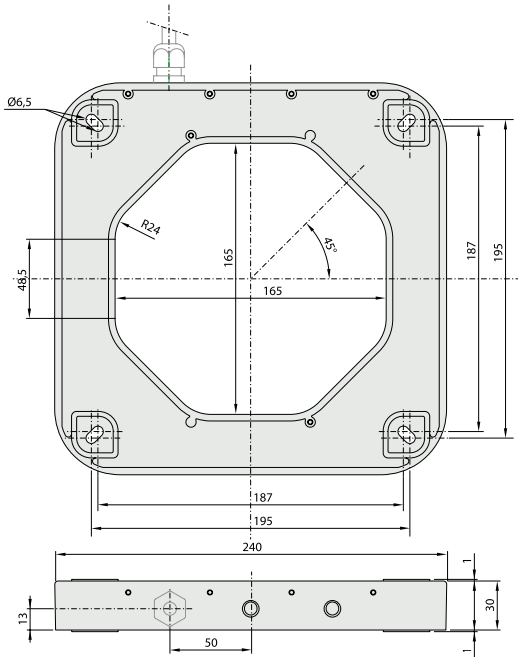

NCS165T-AF

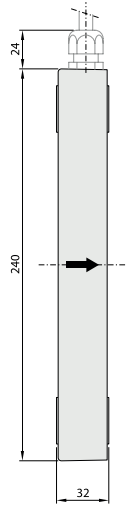

Standard NCS165T-AF sensors secondary connection

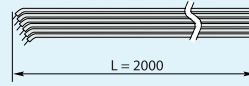

Shielded cable with braided earth

AF range wires identification

- 1 : Red: +V_A (+24 V DC)
- 2 : Black: 0 V
- 3 : Blue: -V_A (-24 V DC)
- 4 : NC:
- 5 : NC:
- 6 : Green: I_{S1} (±20 mA @ I_{PN})
- 7 : White: I_{S2} (±20 mA @ I_{PMAX})
- 8 : Brown: 0 V

Shielding: see instructions for mounting and wiring

General tolerance: ±1 mm

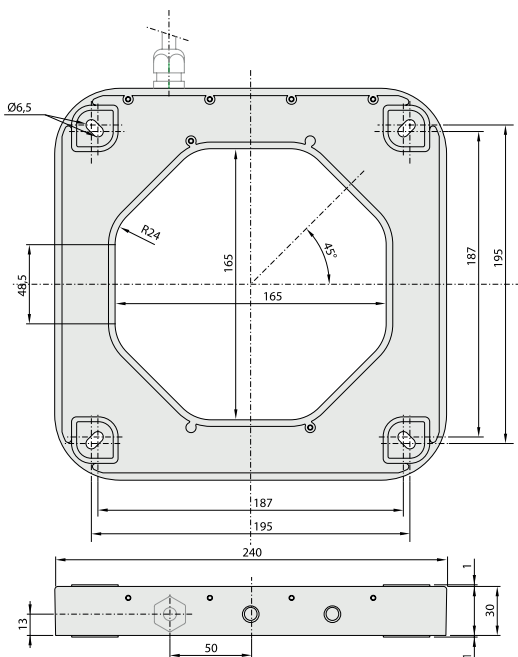

NCS165T-VF

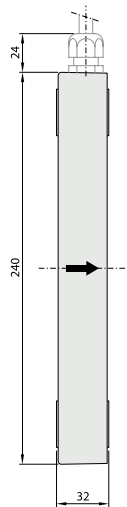

Standard NCS165T-VF sensors secondary connection

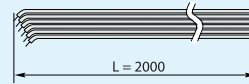

Shielded cable with braided earth

VF range wires identification

- 1 : Red: +V_A (+24 V DC)
- 2 : Black: 0 V
- 3 : Blue: -V_A (-24 V DC)
- 4 : Green: V_{S1} (±10 V @ I_{PN})
- 5 : White: V_{S2} (±10 V @ I_{PMAX})
- 6 : NC:
- 7 : NC:
- 8 : Brown: 0 V

Shielding: see instructions for mounting and wiring

General tolerance: ±1 mm

NCS165T railway current sensors

For infrastructure only

Dimensions and arrangement of right angle brackets (mm)

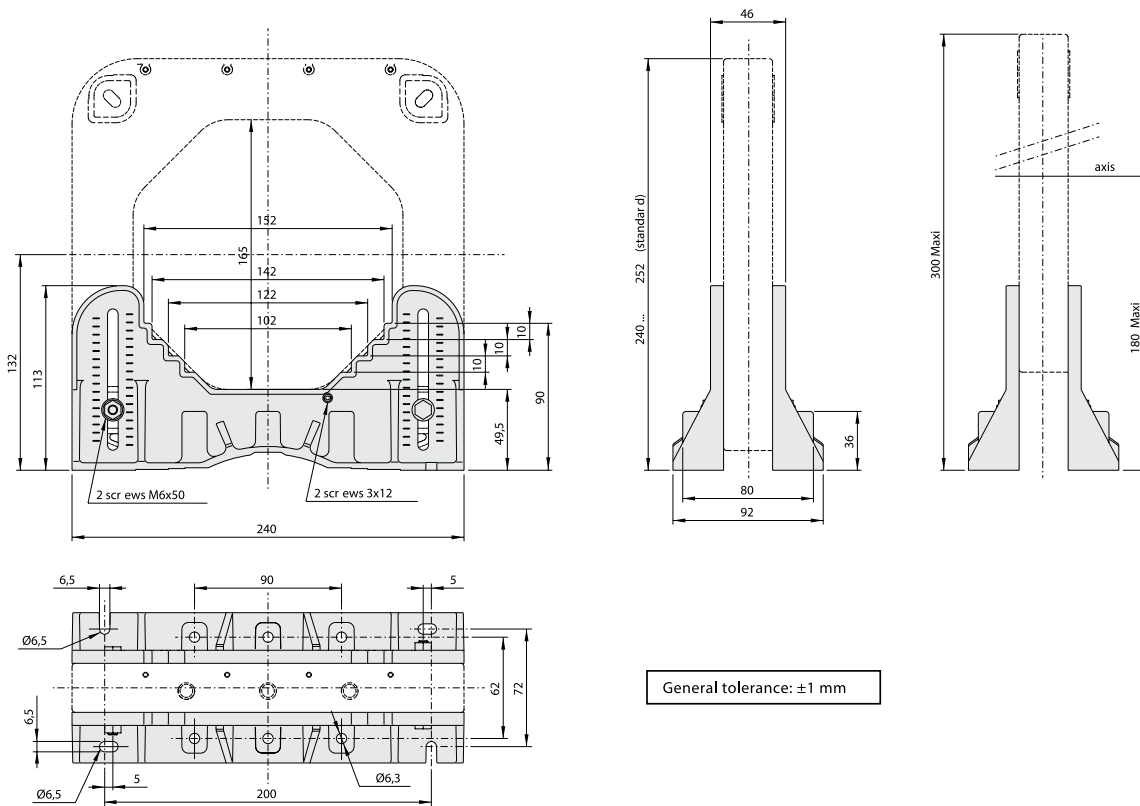

Right angle brackets mounting on NCS165T sensors

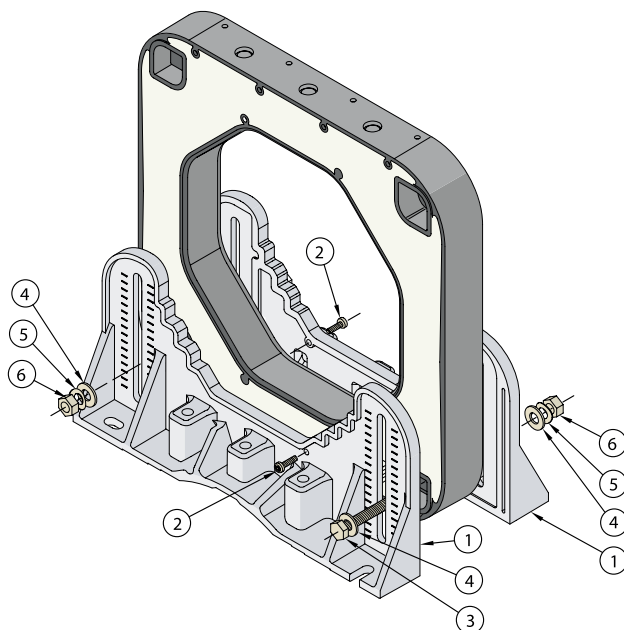

- 1 - Side plate: x2
- 2 - Standard positioning screw: x2 (3x12)
- 3 - Side plate screw M6: x2 (6x50)
- 4 - Flat washer: x4
- 5 - Spring washer: x2
- 6 - Locknut: x2
- 7 - Not used:
 - Side plate screw M6: x4 (6x30)
 - Flat washer: x4
 - Spring washer: x2
 - Locknut: x2

NCS165T railway current sensors

For infrastructure only

Dimensions and arrangement of right angle brackets (mm)

3

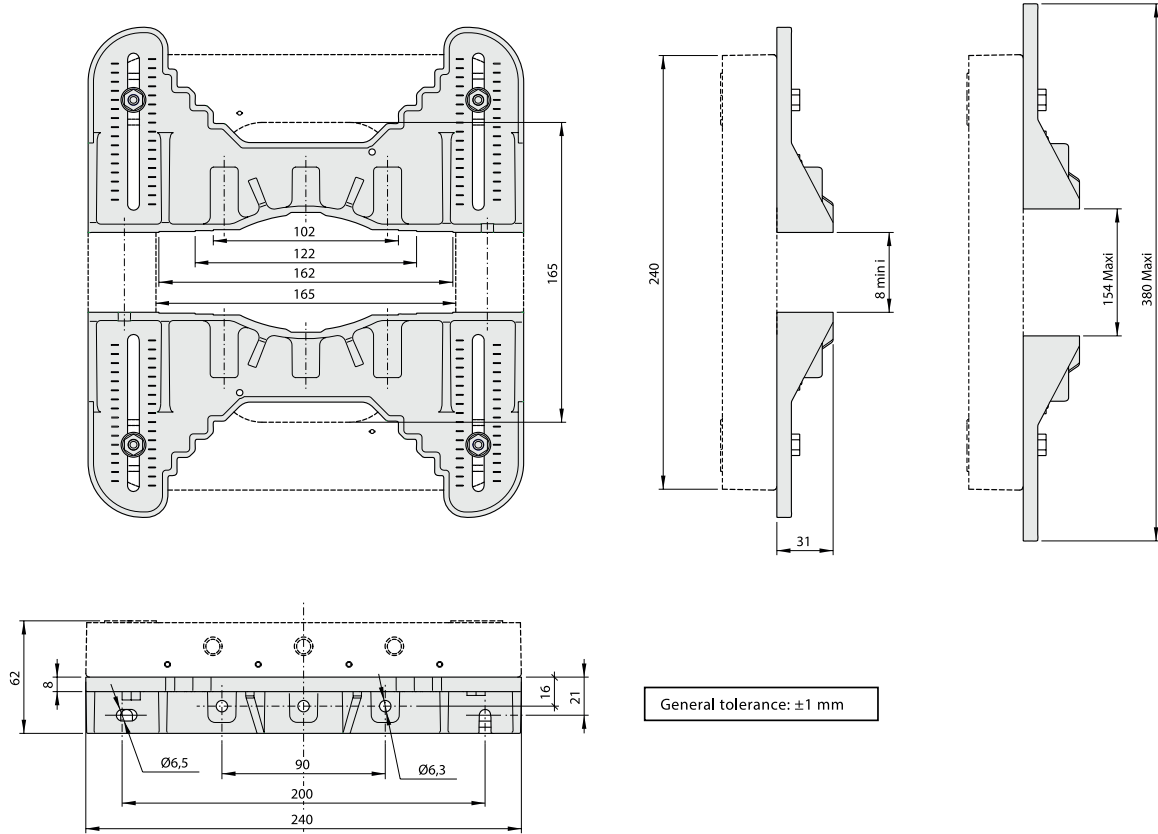

Right angle brackets mounting on NCS165T sensors

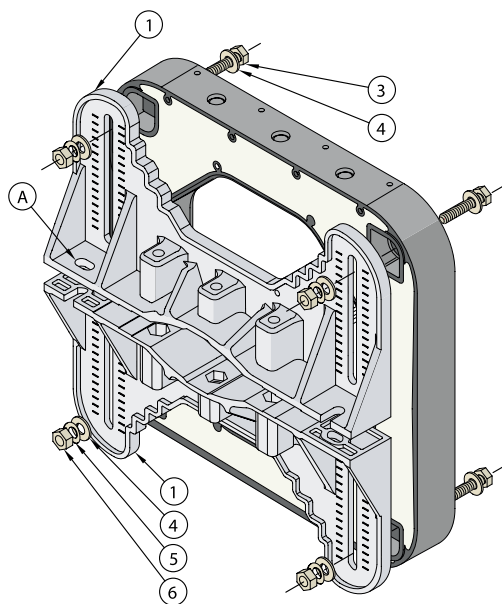

- 1 - Side plate: x2
- 3 - Side plate screw M6: x4 (6x30)
- 4 - Flat washer: x8
- 5 - Spring washer: x4
- 6 - Locknut: x4
- 7 - Not used:
 - Side plate screw M6: x4 (6x50)
 - Standard positioning screw: x2 (3x12)

A - The screws for clamping the side plates to the bar (or cable) are not supplied

NCS165T railway current sensors

For infrastructure only

Dimensions and arrangement of right angle brackets (mm)

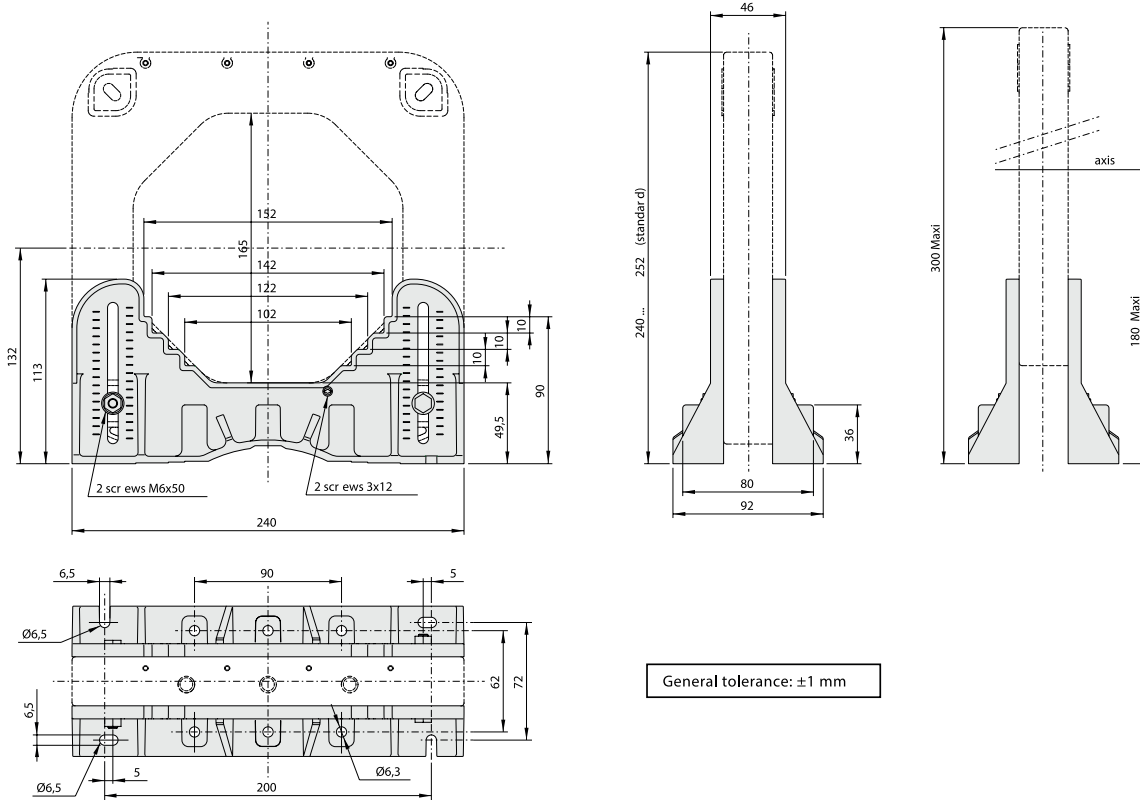

Right angle brackets mounting on NCS165T sensors

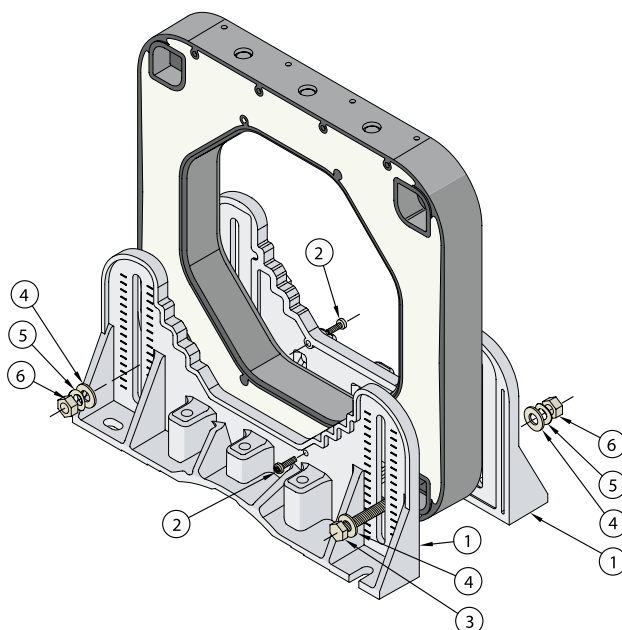

- 1 - Side plate: x2
- 2 - Standard positioning screw: x2 (3x12)
- 3 - Side plate screw M6: x2 (6x50)
- 4 - Flat washer: x4
- 5 - Spring washer: x2
- 6 - Locknut: x2
- 7 - Not used:
 - Side plate screw M6: x4 (6x30)
 - Flat washer: x4
 - Spring washer: x2
 - Locknut: x2

Railway voltage sensors VS range

Electronic technology for rolling stock and infrastructure

3

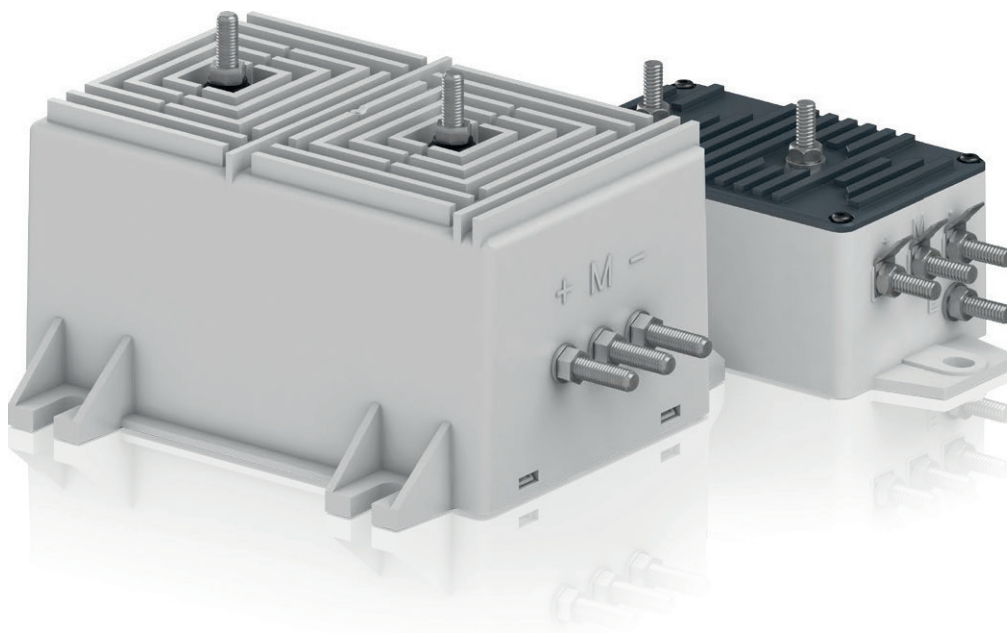

100% electronic a great leap forward

To push the performance barriers back ever further, VS sensors are made 100% electronic. Our sensors are the first ones on the market to incorporate this innovation. They prove themselves every day and give their users the edge in a broad range of applications. This guarantees you unbeatable dynamic performances that give optimal slaving of customer equipment while complying with the latest standards in force.

VS sensors are perfect for use in sectors such as railways, mining and control in hazardous environments.

VS voltage sensors and CS current sensors together constitute an offer the railway industry cannot afford to ignore.



Incomparable protection against magnetic fields

VS sensors are conceived, designed and renowned for their unrivalled immunity to ambient magnetic fields. Although they are in continuous proximity of powerful currents capable of distorting their measurements, this does not, in fact, occur. Their accuracy is rock-solid and once set to measure a particular voltage, that is what they measure – that and nothing else.

Perfect efficiency in every environment

The VS range has been designed for applications in difficult environments such as on-board railway equipment (power converters, auxiliary converters for heating, ventilation and air conditioning) and the mining industry. Their robust design and excellent performances (e.g. operating range between -40° and $+85^{\circ}\text{C}$) make VS voltage sensors ideal for use in other very demanding applications (marine, wind-power, ozone generators, etc.).

Going beyond ordinary standards

PETERCEM have been ISO 9001 certified since 1993 and our sensors bear the CE label. This ongoing striving after quality has always been the hallmark of a company where excellence and safety are part of the culture, from design right through to production.

This culture is the result of continuous research to make technical progress and meet our customers' demands.

The chief selling-point of VS sensors is their quality. Compliance with EN 50121-X for electromagnetic disturbance and EN 50155 for their high-tech electronic design is proof of their ability to comply with the most detailed constraints as well as major demands. The fact that each individual sensor is subjected to rigorous testing such as sensor burn-in is proof of the importance PETERCEM attribute to quality.

VS sensors meet the various security standards in force such as EN 50124-1 for electrical insulation and NFF 16101-NFF 16102 for fire-smoke resistance.

Environment-friendly

PETERCEM have long been concerned with the protection of the environment, as proved by the ISO 14001 certification they received in 1998. This environmental approach is particularly noticeable in production of the VS range in the reduction of the number of components, in the use of a low-energy manufacturing procedure and the use of recyclable packing.

The products in use are also characterized by their reduced energy consumption.

Quality that goes beyond standards

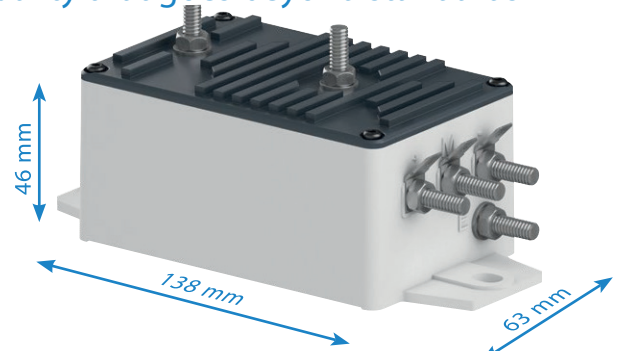

PETERCEM have applied the notion "Small is beautiful" to its products.

By integrating the notion of reduced size into their VS sensors, PETERCEM have brought miniaturization to a point of perfection.

This miniaturization gives great flexibility of installation. The great breakthrough with VS sensors is that they are 100% electronic. This makes it possible to put cutting-edge technology into the smallest possible space. Everything is integrated; in other words everything is inside to leave as much room as possible outside.

Optimized electronic performance

The electrical performances of VS sensors are genuinely customized to a variety of demands and meet the severest constraints. VS sensors give the best accuracy and performance for money on the market. And their performances really come up to your expectations.

Flexibility of use

All our products have been conceived and designed so that installation and use are as simple as possible. Flexibility of installation and operation obtained using a range of connector variants mean that VS sensors are very easy to use. In fact, high-tech sensors have never been as easy to use.



EM010 ... EM020 railway voltage sensors

For rolling stock and infrastructure

600 to 5000 V - Closed loop technology

3

Closed loop Hall effect technology

Closed loop Hall effect technology also allows for voltage measurement.

For calibrated EM010 sensors, the voltage to be measured is applied directly to the primary terminals of the sensor.



EM10

Ordering details

Nominal primary voltage U_{PN} V r.m.s.	Secondary current at U_{PN} mA	Supply voltage V DC	Secondary connection	Type	Order code
600	50	$\pm 12 \dots \pm 24$	5 x M5 studs	EM010-9239	EM010-9239
750	50	$\pm 12 \dots \pm 24$	5 x M5 studs	EM010-9240	EM010-9240
1000	50	$\pm 12 \dots \pm 24$	5 x M5 studs	EM010-9371	EM010-9371
1500	50	$\pm 12 \dots \pm 24$	5 x M5 studs	EM010-9317	EM010-9317
2000	50	$\pm 12 \dots \pm 24$	5 x M5 studs	EM020-9318	1SBT182020R9318
3000	50	$\pm 12 \dots \pm 24$	5 x M5 studs	EM020-9319	1SBT183020R9319
4200	50	$\pm 12 \dots \pm 24$	5 x M5 studs	EM010-9394	EM010-9394
5000	50	$\pm 12 \dots \pm 24$	5 x M5 studs	EM010-9354	EM010-9354

Note: technical data available on request.

VS50B ... VS4200B railway voltage sensors

For rolling stock and infrastructure
50 to 4200 V - Electronic technology

Electronic technology

These voltage sensors use the new PETERCEM 100 % electronic technology (the magnetic circuit and Hall probe are no longer required). The voltage to be measured is applied directly to the primary terminals of the sensor. They are specially designed and manufactured to meet the latest railway standards.

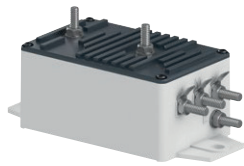

VS50B to VS1500B

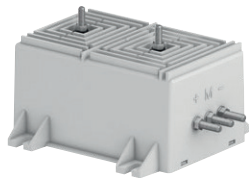

VS2000B to VS4200B

Ordering details

Nominal primary voltage V r.m.s.	Secondary current at U _{PN} mA	Supply voltage VDC	Secondary connection	Type	Order code
50	50	±12 ... ±24	4 x M5 studs // 3 x 6.35 x 0.8 Faston	VS50B	1SBT160050R0001
125	50	±12 ... ±24	4 x M5 studs // 3 x 6.35 x 0.8 Faston	VS125B	1SBT160125R0001
250	50	±12 ... ±24	4 x M5 studs // 3 x 6.35 x 0.8 Faston	VS250B	1SBT160250R0001
500	50	±12 ... ±24	4 x M5 studs // 3 x 6.35 x 0.8 Faston	VS500B	1SBT160500R0001
750	50	±12 ... ±24	4 x M5 studs // 3 x 6.35 x 0.8 Faston	VS750B	1SBT160750R0001
1000	50	±12 ... ±24	4 x M5 studs // 3 x 6.35 x 0.8 Faston	VS1000B	1SBT161000R0001
1500	50	±12 ... ±24	4 x M5 studs // 3 x 6.35 x 0.8 Faston	VS1500B	1SBT161500R0001
2000	50	±12 ... ±24	3 x M5 studs	VS2000B	1SBT162000R0001
3000	50	±12 ... ±24	3 x M5 studs	VS3000B	1SBT163000R0001
4000	50	±12 ... ±24	3 x M5 studs	VS4000B	1SBT164000R0001
4200	50	±12 ... ±24	3 x M5 studs	VS4200B	1SBT164200R0001

VS50B ... VS1500B railway voltage sensors

For rolling stock and infrastructure

Technical data

3

Utilisation

Electronic sensors to measure DC, AC or pulsating voltages with insulation between primary and secondary circuits.

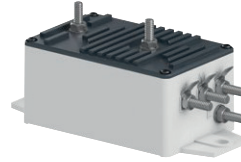

			VS50B	VS125B	VS250B	VS500B
Nominal primary voltage		V r.m.s.	50	125	250	500
Measuring range	@ ±12 V (±5%) / 1 min/h	V peak	±75	±187.5	±375	±750
Measuring range	@ ±24 V (±5%) / 1 min/h	V peak	±75	±187.5	±375	±750
Not measurable overload	1 sec/hour	V peak	150	375	750	1500
Max. measuring resistance	@ U _{PMAX} & ±12 V (±5%)	Ω	67	67	67	67
Max. measuring resistance	@ U _{PMAX} & ±24 V (±5%)	Ω	188	188	188	188
Min. measuring resistance	@ U _{PN} & ±24 V (±5%)	Ω	0	0	0	0
Secondary current at U _{PN}		mA	50	50	50	50
Accuracy at U _{PN}	@ +25 °C	%	≤±0.9	≤±0.9	≤±0.9	≤±0.9
Accuracy at U _{PN}	-25 ... +70 °C	%	≤±1.5	≤±1.5	≤±1.5	≤±1.5
Accuracy at U _{PN}	-40 ... +85 °C	%	≤±1.7	≤±1.7	≤±1.7	≤±1.7
Offset current	@ +25 °C & ±24 V (±5%)	mA	≤±0.15	≤±0.15	≤±0.15	≤±0.15
Linearity	0.1U _{PN} ... 1.5U _{PN}	%	≤0.3	≤0.3	≤0.3	≤0.3
Delay time		μs	≤10	≤10	≤10	≤10
dv/dt correctly followed		V / μs	≤0.6	≤1.5	≤3	≤6
Bandwidth	-3 dB & R _M = 50 Ω	kHz	≤13	≤13	≤13	≤13
Max. no-load consumption current	@ ±24 V (±5%)	mA	≤50	≤50	≤50	≤50
Dielectric strength Primary/(Secondary+Screen)	50 Hz, 1 min	kV	3.3	3.3	3.3	3.3
Dielectric strength Secondary/Screen	50 Hz, 1 min	kV	0.5	0.5	0.5	0.5
Partial discharges : extinction voltage	@ 10pC, 50 Hz	kV	≥1.1	≥1.1	≥1.1	≥1.1
Supply voltage	±5%	V DC	±12 ... ±24	±12 ... ±24	±12 ... ±24	±12 ... ±24
Mass		kg	0.333	0.333	0.333	0.333
Operating temperature		°C	-40 ... +85	-40 ... +85	-40 ... +85	-40 ... +85
Storage temperature		°C	-50 ... +90	-50 ... +90	-50 ... +90	-50 ... +90

Max. common mode voltage

The following two conditions must be continuously and simultaneously respected:

- 1) $U_{HT+} + U_{HT-} \leq 4.2 \text{ kV peak}$
and
- 2) $|U_{HT+} - U_{HT-}| \leq U_{PMAX}$

General data

- Coated electronic circuit.
- Plastic case and insulating resin are self-extinguishing.
- Direction of the current: A positive primary differential voltage ($U_{HT+} - U_{HT-} > 0$) results in a positive secondary output current from terminal M.
- Protections:
 - of the measuring circuit against short-circuits.
 - of the measuring circuit against opening.
 - of the power supply against polarity reversal.
- Burn-in test in accordance with FPTC 404304 cycle.
- Tightening torque for M5 terminal studs (N.m): 2 N.m.

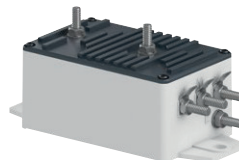

			VS750B	VS1000B	VS1500B
Nominal primary voltage		V r.m.s.	750	1000	1500
Measuring range	@ ±12 V (±5%) / 1 min/h	V peak	±1125	±1500	±2250
Measuring range	@ ±24 V (±5%) / 1 min/h	V peak	±1125	±1500	±2250
Not measurable overload	1 sec/hour	V peak	2250	3000	4500
Max. measuring resistance	@ U _{PMAX} & ±12 V (±5%)	Ω	67	67	67
Max. measuring resistance	@ U _{PMAX} & ±24 V (±5%)	Ω	188	188	188
Min. measuring resistance	@ U _{PN} & ±24 V (±5%)	Ω	0	0	0
Secondary current at U _{PN}		mA	50	50	50
Accuracy at U _{PN}	@ +25 °C	%	≤±0.9	≤±0.9	≤±0.9
Accuracy at U _{PN}	-25 ... +70 °C	%	≤±1.5	≤±1.5	≤±1.5
Accuracy at U _{PN}	-40 ... +85 °C	%	≤±1.7	≤±1.7	≤±1.7
Offset current	@ +25 °C & ±24 V (±5%)	mA	≤±0.15	≤±0.15	≤±0.15
Linearity	0.1U _{PN} ... 1.5U _{PN}	%	≤0.3	≤0.3	≤0.3
Delay time		μs	≤10	≤10	≤10
dv/dt correctly followed		V/μs	≤9	≤12	≤18
Bandwidth	-3 dB & R _M = 50 Ω	kHz	≤13	≤13	≤13
Max. no-load consumption current	@ ±24 V (±5%)	mA	≤50	≤50	≤50
Dielectric strength Primary/(Secondary+Screen)	50 Hz, 1 min	kV	4.3	5.5	6.5
Dielectric strength Secondary/Screen	50 Hz, 1 min	kV	0.5	0.5	0.5
Partial discharges : extinction voltage	@10pC, 50 Hz	kV	≥1.1	≥2.2	≥2.2
Supply voltage	±5%	VDC	±12 ... ±24	±12 ... ±24	±12 ... ±24
Mass		kg	0.333	0.333	0.333
Operating temperature		°C	-40 ... +85	-40 ... +85	-40 ... +85
Storage temperature		°C	-50 ... +90	-50 ... +90	-50 ... +90

Primary connection

— 2 M5 studs

Standard secondary connections

— 4 M5 studs and 3 Faston 6.35 x 0.8

Options

— Primary connection: 2 separated High Voltage cables.
— Secondary connection: Shielded cable (2 m), M5 inserts, Lemo connector.

Conformity

EN 50155
EN 50121-3-2
EN 50124-1



VS2000B ... VS4200B railway voltage sensors

For rolling stock and infrastructure

Technical data

3

Utilisation

Electronic sensors to measure DC, AC or pulsating voltages with insulation between primary and secondary circuits.

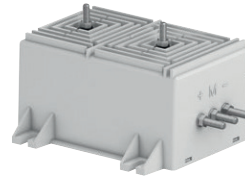

			VS2000B	VS3000B	VS4000B	VS4200B
Nominal primary voltage		V r.m.s.	2000	3000	4000	4200
Measuring range	@ ±12 V (±5%) / 1 min/h	V peak	±3000	±4500	±6000	±6000
Measuring range	@ ±24 V (±5%) / 1 min/h	V peak	±3000	±4500	±6000	±6000
Not measurable overload	1 sec/hour	V peak	6000	9000	12000	12000
Max. measuring resistance	@ U _{PMAX} & ±12 V (±5%)	Ω	61	61	61	61
Max. measuring resistance	@ U _{PMAX} & ±24 V (±5%)	Ω	183	183	183	183
Min. measuring resistance	@ U _{PN} & ±24 V (±5%)	Ω	0	0	0	0
Secondary current at U _{PN}		mA	50	50	50	50
Accuracy at U _{PN}	@ +25 °C	%	≤±0.9	≤±0.9	≤±0.9	≤±0.9
Accuracy at U _{PN}	-25 ... +70 °C	%	≤±1.5	≤±1.5	≤±1.5	≤±1.5
Accuracy at U _{PN}	-40 ... +85 °C	%	≤±1.7	≤±1.7	≤±1.7	≤±1.7
Offset current	@ +25 °C & ±24 V (±5%)	mA	≤±0.15	≤±0.15	≤±0.15	≤±0.15
Linearity	0.1U _{PN} ... 1.5U _{PN}	%	≤0.3	≤0.3	≤0.3	≤0.3
Delay time		μs	≤10	≤10	≤10	≤10
dv/dt correctly followed		V / μs	≤24	≤36	≤48	≤50
Bandwidth	-3 dB & R _M = 50 Ω	kHz	≤13	≤13	≤13	≤13
Max. no-load consumption current	@ ±24 V (±5%)	mA	≤50	≤50	≤50	≤50
Dielectric strength	50 Hz, 1 min	kV	8	12	12	12
Primary/Secondary						
Partial discharges : extinction voltage	@10pC, 50 Hz	kV	≥4.3	≥4.3	≥4.3	≥4.3
Supply voltage	±5%	V DC	±12 ... ±24	±12 ... ±24	±12 ... ±24	±12 ... ±24
Mass		kg	1.5	1.5	1.5	1.5
Operating temperature		°C	-40 ... +85	-40 ... +85	-40 ... +85	-40 ... +85
Storage temperature		°C	-50 ... +90	-50 ... +90	-50 ... +90	-50 ... +90

Max. common mode voltage

The following two conditions must be continuously and simultaneously respected:

- 1) $U_{HT+} + U_{HT-} \leq 10 \text{ kV peak}$
and
- 2) $|U_{HT+} - U_{HT-}| \leq U_{PMAX}$

General data

- Coated electronic circuit.
- Plastic case and insulating resin are self-extinguishing.
- Direction of the current: A positive primary differential voltage ($U_{HT+} - U_{HT-} > 0$) results in a positive secondary output current from terminal M.
- Protections :
 - of the measuring circuit against short-circuits.
 - of the measuring circuit against opening.
 - of the power supply against polarity reversal.
- Burn-in test in accordance with FPTC 404304 cycle.
- Tightening torque for M5 terminal studs (N.m): 2 N.m.

Primary connection

— 2 M5 studs

Standard secondary connection

— 3 M5 studs

Options

- Primary connection: 2 separated High Voltage cables.
- Secondary connection: shielded cable (2 m), M5 inserts, Lemo connector.
- Nominal secondary current I_{SN} :
 I_{SN} (for U_{PN}) = 20 mA or I_{SN} (for U_{PN}) = 80 mA.

Conformity

EN 50155
EN 50121-3-2
EN 50124-1



VS railway voltage sensors

For rolling stock and infrastructure

Dimensions (mm)

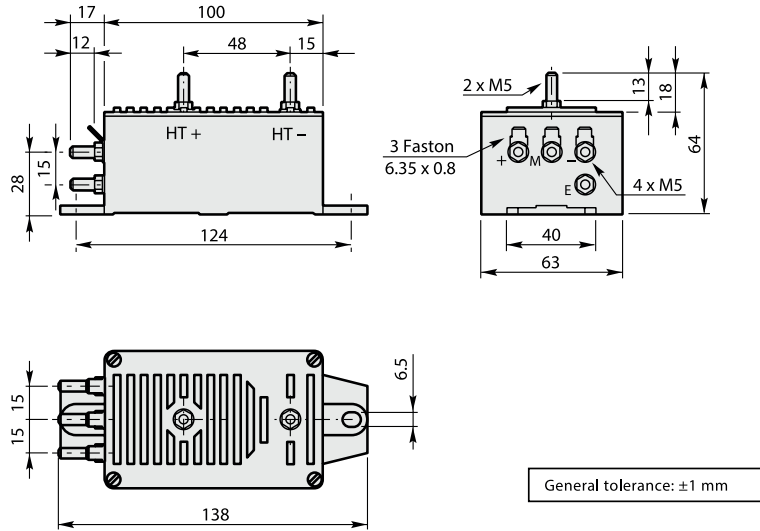

General tolerance: ±1 mm

Size 0 (VS50B to VS1500B)

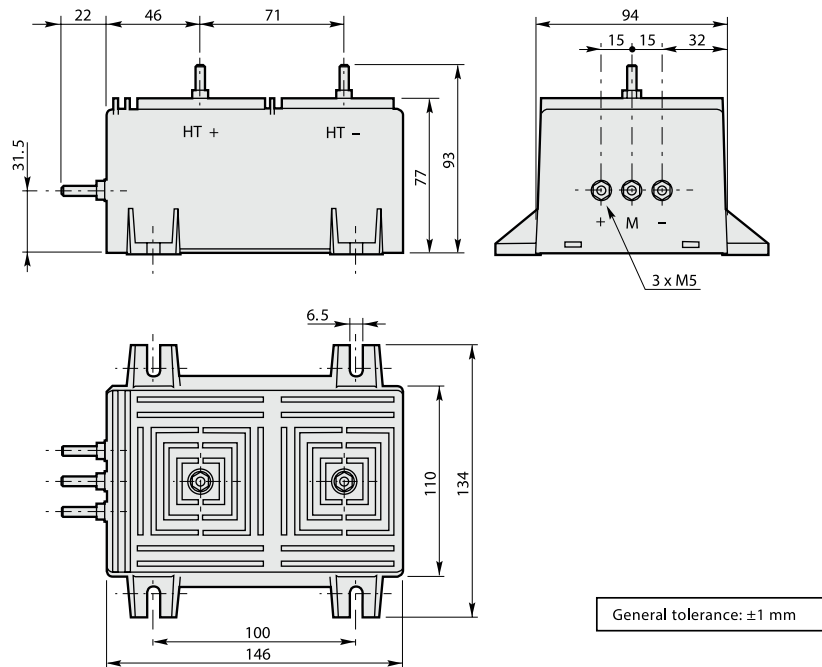

General tolerance: ±1 mm

Size 1 (VS2000B to VS4200B)

Railway voltage detectors VD range

Electronic technology for rolling stock and infrastructure

3

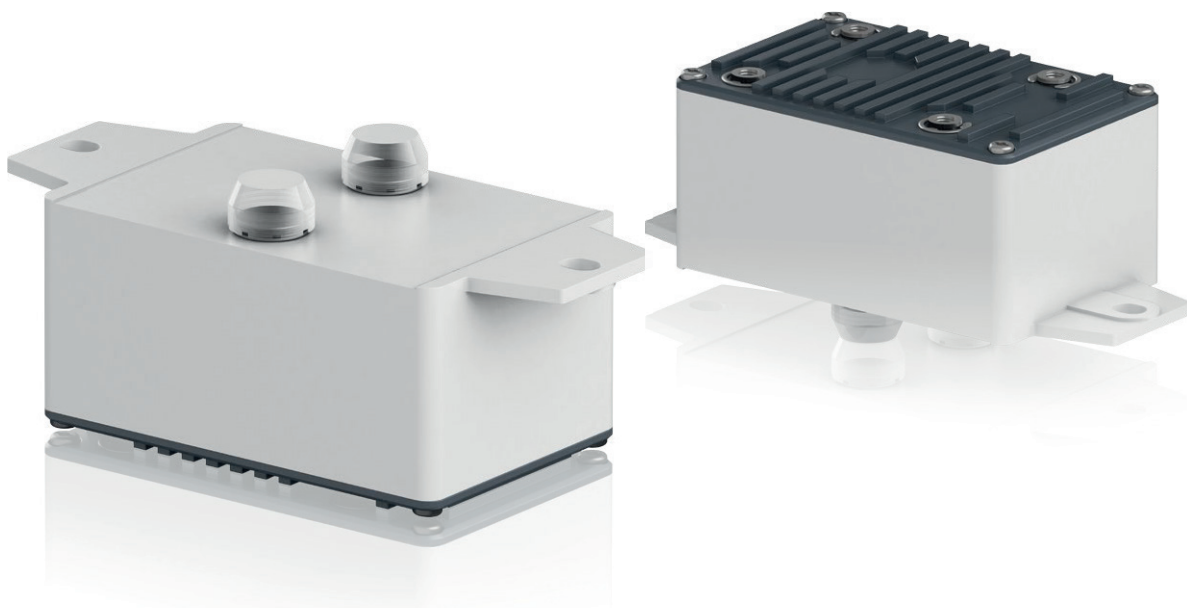

Maintenance personnel warning: an PETERCEM innovation.

Faced with a current offering with insufficient reliability that doesn't meet the market standards, PETERCEM has innovated with the VD Railway voltage detector. This 100% electronic product allows your maintenance operatives to be aware of the presence of a continuous voltage, before carrying out operations on equipment. When the diode flashes, the voltage is greater than 50 V and when it is extinguished, the voltage is

below this limit. Provided with a double internal function and independent LEDs, the VD Railway voltage detector offers redundant function and a lifetime greater than 1 million hours. Guaranteed for 2 years, it allows reliable decisions to carry out operations to be made and warns personnel from dangerous high voltages.



An answer adapted to market requirements

Guaranteeing optimum reliability, the VD Railway voltage detector meets the requirements for difficult environments and is adaptable to the most demanding applications such as:

- rolling stock: main converters, auxiliary converters. Based on the SNCF CF60-100 specification, the whole French railway market imposes the presence of a voltage detector within built redundancy, to meet the drastic requirements of this sector.
- electronic power systems integrating capacitors banks: backups, wind generators, variable speed drives, electrolysis require voltage detectors of robust design and offer high reliability.

A considered and measured integrated design

Thanks to a 100% electronic technology, PETERCEM has reduced the size of the VD Railway voltage sensor to a minimum. The ultra-compact dimensions allow for simplified installation. Additionally, its self-sufficiency in energy means that it can work without an external power supply.

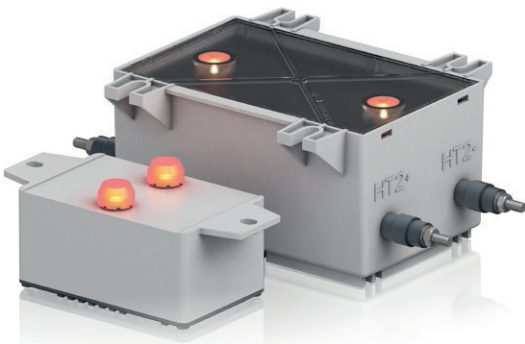

Quality that goes beyond standards

The new product complies with the standard EN 50155 (high technology electronic design and testing) and EMC EN 50121-3-2 (electromagnetic compatibility: resistance to electromagnetic interference) and follows a very rigorous manufacturing process.

Certified ISO 9001 and CE labeled, the VD Railway voltage detector complies with the most rigorous standards and requirements.

The VD Railway voltage detector is the only product on the market that complies with rolling stock security standards such as: EN 50124-1 (electrical isolation), EN 50163 (standardized voltage 1500 V DC).

Because your security is essential

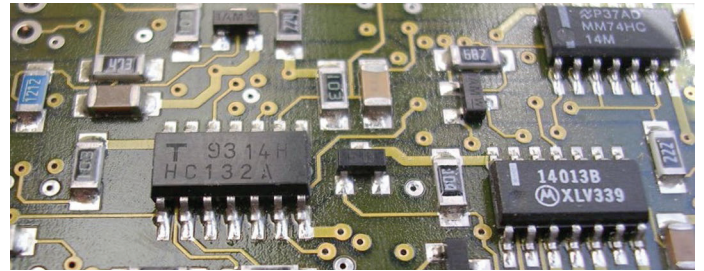
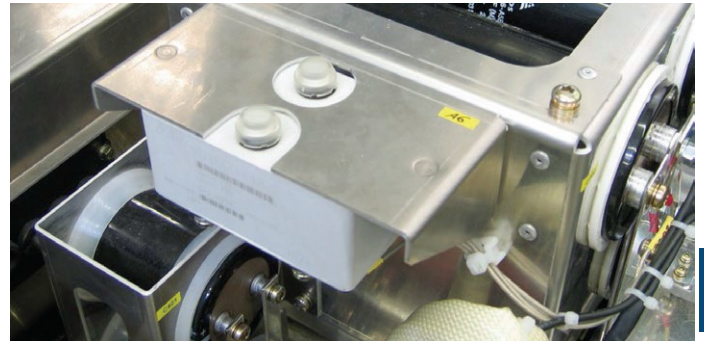

100% electronic

At the forefront of technological innovation at PETERCEM, the VD Railway voltage detector is 100% electronic. Other than the assurance of providing unbeatable performance, it has reduced dimensions:

smaller and more compact, it offers greater installation flexibility. Its 100% electronic technology also provides it with an excellent immunity to surrounding magnetic fields: a guarantee for accurate detection of a given voltage.

Double lifetime to avoid taking any risks

The VD Railway voltage detector is a voltage detection system with built in redundancy. It is equipped with two electronic circuits each connected to a light emitting diode (LED). These two parallel and independent systems guarantee a high level of functioning and improve the reliability of the detector.

Double lifetime to avoid taking any risks

Reduction of the number of components, low energy manufacturing processes, use of recyclable packing, reduced energy consumption... The VD Railway voltage detector complies with all the requirements of the ISO 14001 environmental standard, in place at PETERCEM since 1998.



VD1500, VD3000 railway voltage detectors

For rolling stock and infrastructure

Technical data

3

Utilisation

Electronic detectors for direct voltages. This device signals the presence of dangerous voltages via the independent flashing of two LEDs (Light emitting diodes). A secondary supply voltage is not necessary.

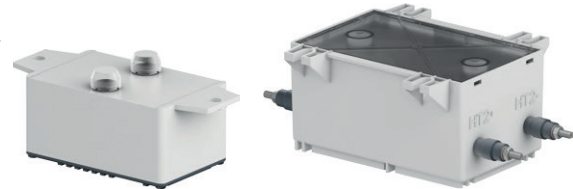

	VD1500-48	VD3000-25
Order code	1SBT900000R0007	1SBT903000R2501
Nominal voltage (U_N)	V DC 1500	3000
Maximum voltage permanent U_{MAX1}	V DC 1800	3600
Maximum voltage long duration U_{MAX2}	5 min V DC 1950	3900
Maximum voltage overload	20 msec/h V DC 2540	4200
Insulation voltage rating (1) (U_{NM})	50 Hz, 1 min kV 6.5	12
Average current consumption (LED flashing)	mA ≤ 1.5	≤ 1.5
LED flashing frequency	Hz 2	2
Activating voltage (U_{ON})	V DC > 49	> 25.5
Activating voltage (U_{OFF})	V DC < 38	< 16.5
Mass	kg ≤ 0.5	≤ 1.5
Starting temperature	$^{\circ}\text{C}$ -40 ... +70	-40 ... +70
Operating temperature	$^{\circ}\text{C}$ -25 ... +70	-25 ... +70
Storage temperature	$^{\circ}\text{C}$ -40 ... +85	-40 ... +85
Light Emitting Diode (LED) colour	red	red
Light Emitting Diode (LED) angle of vision	$\geq 15^{\circ}$	$\geq 15^{\circ}$

(1) Defined acc. to overload category: 3 (OV3), pollution degree: 2 (PD2)

General data

- Plastic case and insulating resin are self-extinguishing.
- The casing temperature must not exceed 105 °C.
- Fixing holes in the case moulding for horizontal mounting.
- Product mounting according to the document: *VD range Mounting Instructions*.

— Product Use and Maintenance instructions according to the document: *Use of the Voltage Detector - Preventive and Curative Maintenance VD range*.

- Tightening torque: 2 Nm.

Security

Only qualified and authorised personnel may carry out any operation on the detector; without voltage applied to the terminals of the voltage detector and with the equipment (power converter) electrically isolated.

Primary connection

- Insert M5x7 for terminals.

General operation

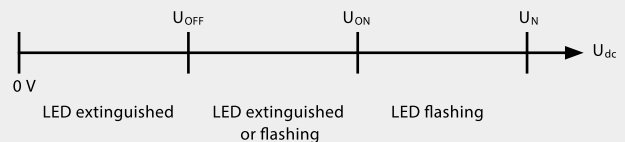

U_{OFF} : Low limit at which the LEDs extinguish when the equipment is electrically isolated.

U_{ON} : High limit at which the LEDs illuminate (flashing frequency approximately 2 Hz) when the equipment power is switched on.

Between these two limits the LEDs maybe extinguished or flashing.

Conformity

EN 50155, EN 50124-1, EN 50121-3-2, EN 50163

VD railway voltage detectors

For rolling stock and infrastructure

Dimensions (mm)

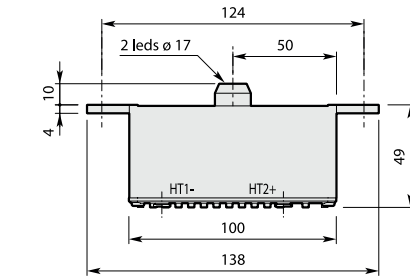
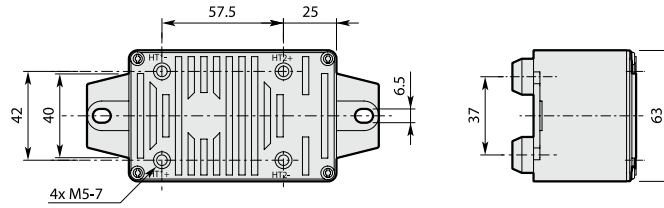

VD1500-48

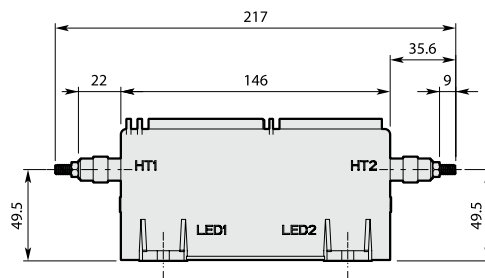
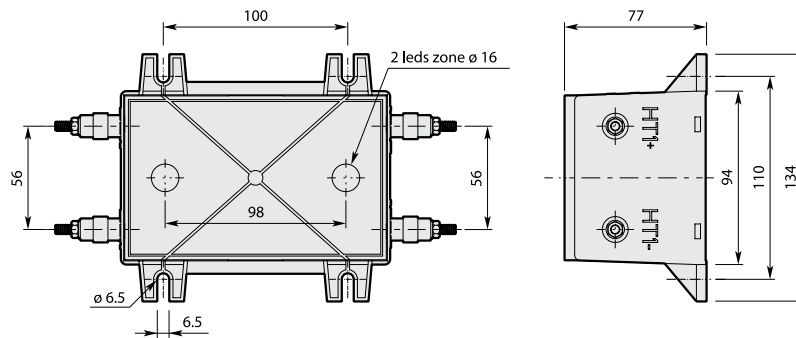

General tolerance: ± 1 mm

VD3000-25

Wiring diagram

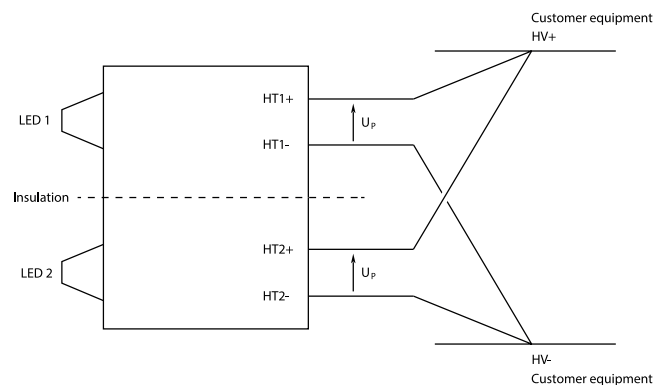



Dimensions	90
Closed loop Hall effect current sensors	
Instructions for mounting and wiring ES, MP, EL and CS sensors	92
Electronic current sensors	
Instructions for mounting and wiring NCS sensors	93
Open loop Hall effect current sensors	
Instructions for mounting and wiring HBO sensors	96
Electronic voltage sensors	
Instructions for mounting and wiring VS sensors	97
Electronic voltage sensors	
Instructions for mounting and wiring VD detectors	99
Calculation guide	
Closed loop Hall effect current sensors - ES, CS, MP and EL sensors	101
Electronic technology current sensors NCS sensors	104
Electronic technology voltage sensors VS sensors	105

Glossary

Description of the main current and voltage sensor's characteristics

4

Nominal primary current (I_{PN}) and nominal primary voltage (U_{PN})

This is the maximum current or voltage that the sensor can continuously withstand (i.e. without time limit).

The sensor is thermally sized to continuously withstand this value.

For alternating currents, this is the r.m.s. value of the sinusoidal current.

The value given in the catalogue or in the technical data sheet is a nominal rating value. This figure can be higher if certain conditions (temperature, supply voltage...) are less restricting.

Operating range (I_{PN} , U_{PN}) and temperature ($^{\circ}C$)

The sensor has been designed for a certain operating temperature. If this temperature is reduced, then it is possible to use the sensor with a higher thermal current or voltage.

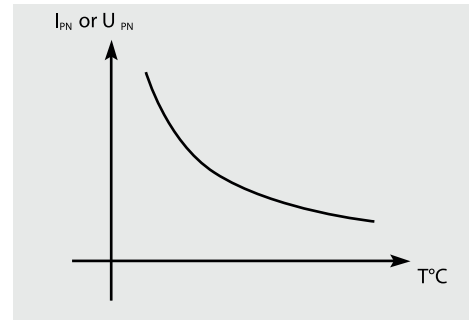

Measuring range ($I_{P_{MAX}}$ and $U_{P_{MAX}}$)

This is the maximum current or voltage that the sensor can measure with the Hall effect. In general, mainly for thermal reasons, the sensor cannot continuously measure this value for direct currents and voltages.

This measuring range is given for specific operating conditions. This can vary depending mainly on the parameters below (see calculation guide).

- Supply voltage

The measuring range increases with the supply voltage.

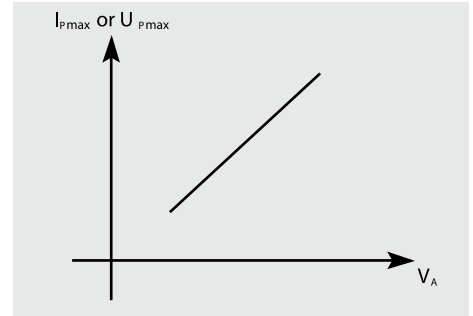

- Measuring resistance

The measuring range increases when the measuring resistance is reduced.

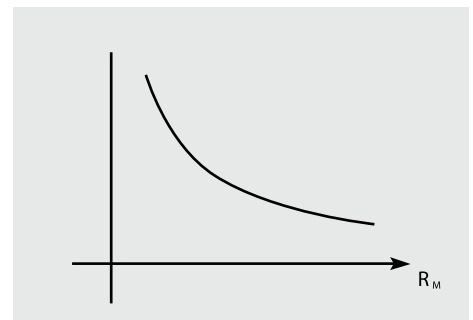

Not measurable overload

This is the maximum instantaneous current or voltage that the sensor can withstand without being destroyed or damaged.

However the sensor is not able to measure this overload value.

This value must be limited in amplitude and duration in order to avoid magnetising the magnetic circuit, overheating or straining the electronic components. A sensor can withstand a lower value overload for longer.

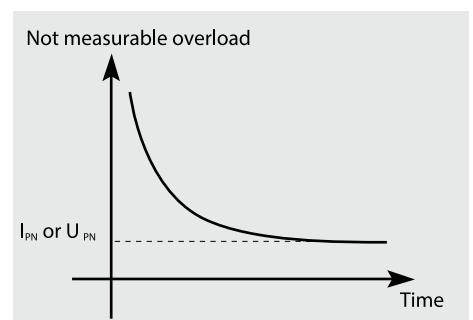

Glossary

Description of the main current and voltage sensor's characteristics

Secondary current I_{SN} at I_{PN} or at U_{PN}

This is the sensor's output current I_S when the input is equal to the nominal primary current I_{PN} or to the nominal primary voltage U_{PN} .

Measuring resistance R_M

This is the resistance connected in the secondary measuring circuit between terminal M of the current or voltage sensor and the 0 V of the supply. The measuring voltage V_M at the terminals of this resistance R_M is proportional to the sensor's secondary current I_S . It is therefore the image of the sensor's primary current I_p or primary voltage U_p .

For thermal reasons, a minimum value is sometimes required in certain operating conditions in order to limit overheating of the sensor.

The maximum value for this resistance is determined by the measuring range.

(see calculation guide and the curve $I_{P_{MAX}}$ or $U_{P_{MAX}} = f(R_M)$ opposite).

Accuracy

This is the maximum error for the sensor output I_{SN} for the nominal input value (current or voltage).

This takes into account the residual current, linearity and thermal drift.

AC accuracy

This is the maximum error for the sensor's output I_{SN} for an alternating sinusoidal primary current with a frequency of 50 Hz.

The residual current is not taken into account. The linearity and thermal drift are always included.

No-load consumption current

This is the sensor's current consumption when the primary current (or primary voltage) is zero.

The total current consumption of the sensor is therefore the no-load consumption current plus the secondary current.

Closed loop Hall effect current sensors

Instructions for mounting and wiring ES, MP, EL and CS sensors

4

Introduction

These instructions are a non-exhaustive synthesis of the main recommendations for mounting closed loop Hall effect current sensors. Each application configuration is different, do not hesitate to contact us for advice adapted to your particular case. Please note that incorrect or non-judicious use of the sensor may lead to deterioration in the performance or operation of the sensor.

1 - Wiring diagram

— Direction of the current: A primary current I_p flowing in the direction of the arrow results in a positive secondary output current I_s from terminal M.

— Supply voltage: bipolar voltage $-V_A \dots 0V \dots +V_A$

Closed loop Hall effect sensors can also operate with a unipolar supply voltage ($-V_A \dots 0V$ or $0V \dots +V_A$) under certain conditions. Please contact your distributor for further details for this application.

1.1 - Sensors without screen terminal

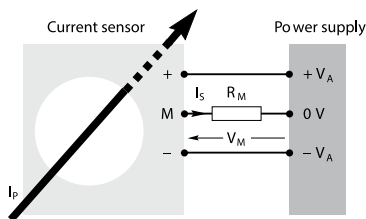

1.2 - Sensors with screen terminal

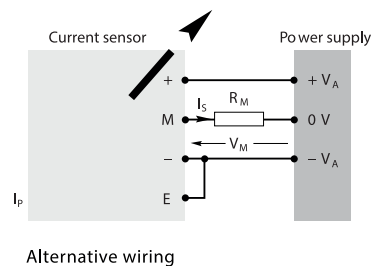
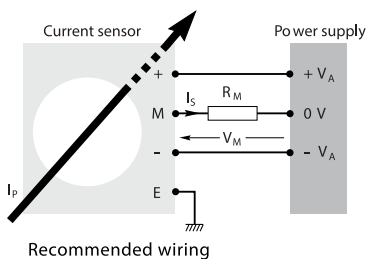

The screen terminal "E" can be connected to the secondary negative terminal (marked "-") on the sensor. However the best EMC performance is obtained by connecting the screen terminal "E" to ground by a copper braid strap as short as possible.

1.3 - Internal electrostatic screen

During very rapid variations in the primary conductor potential compared to the reference potential (high du/dt), a capacitive coupling effect can be produced between the primary conductor and the secondary winding of the sensor. This coupling can lead to measurement errors. In order to eliminate this capacitive coupling, some current sensors have an internal copper electrostatic screen between the secondary winding and the hole for the primary conductor. This screen is linked internally either to an additional terminal marked "E", or to the sensor negative secondary terminal (marked "-").

2 - Mechanical mounting

— All mounting positions are possible: horizontal, vertical, upside down etc.

— Recommended fixing: by screws and flat washers.

— **Installation with a primary bar:** in this case, the sensor must be mechanically fixed, either only by the bar, or only by the enclosure, but never by both at the same time (this type of fixing would lead to mechanical stresses that could lead to deterioration of the sensor casing).

3 - Precautions to be taken into account relative to the electromagnetic environment

Due to their operating principle (measure of magnetic field by the Hall effect probe), closed loop Hall effect current sensors can be sensitive to strong external magnetic fields. It is therefore strongly recommended to avoid positioning them too close to high current power cables. The use of a magnetic screen to protect the sensor may be advised for certain configurations with a strong magnetic influence. The orientation of the sensor is also very important. Please contact your distributor for further information on this subject.

4 - Processing of the sensor's output signal

Standard codes of practice advise that, before the signal is processed, a low-pass filter adapted to the bandwidth of the sensor is used. Moreover, in the case of digital processing of the signal, it is also recommended that the sampling frequency is adapted to the bandwidth of both the signal to be measured and the sensor.

In the event of sensor failure, the processing of the output signal should take into account deterioration in performance (e.g. absence of signal or saturated signal) and rapidly and safely shut the system down.

Electronic current sensors

Instructions for mounting and wiring NCS sensors

Introduction

These instructions are a non-exhaustive synthesis of the main recommendations for mounting electronic current sensors. Each application configuration is different, please do not hesitate to contact us for advice adapted to your particular case. Please note that incorrect or non-judicious use of the sensor may lead to deterioration in the performance or operation of the sensor.

1 - Wiring diagram

Direction of the current:

- **Output current (I_{s1} and I_{s2}):** A primary current flowing in the direction of the arrow results in a positive secondary output current on the terminals I_{s1} and I_{s2} .
- **Output voltage (V_{s1} and V_{s2}):** A primary current flowing in the direction of the arrow results in a positive secondary output voltage on the terminals V_{s1} and V_{s2} .

Supply voltage: bipolar voltage $-V_A \dots 0V \dots +V_A$ ($0 \dots +V_A$ for the NCS305).

It is possible to design electronic current sensors, upon request, that can operate with a unipolar supply voltage ($-V_A \dots 0V$ ou $0V \dots +V_A$).

1.1 Sensors with connector output (current and voltage outputs)

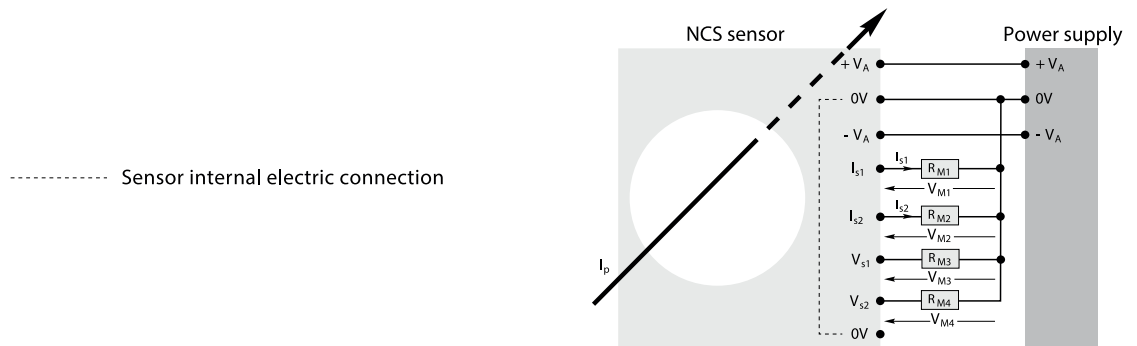

1.2 Sensors with cable output (current outputs)

NCS sensors have two current outputs as standard:

- I_{s1} that supplies ± 20 mA (peak) at $\pm I_{PN}$ (peak)
- I_{s2} that supplies ± 20 mA (peak) at $\pm I_{P_{MAX}}$ (peak)

Two measured gains are thus available.

In the case of a current output, R_M is determined in the following manner:

$$R_M = V_M / I_s \text{ where } V_M = \text{to be obtained at the terminals of } R_M$$

$$I_s = I_{s1} \text{ or } I_{s2} \text{ (current output)}$$

Limitation: $0 \Omega < R_M < 350 \Omega$ for I_s max (peak) of ± 20 mA

The secondary cable passes through the white plastic enclosure (included) containing a ferrite core (NCS125 & NCS165), to reduce the interference that could affect the correct functioning of the sensor.

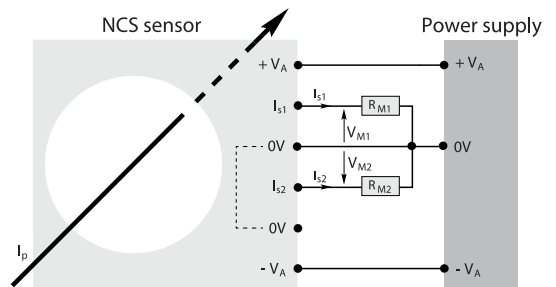

1.3 Sensors with cable output (voltage outputs)

The sensors have two voltage outputs as standard:

- V_{s1} that supplies ± 10 V (peak) at $\pm I_{PN}$ (peak)
- V_{s2} that supplies ± 10 V (peak) at $\pm I_{P_{MAX}}$ (peak)

Two measured gains are thus available.

In the case of a voltage output, R_M is either greater than or equal to 10 k Ω .

The secondary cable passes through the white plastic enclosure (included) containing a ferrite core (NCS125 & NCS165), to reduce the interference that could affect the correct functioning of the sensor.

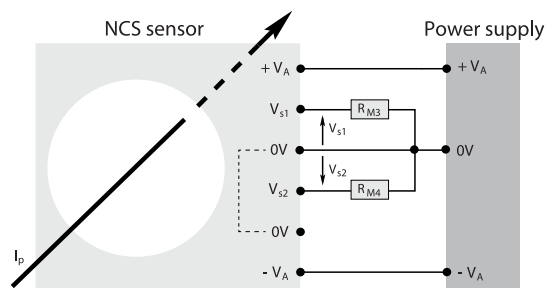

Electronic current sensors

Instructions for mounting and wiring NCS sensors

4

2 - Mechanical mounting

- All mounting positions are possible: horizontal, vertical, upside down etc.
- Recommended fixing: by screws and flat washers. Oblong fixing holes in the enclosure moulding provide a large amount of mounting flexibility and allow for fully symmetrical positioning.
- Fixing by the use of side plate kits:
 - Fixing on one (or several) cable on one (or several) primary bar: in this case, the sensor should only be fixed to the primary conductor mechanically by the side plate kit. The sensor must not be mechanically fixed to the primary conductor by the enclosure and the side plate kit at the same time (this type of mounting would lead to mechanical stresses that may deteriorate the enclosure).
 - Fixing on a chassis or partition: in this case, the side plate kit offers a large amount of mounting flexibility.

See the particular mounting instructions.

Recommendations for the passage of the primary conductor

- The primary conductor may be one (or several) cable or one (or several) bar.
 - In order to obtain the best measuring performance, the primary conductor must be:
 - Centred as much as possible in the opening in the sensor
 - The biggest possible with respect to the opening in the sensor
 - Fixed at an angle close to 90° with respect to a plane formed by the sensor
 - As straight as possible at the sensor in order to minimise local increases in the magnetic field caused by bends in the primary conductor.
- These local increases may create a saturation of one of the sensor probes and induce measurement errors.

For further information, please refer to the "Dimensions" section of the NCS range in this catalogue or to the mounting instructions ref. **1SBC146000M1704** (NCS125 & NCS165) or ref. **1SBC146010M1701** (NCS305).

Electronic current sensors

Instructions for mounting and wiring NCS sensors

3 - Precautions to be taken into account relative to the electromagnetic environment

Due to the continuous reduction in equipment volume and the increase in their power, internal system components are subject to strong electromagnetic interference. NCS sensors, based on the measure of currents by magnetic fields, (see functioning description **1SBD370024R1000**) must not be interfered by surrounding magnetic fields. They have therefore been designed in order to allow accurate measurement without interference.

Different tests carried out on NCS sensors show the rejection of the sensors to this external magnetic interference in relation to the configuration of the predefined bar arrangement.

During type testing, the sensors were subject to 3 types of tests:

- magnetic field circuits: measure the influence of the magnetic fields generated by the primary conductor on the sensor
- interference by an external set of bars: measure the influence of the magnetic fields generated by the other conductors different from the primary conductor on the sensor
- coupling of primary bars: measure the influence of the mechanical mounting of the sensor on a primary conductor

During the different tests and in each configuration, the measured results (accuracy) are recorded whilst varying the following elements:

- distance between the sensor and the interfering current
- rotation of the interfering current around the sensor
- the magnitude of the interfering current
- the current form (DC or AC)
- inclination of the sensor on the primary conductor
- centricity of the sensor on the primary bar
- different primary bar configurations (rectangular simple or double, round and arrangements in "U", "S" or "L" configurations)

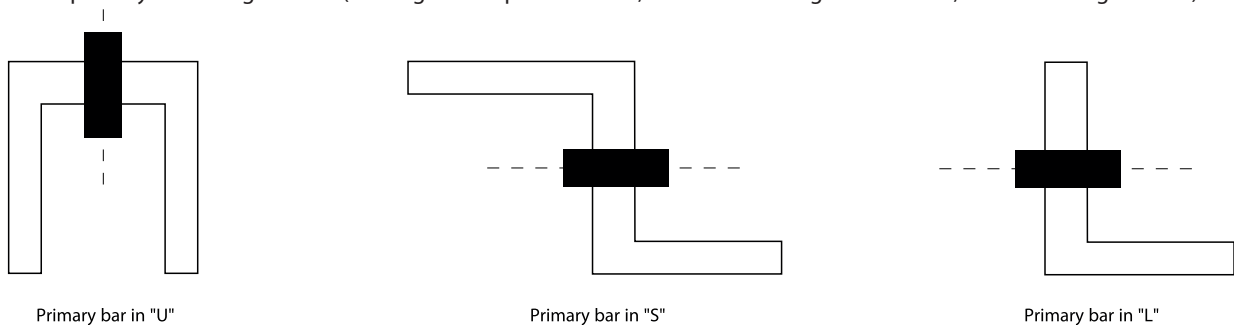

The tests were carried out with the primary bars in "U" configuration, the most restricting condition.

See mounting instructions ref. **1SBC146000M1704** (NCS125 & NCS165) or ref. **1SBC146010M1701** (NCS305) for further information.

3.1 Mounting for improved EMC performance (shielding)

In applications that require the sensor to be used with long cables exposed to interference, it is imperative that shielded cables are used, with the shielding connected to ground at both ends (see figure below).

Standard NCS sensors with cable outputs are supplied in white plastic enclosures containing a ferrite core (NCS125 & NCS165). The secondary cable passes through this white plastic enclosure to reduce the interference caused that could affect the correct functioning of the sensor.

Please contact your distributor for further information on this subject.

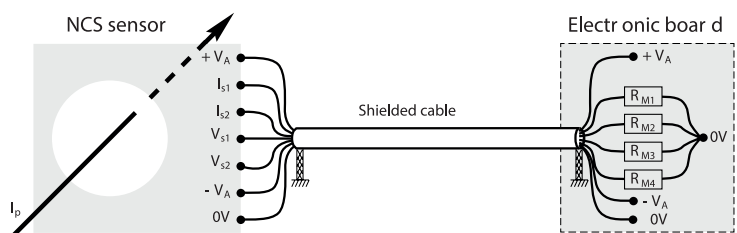

4 - Processing of the sensor's output signal

Standard codes of practice advise that, before the signal is processed, a low-pass filter adapted to the bandwidth of the sensor is used.

Moreover, in the case of digital processing of the signal, it is also recommended that the sampling frequency is adapted to the bandwidth of both the signal to be measured and the sensor.

In the event of sensor failure, the processing of the output signal should take into account this deterioration in performance (e.g. absence of signal or saturated signal) and rapidly and safely shut the system down.

Open loop Hall effect current sensors

Instructions for mounting and wiring HBO sensors

4

Introduction

These instructions are a non-exhaustive synthesis of the main recommendations for mounting open loop Hall effect current sensors. Each application configuration is different, please do not hesitate to contact us for advice adapted to your particular case. Please note that incorrect or non-judicious use of the sensor may lead to deterioration in the performance or operation of the sensor.

1 - Wiring diagram

Direction of the current: a primary current I_p flowing in the direction of the arrow results in a positive secondary output voltage from the terminal VS.

— Supply voltage: bipolar voltage: $-V_A \dots 0V \dots +V_A$

— Contrary to output current devices, HBO sensors do not need a load resistance but it is possible to use one if required.

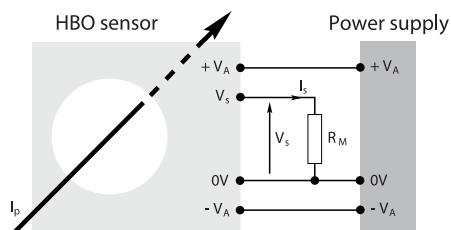

2 - Mechanical mounting

— All mounting positions are possible: horizontal, vertical, upside down etc.

— Recommended fixing: by screws and flat washers.

3 - Precautions to be taken into account relative to the electromagnetic environment

Due to their principle of operation (measure of magnetic field by the Hall effect probe), open loop Hall effect current sensors can be sensitive to strong external magnetic fields. It is therefore strongly recommended to avoid positioning them too close to high current power conductors. The sensor cables (shielded cable recommended) connecting to the equipment should be as short as possible.

These sensors emit almost no electromagnetic radiation but can be sensitive to the effects of external radiation. The sensor is not itself sensitive but the induced voltages, when long cables are used to link the sensor to the connector, can cause interference to the sensor.

In many applications the sensors are mounted in metal housings and have short cable lengths. In these applications, no special precautions are normally required.

In applications that require the sensor is used with long exposed cable lengths, shielded cable must be used, with both ends of the shielding connected to ground (see figure below).

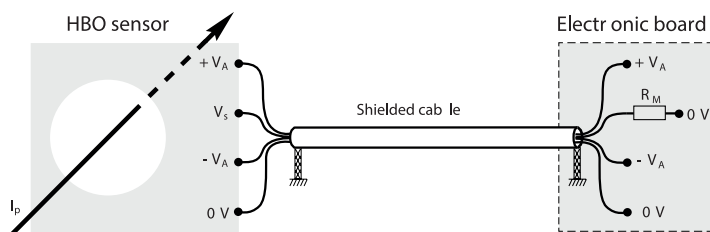

4 - Processing of the sensor's output signal

Standard codes of practice advise that, before the signal is processed, a low-pass filter adapted to the bandwidth of the sensor is used.

Moreover, in the case of digital processing of the signal, it is also recommended that the sampling frequency is adapted to the bandwidth of both the signal to be measured and the sensor.

In the event of sensor failure, the processing of the output signal should take into account this deterioration in performance (e.g. absence of signal or saturated signal) and rapidly and safely shut the system down.

Electronic voltage sensors

Instructions for mounting and wiring VS sensors

Introduction

These instructions are a non-exhaustive synthesis of the main recommendations for mounting VS voltage sensors. Each application configuration is different, do not hesitate to contact us for advice adapted to your particular case.

Please note that incorrect or non-judicious use of sensors may lead to deterioration in the performance or operation of the sensor.

Please refer to the mounting instructions ref. **1SBC147000M1702** (VS050 to VS1500) and ref. **1SBC146012M1701** (VS2000 to VS4200) for further information.

1 - Wiring diagram

— Direction of the current: A positive primary differential voltage ($U_p = U_{HT+} - U_{HT-} > 0$) results in a positive secondary output current I_s from terminal M.

— Supply voltage: bipolar voltage $-V_A \dots 0V \dots +V_A$

VS sensors can also operate with a unipolar supply voltage ($-V_A \dots 0V$ ou $0V \dots +V_A$) under certain conditions.

Please contact your distributor for further details for this application.

1.1 - VS voltage sensors with screen

The best EMC performance is obtained by connecting the screen terminal "E" to earth by a copper braid strap as short as possible.

If the electromagnetic interference is weak the screen terminal "E" can be connected to the sensor negative secondary terminal (marked "-").

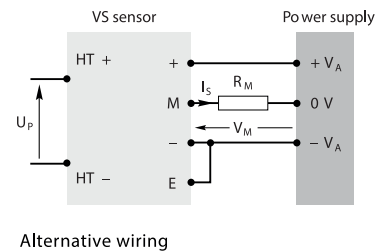
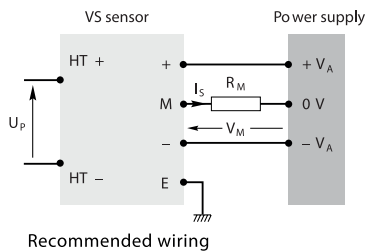

1.2 - VS voltage sensors without screen

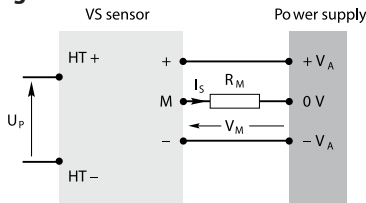

2 - Mechanical mounting

All mounting positions are possible: horizontal, vertical, upside down, on edge.

Minimum distance between 2 sensors: 1 cm.

Recommended fixing: 2 M6 screws with flat washers.

Electronic voltage sensors

Instructions for mounting and wiring VS sensors

4

3 - Precautions to be taken into account, relative to the electromagnetic environment

- Best performance is obtained in an environment with low electromagnetic interference.
- Electromagnetic interference is generated by the switching of strong currents (e.g.: switch relay), high voltage switchgear (e.g.: semi-conductor choppers), high intensity radio environment (e.g.: radio communication equipment).
- With the aim of minimising the effects of strong electromagnetic interference, please refer to standard rules (current working practice) and especially the following:
 - It is recommended that the sensor be fixed by its enclosure to a conducting plate that is connected to a stable potential (e.g.: earth ground plate).
 - It is recommended that the secondary be connected with a shielded cable (with the shielding connected to both cable ends and with a minimum length of wire as possible extending beyond the shielding).

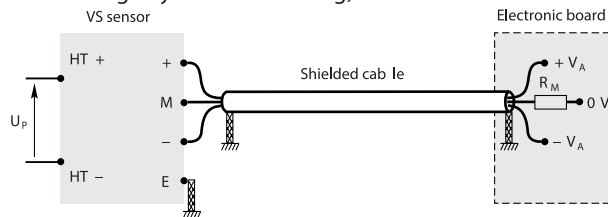

- It is recommended that the screen terminal "E" be connected to earth with a copper braid strap as short as possible (length not to exceed five times its width).
- It is recommended that the primary and secondary cables are separated.
- It is recommended that the two primary cables are fixed together (e.g. with cable clamps).
- It is strongly recommended that the primary and secondary cables connected to the sensors, are fixed to the earth ground plates or metal frame in order to minimise the interference induced in these cables.

4 - Processing of the sensor's output signal

Standard codes of practice advise that, before the signal is processed, a low-pass filter adapted to the bandwidth of the sensor is used. Moreover, in the case of digital processing of the signal, it is also recommended that the sampling frequency is adapted to the bandwidth of both the signal to be measured and the sensor. In the event of sensor failure, the processing of the output signal should take into account deterioration in performance (e.g. absence of signal or saturated signal) and rapidly and safely shut the system down.

Warning: The VS voltage sensor incorporates a switched mode power supply with a chopping frequency set at around 50 kHz.

5 - Dedicated technical documentation to VS technology

Because of the need on more precise technical information on VS sensors, following documentation is available: 1SBD370318R1001 VS tests in the field. This document approaches the different possibilities to investigate, from basic to complex tests, the good operation of a VS sensor. The EMC subject is also presented.

Electronic voltage sensors

Instructions for mounting and wiring VD detectors

Introduction

These instructions are a non-exhaustive synthesis of the main recommendations for mounting VD voltage detectors. Each application configuration is different, please do not hesitate to contact us for advice adapted to your particular case. Please note that incorrect or non-judicious use of the sensor may lead to deterioration in the performance or operation of the sensor.

1 - Wiring diagram

The VD voltage detector is a very reliable product, consequently the wiring is an important point to take into account. The following points must be respected:

- The VD voltage detector connections wires must be dedicated to High Voltage only,
- The 4 screws used must respect the following specification:
 - M5x7 insert for connections : screw M5 with flat washer. Tightening torque: 2 Nm.

It is also recommended that the LED (Light Emitting Diode) lenses are only removed during maintenance operations by qualified personnel.

1.1 - Redundancy function

In order to ensure that the detector works correctly and permanently, it includes two times the same function as explained opposite.

In order to operate accordingly, the VD detector must be connected using the 4 primary terminals:

- The first LED operates when the terminals HT1+ and HT1- are connected,
- The second LED operates when the terminals HT2+ and HT2- are connected.

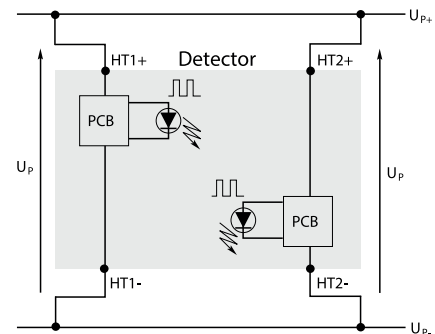

1.2 - High voltage connection

Before connecting the high voltage cable to the VD voltage detector, the operator must make sure that the identification of the terminals is clearly marked without the possibility of confusion.

The correct identification of the High Voltage terminals is shown opposite: The detector operates correctly when the polarity of the terminals is respected as follows:

- The positive High Voltage is connected to HT1+ and HT2+ with 2 different cables coming from the 2 different connection points,
- The negative High Voltage is connected to HT1- and HT2- with 2 different cables coming from the 2 different connection points.



2 - Mechanical mounting

2.1 - Fixing by the enclosure

From the security point of view, it is very important that the VD voltage detector is fixed in the best possible mechanical conditions:

- The detector may be mounted in all positions (horizontal, vertical, upside down, on edge) but the two M6 screws must be checked that they are correctly tightened on the detector with a system to prevent nuts becoming loose
- The use of flat washers under the nuts is generally recommended
- The surface where the detector is mounted, is sufficiently flat
- The location where the detector is mounted is not subject to high vibration levels
- The maintenance personnel have easy and quick access to the device
- The 2 LEDs are easily visible to the appropriate persons

2.2 Environment around the LEDs

The recommended visual inspection distance for checking the LEDs should not exceed 2 metres between the operators eyes and the LED. The ambient light should not exceed 1000 lux. This distance may be increased if the voltage detector is placed in a location where the daylight has a small influence on the visual indication of the LED.

For normal and regular checking of the LEDs, the operators eyes should be within an angle of $\pm 15^\circ$ from the LEDs axis. For further information, please do not hesitate to contact your distributor or refer to the mounting Instructions.

Electronic voltage sensors

Instructions for mounting and wiring VD detectors

3 - 1st switching on of the detector

After applying high voltage to the primary terminals of the VD voltage detector, pay attention to the following points:

- do not touch the HT terminals (high voltage) of the VD voltage detector
- do not try to remove the lenses of the LEDs

4

Checking correct functioning

The VD voltage detector LEDs should flash about every 0.5 seconds as soon as the dangerous voltage U_{ON} is passed. The LEDs should remain extinguished below U_{OFF} (see the detailed characteristics of the VD1500 voltage detector). In the event that LEDs do not work when high voltage is applied:

- electrically isolate the system
- make sure that no residual voltage is present in the VD voltage detector (voltmeter or other means)
- check that the VD voltage detector wiring is correct (this may explain why the LEDs do not work)

If no faults are found in the installation, carry out a complete replacement of the voltage detector.

Please contact your distributor for further information on this subject or refer to the document *Voltage Detector usage - Preventive and Curative Maintenance*.

Calculation guide

Closed loop Hall effect current sensors ES, CS, MP and EL sensors



ES300C

1 - Reminder of the key elements (closed loop Hall effect)

Formulas

$$N_P \times I_P = N_S \times I_S$$

$$V_A = e + V_S + V_M$$

$$V_S = R_S \times I_S$$

$$V_M = R_M \times I_S$$

Abbreviations

- N_P : turn number of the primary winding
- I_P : primary current
- I_{PN} : nominal primary current
- N_S : turn number of the secondary winding
- I_S : output secondary current
- V_A : supply voltage
- e : voltage drop across output transistors (and in the protection diodes, if relevant)
- V_S : voltage drop across secondary winding
- V_M : measuring voltage
- R_S : resistance of the secondary winding
- R_M : measuring resistance

Values of "e" with a bipolar sensor supply

Sensor	ES100	ES300...ES2000	CS300...CS1000	CS2000	MP or EL
Voltage "e"	2.5 V	1 V	2.5 V	1.5 V	3 V

Reminder of the sensor electrical connection

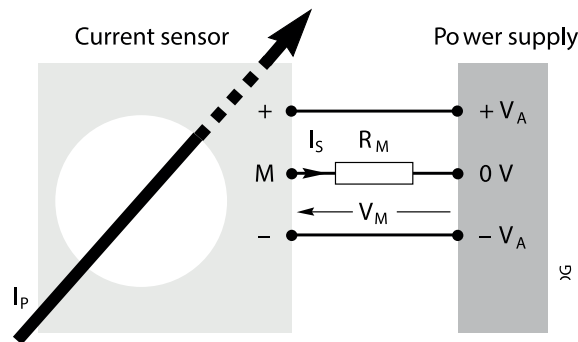

2 - Measurement circuit calculation (secondary part of the sensor)

Example with ES300C sensor

- $N_P/N_S = 1/2000$
- $I_{PN} = 300 \text{ A}$
- $R_S = 33 \text{ } \Omega$ (at +70 °C)
- $I_S = 0.15 \text{ A}$ (at I_{PN})
- $e = 1 \text{ V}$

2.1 - What load resistance (R_M) is required to obtain an 8 V measuring signal ($V_M = 8 \text{ V}$) when the IP current = 520 A peak?

$$I_S = (N_P / N_S) \times I_P = (1 / 2000) \times 520 = 0.26 \text{ A peak}$$

$$R_M = V_M / I_S = 8 / 0.26 = 30.77 \text{ } \Omega$$

We must check that the sensor can measure these 520 A peak, i.e.:

$$V_A \geq e + V_S + V_M$$

If $V_A = \pm 15 \text{ V}$ ($\pm 5\%$), then we must check that

$$15 \times 0.95 \geq 1 + (33 \times 0.26) + 8 \text{ which is false since } 14.25 \text{ V} < 17.58 \text{ V}$$

Therefore a supply greater than or equal to 17.58 V must be selected. Select a $\pm 24 \text{ V}$ ($\pm 5\%$) supply.

We verify that $24 \times 0.95 \geq 17.58 \text{ V}$.

Conclusion

An ES300C sensor can measure a peak of 520 A in the following conditions:

$$V_A = \pm 24 \text{ V} (\pm 5\%)$$

$$R_M = 30.77 \text{ } \Omega$$

to obtain an 8 V signal at a peak of 520 A

Calculation guide

Closed loop Hall effect current sensors

ES, CS, MP and EL sensors

4



ES300C

2.2 - What are the consequences, if the required signal is only 5 V?

$$R_M = V_M / I_S = 5 / 0.26 = 19.23 \Omega$$

We must check that the sensor can measure these 520 A peak.

$$V_A \geq e + V_S + V_M$$

If $V_A = \pm 15 \text{ V}$ ($\pm 5\%$), then we must check that

$$15 \times 0.95 > 1 + (33 \times 0.26) + 5 \text{ which is false since } 14.25 \text{ V} < 14.58 \text{ V}$$

Therefore a supply greater than or equal to 14.58 V must be selected. Select a $\pm 24 \text{ V}$ ($\pm 5\%$) supply or a $\pm 15 \text{ V}$ supply with a tighter tolerance, for example $\pm 15 \text{ V}$ ($\pm 2\%$).

(since $15 \text{ V} \times 0.98 \geq 14.58 \text{ V}$)

Conclusion

An ES300C sensor can measure a peak of 520 A in the following conditions:

$$V_A = \pm 15 \text{ V} (\pm 2\%)$$

$$R_M = 19.23 \Omega$$

to obtain a 5 V signal at a peak of 520 A.

In general, the larger the measuring signal required, the larger the load resistance and the higher the sensor supply voltage should be. The thermal aspect of the sensor should be considered.

2.3 - What is the maximum current measurable by an ES300C in specific conditions?

For example, the conditions are:

$$V_A = \pm 15 \text{ V} (\pm 5\%)$$

$$R_M = 15 \Omega$$

From the base formulas, we obtain the following formula:

$$I_{S\text{MAX}} = (V_{A\text{MIN}} - e) / (R_S + R_M) = [(15 \times 0.95) - 1] / (33 + 15) = 0.276 \text{ A peak}$$

Now calculate the equivalent primary current:

$$I_P = (N_S / N_P) \times I_S = (2000 / 1) \times 0.276 = 552 \text{ A peak}$$

Conclusion

An ES300C sensor can measure a peak of 552 A in the following conditions:

$$V_A = \pm 15 \text{ V} (\pm 5\%)$$

$$R_M = 15 \Omega$$

Note: the 552 A peak current must not be a continuous current. For specific requirements, contact your distributor.

2.4 - What influence does the ambient temperature have on the sensor's performance?

Taking the conditions from point 2.3 (preceding example). The calculations were made using a maximum default operating temperature of $+70 \text{ }^\circ\text{C}$. If this maximum temperature is $+50 \text{ }^\circ\text{C}$, then the measuring range can be increased as follows:

$$R_S = 33 \Omega \text{ at } +70 \text{ }^\circ\text{C} \quad \text{At } +50 \text{ }^\circ\text{C}, R_S = 30.5 \Omega \quad \text{then,}$$

$$I_{S\text{MAX}} = (V_{A\text{MIN}} - e) / (R_S + R_M) = [(15 \times 0.95) - 1] / (30.5 + 15) = 0.291 \text{ A peak}$$

Now calculate the equivalent primary current:

$$I_P = (N_S / N_P) \times I_S = (2000 / 1) \times 0.291 = 582 \text{ A peak}$$

Conclusion

An ES300C sensor can measure a peak of 582 A in the following conditions:

$$V_A = \pm 15 \text{ V} (\pm 5\%)$$

$$R_M = 15 \Omega$$

Max. operating temperature = $+50 \text{ }^\circ\text{C}$

Note: the 582 A peak current must not be a continuous current. For specific requirements, contact your distributor.

In general, the lower the ambient temperature, the more important the sensor measurable current. The thermal aspect of the sensor should be considered.

Calculation guide

Closed loop Hall effect current sensors ES, CS, MP and EL sensors



ES300C

2.5 - What influence does the turn ratio have on the sensor's performance?

Taking the conditions of point 2.3 again. The calculations were based on a turn ratio of 1/2000. If this ratio is 1/1500 (non standard ratio for a 300 A sensor), then the elements are determined as follows:

$$I_S = (N_P / N_S) \times I_P = (1 / 1500) \times 552 = 0.368 \text{ peak} \quad (I_P = 522 \text{ A from 2.3 above})$$

Now calculate the voltage obtained at the terminals of the measuring resistance:

☒ for a turn ratio of 1/2000:

$$V_M = R_M \times I_S = 15 \times 0.276 = 4.14 \text{ V}$$

☒ for a turn ratio of 1/1500:

$$V_M = R_M \times I_S = 15 \times 0.368 = 5.52 \text{ V}$$

Conclusion

An ES300C sensor can measure a peak of 552 A in the following conditions

$$V_A = \pm 15 \text{ V } (\pm 5\%)$$

$$R_M = 15 \text{ } \Omega$$

$$V_M = 4.14 \text{ V with a turn ratio of 1/2000}$$

$$V_M = 5.52 \text{ V with a turn ratio of 1/1500}$$

In general, the lower the turn ratio, the more important the output current and the higher the measuring voltage. The thermal aspect of the sensor should be considered.

2.6 - What influence does the supply voltage have on the sensor's performance?

Taking the conditions in point 2.3 again. The calculations were based on a supply voltage of $\pm 15 \text{ V } (\pm 5\%)$.

Reworking the calculations with a supply of $\pm 24 \text{ V } (\pm 5\%)$.

From the base formulas, we obtain the following formula:

$$I_{S_{MAX}} = (V_{AMIN} - e) / (R_S + R_M) = [(24 \times 0.95) - 1] / (33 + 15) = 0.454 \text{ A peak}$$

Now calculate the equivalent primary current:

$$I_P = (N_S / N_P) \times I_S = (2000 / 1) \times 0.454 = 908 \text{ A peak}$$

Conclusion

An ES300C sensor can measure a peak of 908 A in the following conditions:

$$V_A = \pm 24 \text{ V } (\pm 5\%)$$

$$R_M = 15 \text{ } \Omega$$

Note: the 908 A peak current must not be a continuous current.

In general, the higher the supply voltage, the more important the measuring current and the higher the measuring voltage. The thermal aspect of the sensor should be considered.

NB: for calculations with unipolar supply (e.g. 0...+24 V), contact your distributor.

Calculation guide

Electronic technology current sensors NCS sensors

4



NCS125-10

1 - Reminder of the key elements

Formulas

$$V_{M1} = R_{M1} \times I_{S1}$$

$$V_{M2} = R_{M2} \times I_{S2}$$

$$\text{with } 0 \Omega < R_{M1} \text{ or } R_{M2} < 350 \Omega$$

Abbreviations

I_P	: primary current
I_{PN}	: nominal primary current
$I_{P_{MAX}}$: maximum primary current
I_{S1}	: secondary current at I_{PN}
I_{S2}	: secondary current at $I_{P_{MAX}}$
V_{S1}	: secondary voltage at I_{PN}
V_{S2}	: secondary voltage at $I_{P_{MAX}}$
V_A	: supply voltage
V_M	: measuring voltage
R_M	: measuring resistance
$R_{M_{MIN}}$: minimum measuring resistance
$R_{M_{MAX}}$: maximal measuring resistance

Reminder of the sensor electrical connection

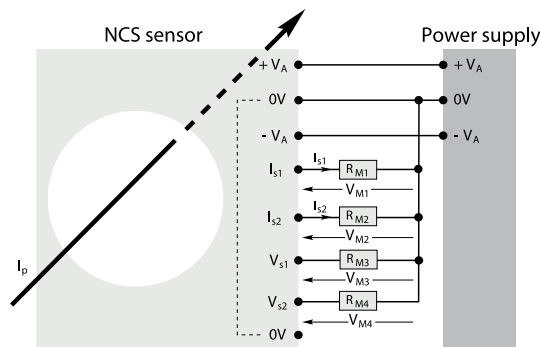

2 - Measurement circuit calculation (current output)

Example with NCS125-4 sensor

I_{PN}	= 4 000 A	$I_{S1} @ I_{PN}$	= ±20 mA
$I_{P_{MAX}}$	= 20 000 A	$I_{S2} @ I_{P_{MAX}}$	= ±20 mA
R_M	= 0 - 350 Ω (I_{S1} & I_{S2})	$V_{S1} @ I_{PN}$	= ±10 V
R_M	≥ 10 k Ω (V_{S2} & V_{S2})	$V_{S2} @ I_{P_{MAX}}$	= ±10 V
V_A	= ±15 V ... ±24 V		

The design of the sensor requires that 2 operating points are respected on the outputs I_{S1} and I_{S2} :

- A maximum measuring voltage of 7 V DC ($V_{M_{MAX}} \leq R_{M_{MAX}} \times I_{S_{MAX}}$)
- A maximum output current of ±20 mA DC.

The supply voltage does not have any influence on the output signals.

2.1 - What load resistance (R_M) is required to obtain a 5 V measuring ($V_M = 5$ V) when the current $I_P = 6000$ A peak?

The measured current is greater than I_{PN} (4000 A for a NCS125-4), I_{S2} is therefore used as the measuring signal.

Firstly the output current on I_{S2} must be calculated when $I_{PN} = 6000$ A DC

$$I_{S2} = I_{PN} / I_{P_{MAX}} \times I_{S_{MAX}} = 6000 / 20000 \times 20 = 6 \text{ mA (correct because } I_{S2_{MAX}} = \pm 20 \text{ mA DC)}$$

Now determine the value of the resistance R_M

$$R_M = V_M / I_{S2} = 5 / 0.006 = 833.33 \Omega$$

Conclusion

The NCS125-4 sensor can measure 6000 A peak on the signal output I_{S2} with a resistance of 416.67 Ω (greater than 350 Ω) because the output current is smaller than $I_{S_{MAX}}$ i.e. 20 mA DC

The product of $R_M \times I_{S_{MAX}}$ must always be smaller than or equal to maximum output of 7 V DC

3 - Measurement circuit calculation (voltage output)

No special calculation needs to be made. This NCS sensor range supplies a voltage directly proportional to the primary current I_P between -10 V and +10 V. A load resistance of a value greater than or equal to 10 k Ω adapts the impedance of the measured output (V_{S1} or V_{S2}) to the acquisition system.

Calculation guide

Electronic technology voltage sensors VS sensors

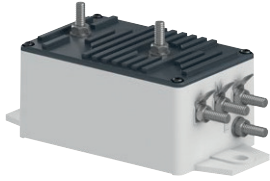

VS1000B

1 - Reminder of the key elements

Formulas

$$V_M = R_M \times I_S \text{ and } \frac{U_{PN}}{I_{SN}} = \frac{U_P}{I_S}$$

VS50 ... VS1500:

$$\begin{aligned} \boxtimes R_M &= [(0.8 \times V_{AMIN}) / I_S] - 55 \\ \boxtimes U_{HT+} + U_{HT-} &\leq 4.2 \text{ kV peak and} \\ |U_{HT+} - U_{HT-}| &\leq U_{P_{MAX}} \end{aligned}$$

VS2000 ... VS4200 :

$$\begin{aligned} \boxtimes R_M &= [(0.8 \times V_{AMIN}) / I_S] - 60 \\ \boxtimes U_{HT+} + U_{HT-} &\leq 10 \text{ kV peak and} \\ |U_{HT+} - U_{HT-}| &\leq U_{P_{MAX}} \end{aligned}$$

Abbreviations

U_P	: primary voltage
U_{PN}	: nominal primary voltage
I_S	: secondary current
I_{SN}	: nominal secondary current
V_A	: supply voltage
V_{AMIN}	: V_A less lowest supply tolerance
V_M	: measuring voltage
R_M	: measuring resistance

Reminder of the sensor electrical connection

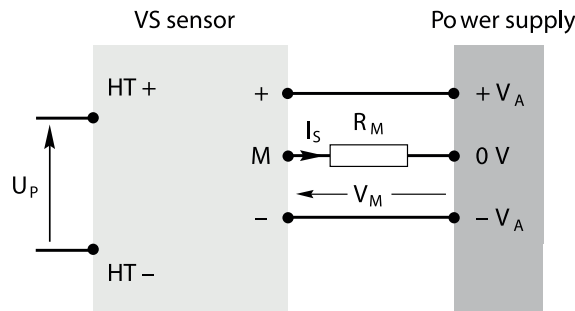

2 - Measurement circuit calculation (secondary part of the sensor)

Example with VS1000B sensor

$$\begin{aligned} U_{PN} &= 1000 \text{ V} \\ I_{SN} &= 50 \text{ mA} \\ V_A &= \pm 24 \text{ V } (\pm 5\%) \\ U_{P_{MAX}} &= 1500 \text{ V} \end{aligned}$$

2.1 - What load resistance (R_M) is required to obtain a 10 V measuring signal ($V_M = 10 \text{ V}$) when the voltage $U_{P_{MAX}} = 1500 \text{ V}$ peak?

$$\begin{aligned} I_S &= I_{SN} \times U_{P_{MAX}} / U_{PN} = 0.050 \times 1500 / 1000 \quad \text{i.e. } I_S = 75 \text{ mA} \\ R_M &= V_M / I_S = 10 / 0.075 \quad \text{i.e. } R_M = 133.33 \text{ } \Omega \end{aligned}$$

We must check that the sensor can measure this 1500 V with a $\pm 24 \text{ V } (\pm 5\%)$ supply

$$V_{AMIN} = 24 \times 0.95 = 22.8 \text{ V}$$

$$R_M = [(0.8 \times V_{AMIN}) / I_S] - 55 = [(0.8 \times 22.8) / 0.075] - 55 \quad \text{i.e. } R_M = 188.2 \text{ } \Omega$$

We therefore verify that the sensor can measure this 1500 V voltage since the measuring resistance with a $\pm 24 \text{ V } (\pm 5\%)$ supply is 188.2 Ω for 133.33 Ω required.

Conclusion

A VS1000B sensor can measure a peak of 1500 V in the following conditions:

$$V_A = \pm 24 \text{ V } (\pm 5\%)$$

$$R_M = 133.33 \text{ } \Omega$$

to obtain a 10 V signal at 1500 V peak.

Calculation guide

Electronic technology voltage sensors VS sensors

4

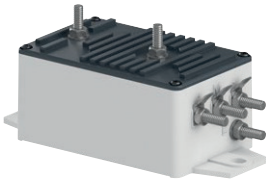

VS1000B

2.2 - What are the consequences, if the required signal is only 5 V ($V_M = 5$ V)?

In the same way as for closed loop Hall effect current sensors, if the required measuring voltage is reduced, carefully check that the ± 15 V ($\pm 5\%$) supply used in this example is sufficient to obtain a 5 V signal with the conditions used in the preceding point.

$$R_M = V_M / I_S = 5 / 0.075 \quad \text{i.e. } R_M = 66.67 \, \Omega$$

$$R_M = [(0.8 \times V_{AMIN}) / I_S] - 55 = [(0.8 \times 14.25) / 0.075] - 55 \quad \text{i.e. } R_M = 97 \, \Omega$$

We therefore verify that the sensor measures this 1500 V voltage since the measuring resistance with a ± 15 V ($\pm 5\%$) supply is $97 \, \Omega$ for $66.67 \, \Omega$ required.

2.3 - What is the maximum measurable voltage by a VS1000B in specific conditions?

An electronic voltage sensor is also sensitive to the thermal aspect.

In general, a VS voltage sensor can withstand up to 150% of the nominal primary voltage, but only under certain conditions.

In all these cases, we recommend that you contact your distributor in order to obtain detailed information on this subject.

2.4 - What influence does the ambient temperature have on the sensor's performance?

The electronic voltage sensor design means that the maximum operating temperature influences the sensor's performance, notably the measurement accuracy. However there is no correlation between a reduction in the ambient temperature and an increase in the voltage to be measured.

2.5 - What influence does the supply voltage have on the sensor performance?

In general, the higher the supply voltage, the higher the measuring voltage. The thermal aspect of the sensor should be considered.

NB: for calculations with unipolar supply (e.g. $0 \dots +24$ V), contact your distributor.

2.6 - What influence does the temperature have on the sensor's life time?

From a general point of view, with whatever product, the more the temperature, the less the life time. With the VS sensors, the temperature also reduces the life time above $40 \, ^\circ\text{C}$. The factor of reduction is however very much depending on the way the VS sensors are used in the application. Please contact your local supplier for further information.

3 - Sensor primary circuit calculation

Maximum common mode voltage

Can the VS1000B sensor ($U_{PMAX} = 1500$ V peak) be used to measure a differential voltage

$U_P = U_{HT+} - U_{HT-}$ with $U_{HT+} = 3500$ V DC and $U_{HT-} = 2600$ V DC ?

$$3.1 - |U_{HT+} - U_{HT-}| = |3500 - 2600| = 900 \text{ V DC} \leq 1500 \text{ V peak} :$$

First condition $|U_{HT+} - U_{HT-}| \leq U_{PMAX}$ is therefore fulfilled.

$$3.2 - U_{HT+} + U_{HT-} = 3500 + 2600 = 6100 \text{ V DC} > 4.2 \text{ kV peak} :$$

Second condition $U_{HT+} + U_{HT-} \leq 4.2$ kV peak is not therefore fulfilled.

Conclusion

The VS1000B sensor cannot therefore be used to measure this 900 V DC primary differential voltage (even though this differential voltage is lower than the nominal primary voltage of the VS1000B sensor).

For this application the VS2000B sensor can be used since:

$$U_{HT+} + U_{HT-} = 6100 \text{ V DC} \leq 10 \text{ kV peak}$$

The condition $U_{HT+} + U_{HT-} \leq 10$ kV peak is therefore fulfilled with the VS2000B.

Questionnaire

Current and voltage sensor selection guide

General

The following questionnaires are used to select sensors according to the client's requirements.

The characteristics shown in the catalogue are given with respect to a defined environment (worst case conditions).

The technical requirements will not always reach these extreme limits, and it is possible, following confirmation by us, to propose higher maximum electrical or thermal values to those published, thanks to a knowledge and detailed analysis of the sensor operating environment.

A technical relationship between the client and PETERCEM will allow the proposal of the best selection of sensors, equally from the viewpoint of performance and economy.

Two principal areas are considered in the selection of a sensor:

- the electrical aspect
- the thermal aspect

The sensor performance is based on a combination of electrical and thermal conditions; any values other than those indicated in this catalogue cannot be guaranteed unless validated by us. The information below is only valid for sensors using closed loop Hall effect technology.

Contact your local supplier for other technologies.

Profile mission

Due to the design of converters with integrate more power with less volume, sensors are very constraint; leading to reduce their life time. As a matter of fact, even though the application main conditions are well within the sensors characteristics, these conditions have an impact on the sensor life time.

The main general characteristics that involves the sensors life time are the following:

- the ambient temperature above 40 °C. It is usually said that every additional 10 °C, the life time is reduced by a factor of 2. Of course, this value is a theoretical value and has to be defined in line with the concerned project.
- the ambient temperature variations also impact the sensor life time. Even small variations (like 10 °C) can change the life time of the sensor especially on the electronic part.
- the way the sensors are used also impact its duration (numbers of ON/OFF per day, average current or voltage value, power supply value, load resistor value, vibrations levels...)

The above general impacting conditions are well defined in standards like IEC 62380, UTE C 80-810 and must be consider during any new converter design.

PETERCEM can provide theoretical reliability calculation based on specific profile mission of your projects.

Electrical characteristics

The electrical characteristics values mentioned in this catalogue are given for a particular sensor operating point. These values may vary, according to the specific technical requirement, in the following way:

- The primary thermal current (voltage) (IPN or UPN) may be increased if:
 - the maximum operating temperature is lower than the value shown in the technical data sheet
 - the sensor supply voltage (VA) is reduced
 - the load resistance value (RM) is increased
- The maximum current (voltage) measurable by the sensor may be increased if:
 - the maximum operating temperature is lower than the value shown in the technical data sheet
 - the sensor supply voltage (VA) is increased
 - the secondary winding resistance value (RS) is reduced (e.g. by using a lower transformation ratio)
 - the load resistance value (RM) is reduced

Thermal characteristics

The operating temperature values mentioned in this catalogue are given for a particular sensor operating point. These values may vary, according to the specific technical requirement, in the following way:

- The maximum operating temperature may be increased if:
 - the primary thermal current (voltage) (IPN or UPN) is reduced
 - the sensor supply voltage (VA) is reduced
 - the load resistance value (RM) is increased

PS: The minimum operating temperature cannot be lower than that shown in the technical data sheet as this is fixed by the lower temperature limit of the components used in the sensor.

Questionnaire

Industry current sensor selection

5

Company: Name:

Address:

Tel: Fax: Email:

Application

- 1. Application :
 - Variable speed drive
 - UPS
 - Wind generator
 - Active harmonic filter
 - Welding machines
 - Solar
 - Other (description)
- 2. Quantity per year:

Mechanical characteristics

- 1. Sensor fixing:
 - By soldering to the PCB
 - By the enclosure
 - By the primary conductor
- 2. Primary conductor:
 - Cable diameter (mm)
 - Cable connection size (mm)
 - Bar size (mm)
- 3. Secondary connection:
 - By connector
 - By cable without connector
 - Other

Sensor environmental conditions

- 1. Minimum operating temperature (°C)
- 2. Maximum operating temperature (°C)
- 3. Presence of strong electromagnetic fields
- 4. Max. continuous primary conductor voltage (V)
- 5. Main reference standards

Other requirements (description)

.....
.....
.....
.....

Electrical characteristics

- 1. Nominal current (I_{PN}) (A r.m.s.)
- 2. Current type (if possible, show current profile on graph):
 - Direct
 - Alternating
- 3. Bandwidth to be measured (Hz)
- 4. Current measuring range:
 - Minimum current (A)
 - Maximum current (A)
 - Duration (of max. current) (sec)
 - Repetition (of max. current)
 - Measuring voltage (on R_M) at max current (V)
- 5. Overload current (not measurable):
 - Not measurable overload current (A)
 - Duration (sec)
 - Repetition.....
- 6. Sensor supply voltage:
 - Bipolar supply voltage ($\pm V$)
 - Unipolar supply voltage (0 +V or 0 -V)
- 7. Output current
 - Secondary current at nominal current I_{PN} (mA)
- 8. Current output (NCS range only)
 - Secondary current at maximum current $I_{P_{MAX}}$ (mA)
- 9. Voltage output
 - Secondary voltage at nominal current I_{PN} (V)
- 10. Voltage output (NCS range only)
 - Secondary voltage at maximum current $I_{P_{MAX}}$ (V)

This document is used for selecting sensors according to the application and the clients requirements.

Questionnaire

Railway current sensor selection

Company: Name:

Address:

Tel: Fax: Email:

Application

- 1. Project name
- 2. Application:
 - Rolling stock:
 - Power converter
 - Auxiliary converter
 - Other
 - Short or long distance train:
 - Power converter
 - Auxiliary converter
 - Metro or tramway:
 - Power converter
 - Auxiliary converter
- Fixed installation (e.g. substtion)
- 3. Quantity per year:
- 4. Total quantity for the projet

Mechanical characteristics

- 1. Sensor fixing:
 - By the enclosure
 - By the primary conductor
- 2. Primary conductor:
 - Cable diameter (mm)
 - Bar size (mm)
- 3. Secondary connection:
 - Screw or Faston
 - By connector
 - By shielded cable
 - Other

Electrical characteristics

- 1. Nominal current (I_{PN}) (A r.m.s.)
- 2. Current type (if possible, show current profile on graph):
 - Direct
 - Alternating
- 3. Bandwidth to be measured..... (Hz)
- 4. Current measuring range:
 - Minimum current(A)
 - Maximum current(A)
 - Duration (of max. current) (sec)
 - Repetition (of max. current)
 - Measuring voltage (on RM) at max current (V)
- 5. Overload current (not measurable):
 - Not measurable overload current(A)
 - Duration (sec)
 - Repetition
- 6. Sensor supply voltage:
 - Bipolar supply voltage(±V)
 - Unipolar supply voltage (0 +V or 0 -V)
- 7. Output current
 - Secondary current at nominal current I_{PN} (mA)
- 8. Current output (NCS125 & NCS165 only for fixed installations)
 - Secondary current at maximum current $I_{P_{MAX}}$ (mA)
- 9. Voltage output (NCS125 & NCS165 only for fixed installations)
 - Secondary voltage at nominal current I_{PN} (V)
- 10. Voltage output (NCS125 & NCS165 only for fixed installations)
 - Secondary voltage at maximum current $I_{P_{MAX}}$ (V)

Sensor environmental conditions

- 1. Minimum operating temperature (°C)
- 2. Maximum operating temperature (°C)
- 3. Average nominal operating temperature (°C)
- 4. Maximum continuous primary conductor voltage (V)
- 5. Main reference standards

Other requirements (description)

.....
.....
.....
.....

This document is used for selecting sensors according to the application and the clients requirements.

Questionnaire

Railway voltage sensor selection

5

Company: Name:

Address:

Tel: Fax: Email:

Application

- 1. Project name
- 2. Application:
 - Short or long distance train:
 - Power converter
 - Auxiliary converter
 - Metro or tramway:
 - Power converter
 - Auxiliary converter
 - Fixed installation (e.g. substation)
- 3. Quantity per year:
- 4. Total quantity for the project

Mechanical characteristics

- 1. Primary connection:
 - By screw
 - Other
- 2. Secondary connection:
 - Screw or Faston
 - By connector
 - Other

Sensor environmental conditions

- 1. Minimum operating temperature(°C)
- 2. Maximum operating temperature(°C)
- 3. Average nominal operating temperature(°C)
- 4. Main reference standards

Electrical characteristics

- 1. Nominal voltage (U_{PN}) (V r.m.s.)
- 2. Voltage type (if possible, show voltage profile on graph):
 - Direct
 - Alternating
- 3. Bandwidth to be measured(Hz)
- 4. Voltage measuring range:
 - Minimum voltage(V)
 - Maximum voltage(V)
 - Duration (at max. voltage)(sec)
 - Repetition (at max. voltage)
 - Measuring voltage (on R_M) at max voltage(V)
- 5. Overload voltage (not measurable):
 - Not measurable overload voltage(V)
 - Duration(sec)
 - Repetition.....
 - Category (from OV1 to OV3).....
- 6. Sensor supply voltage:
 - Bipolar supply voltage ($\pm V$)
 - Unipolar supply voltage (0 +V or 0 -V)
- 7. Output current
 - Secondary current at nominal voltage U_{PN} (mA)

Other requirements (description)

.....
.....
.....
.....

This document is used for selecting sensors according to the application and the clients requirements.

Questionnaire

Voltage detector selection

Company: Name:

Address:

Tel: Fax: Email:

Application

- 1. Project name
- 2. Application:
 - Short or long distance train:
 - Power converter
 - Auxiliary converter
 - Metro or tramway:
 - Power converter
 - Auxiliary converter
 - Fixed equipment (e.g. substation)
- 3. Quantity per year:
- 4. Total quantity for the project.....

Sensor environmental conditions

- 1. Minimum operating temperature (°C)
- 2. Maximum operating temperature (°C)
- 3. Average nominal operating temperature (°C)
- 4. Pollution degree.....
- 5. Over voltage category (from OV1 to OV3).....
- 6. Maximum ambient light level (lux)
- 7. Main reference standards

Electrical characteristics

- 1. Nominal voltage (U_{PN}) (V DC)
- 2. Maximum voltage long duration: 5 min (U_{MAX2}) (V DC)
- 3. Maximum voltage overload: 20 ms (U_{MAX3}) (V DC)
- 4. Minimum voltage to be detected (V)

Other requirements (description)

.....
.....
.....
.....

This document is used for selecting sensors according to the application and the clients requirements.

Index

Order code and type classification

Order code	Type	Pag e	Order code	Type	Pag e	Type	Order code	Pag e	Type	Order code	Pag e
1SBT130100R0001	EL100P2	16	1SBT171000R9941	CS1000-9941	56	Bar kit CST0	1SBT170000R2003	57	MP25P1	1SBT312500R0001	16
1SBT130100R0002	EL100P2BB	16	1SBT171000R9942	CS1000-9942	56	Bar kit CST1 special	1SBT170000R2010	57	NCS125-10	1SBT200210R0001	26
1SBT132500R0001	EL25P1	16	1SBT171000R9943	CS1000-9943	56	Bar kit CST1-10	1SBT170000R2005	57	NCS125-10AF	1SBT200210R0002	26
1SBT132500R0002	EL25P1BB	16	1SBT172000R0003	CS2000BR	56	Bar kit CST1-6	1SBT170000R2004	57	NCS125-10VF	1SBT200210R0102	26
1SBT135100R0001	EL50P1	16	1SBT172000R0004	CS2000BRV	56	Bar kit CST2	1SBT170000R2008	57	NCS125-4	1SBT200204R0001	26
1SBT135100R0002	EL55P2	16	1SBT172000R9944	CS2000-9944	56	Bar kit CST2 special	1SBT170000R2012	57	NCS125-4AF	1SBT200204R0002	26
1SBT135100R0003	EL50P1BB	16	1SBT172000R9945	CS2000-9945	56	CS1000-9940	1SBT171000R9940	56	NCS125-4VF	1SBT200204R0102	26
1SBT135100R0004	EL55P2BB	16	1SBT200204R0001	NCS125-4	26	CS1000-9941	1SBT171000R9941	56	NCS125-6	1SBT200206R0001	26
1SBT150100R0001	ES100C	17	1SBT200204R0002	NCS125-4AF	26	CS1000-9942	1SBT171000R9942	56	NCS125-6AF	1SBT200206R0002	26
1SBT150100R0002	ES100F	17	1SBT200204R0102	NCS125-4VF	26	CS1000-9943	1SBT171000R9943	56	NCS125-6VF	1SBT200206R0102	26
1SBT150300R0001	ES300C	17	1SBT200206R0001	NCS125-6	26	CS1000BR	1SBT171000R0001	56	NCS125T-10AF	1SBT209210R0001	63
1SBT150300R0002	ES300F	17	1SBT200206R0002	NCS125-6AF	26	CS1000BRE	1SBT171000R0003	56	NCS125T-10VF	1SBT209210R0101	63
1SBT150300R0003	ES300S	17	1SBT200206R0102	NCS125-6VF	26	CS1000BRV	1SBT171000R0002	56	NCS125T-4AF	1SBT209204R0001	63
1SBT150500R0001	ES500C	17	1SBT200210R0001	NCS125-10	26	CS1000BRVE	1SBT171000R0004	56	NCS125T-4VF	1SBT209204R0101	63
1SBT150500R0002	ES500F	17	1SBT200210R0002	NCS125-10AF	26	CS2000-9944	1SBT172000R9944	56	NCS125T-6AF	1SBT209206R0001	63
1SBT150500R0003	ES500S	17	1SBT200210R0102	NCS125-10VF	26	CS2000-9945	1SBT172000R9945	56	NCS125T-6VF	1SBT209206R0101	63
1SBT150500R9672	ES500-9672	17	1SBT200306R0001	NCS305-6	27	CS2000BR	1SBT172000R0003	56	NCS165-10	1SBT200610R0001	26
1SBT150500R9673	ES500-9673	17	1SBT200306R0002	NCS305-6AF	27	CS2000BRV	1SBT172000R0004	56	NCS165-10AF	1SBT200610R0002	26
1SBT150500R9674	ES500-9674	17	1SBT200306R0102	NCS305-6VF	27	CS300-9877	1SBT170300R9877	56	NCS165-10VF	1SBT200610R0102	26
1SBT151000R0001	ES1000C	17	1SBT200310R0001	NCS305-10	27	CS300BR	1SBT170300R0001	56	NCS165-20	1SBT200620R0001	26
1SBT151000R0002	ES1000F	17	1SBT200310R0002	NCS305-10AF	27	CS300BRE	1SBT170300R0003	56	NCS165-20AF	1SBT200620R0002	26
1SBT151000R0003	ES1000S	17	1SBT200310R0102	NCS305-10VF	27	CS300BRV	1SBT170300R0002	56	NCS165-20VF	1SBT200620R0102	26
1SBT151000R9678	ES1000-9678	17	1SBT200320R0001	NCS305-20	27	CS300BRVE	1SBT170300R0004	56	NCS165-4	1SBT200604R0001	26
1SBT151000R9679	ES1000-9679	17	1SBT200320R0002	NCS305-20AF	27	CS500BR	1SBT170500R0001	56	NCS165-4AF	1SBT200604R0002	26
1SBT151000R9680	ES1000-9680	17	1SBT200320R0102	NCS305-20VF	27	CS500BRE	1SBT170500R0003	56	NCS165-4VF	1SBT200604R0102	26
1SBT152000R0001	ES2000F	17	1SBT200604R0001	NCS165-4	26	CS500BRV	1SBT170500R0002	56	NCS165-6	1SBT200606R0001	26
1SBT152000R0002	ES2000S	17	1SBT200604R0002	NCS165-4AF	26	CS500BRVE	1SBT170500R0004	56	NCS165-6AF	1SBT200606R0002	26
1SBT152000R0003	ES2000C	17	1SBT200604R0102	NCS165-4VF	26	CS503BR	1SBT170503R0001	56	NCS165-6VF	1SBT200606R0102	26
1SBT160050R0001	VS50B	78	1SBT200606R0001	NCS165-6	26	CS503BRE	1SBT170503R0003	56	NCS165T-10AF	1SBT209610R0001	63
1SBT160125R0001	VS125B	78	1SBT200606R0002	NCS165-6AF	26	EL100P2	1SBT130100R0001	16	NCS165T-10VF	1SBT209610R0101	63
1SBT160250R0001	VS250B	78	1SBT200606R0102	NCS165-6VF	26	EL100P2BB	1SBT130100R0002	16	NCS165T-20AF	1SBT209620R0001	63
1SBT160500R0001	VS500B	78	1SBT200610R0001	NCS165-10	26	EL25P1	1SBT132500R0001	16	NCS165T-20VF	1SBT209620R0101	63
1SBT160750R0001	VS750B	78	1SBT200610R0002	NCS165-10AF	26	EL25P1BB	1SBT132500R0002	16	NCS165T-4AF	1SBT209604R0001	63
1SBT161000R0001	VS1000B	78	1SBT200610R0102	NCS165-10VF	26	EL50P1	1SBT135100R0001	16	NCS165T-4VF	1SBT209604R0101	63
1SBT161500R0001	VS1500B	78	1SBT200620R0001	NCS165-20	26	EL50P1BB	1SBT135100R0003	16	NCS165T-6AF	1SBT209606R0001	63
1SBT162000R0001	VS2000B	78	1SBT200620R0002	NCS165-20AF	26	EL55P2	1SBT135100R0002	16	NCS165T-6VF	1SBT209606R0101	63
1SBT163000R0001	VS3000B	78	1SBT200620R0102	NCS165-20VF	26	EL55P2BB	1SBT135100R0004	16	NCS305-10	1SBT200310R0001	27
1SBT164000R0001	VS4000B	78	1SBT209204R0001	NCS125T-4AF	63	ES1000-9678	1SBT151000R9678	17	NCS305-10AF	1SBT200310R0002	27
1SBT164200R0001	VS4200B	78	1SBT209204R0101	NCS125T-4VF	63	ES1000-9679	1SBT151000R9679	17	NCS305-10VF	1SBT200310R0102	27
1SBT170000R2001	Side plate kit CST0	57	1SBT209206R0001	NCS125T-6AF	63	ES1000-9680	1SBT151000R9680	17	NCS305-20	1SBT200320R0001	27
1SBT170000R2002	Side plate kit CST1	57	1SBT209206R0101	NCS125T-6VF	63	ES1000C	1SBT151000R0001	17	NCS305-20AF	1SBT200320R0002	27
1SBT170000R2003	Bar kit CST0	57	1SBT209210R0001	NCS125T-10AF	63	ES1000F	1SBT151000R0002	17	NCS305-20VF	1SBT200320R0102	27
1SBT170000R2004	Bar kit CST1-6	57	1SBT209210R0101	NCS125T-10VF	63	ES1000S	1SBT151000R0003	17	NCS305-6	1SBT200306R0001	27
1SBT170000R2005	Bar kit CST1-10	57	1SBT209604R0001	NCS165T-4AF	63	ES100C	1SBT150100R0001	17	NCS305-6AF	1SBT200306R0002	27
1SBT170000R2007	Side plate kit CST2	57	1SBT209604R0101	NCS165T-4VF	63	ES100F	1SBT150100R0002	17	NCS305-6VF	1SBT200306R0102	27
1SBT170000R2008	Bar kit CST2	57	1SBT209606R0001	NCS165T-6AF	63	ES2000C	1SBT152000R0003	17	Side plate kit CST0	1SBT170000R2001	57
1SBT170000R2010	Bar kit CST1 special	57	1SBT209606R0101	NCS165T-6VF	63	ES2000F	1SBT152000R0001	17	Side plate kit CST1	1SBT170000R2002	57
1SBT170000R2012	Bar kit CST2 special	57	1SBT209610R0001	NCS165T-10AF	63	ES2000S	1SBT152000R0002	17	Side plate kit CST2	1SBT170000R2007	57
1SBT170300R0001	CS300BR	56	1SBT209610R0101	NCS165T-10VF	63	ES300C	1SBT150300R0001	17	VD1500-48	1SBT900000R0007	86
1SBT170300R0002	CS300BRV	56	1SBT209620R0001	NCS165T-20AF	63	ES300F	1SBT150300R0002	17	VD3000-25	1SBT903000R2501	86
1SBT170300R0003	CS300BRE	56	1SBT209620R0101	NCS165T-20VF	63	ES300S	1SBT150300R0003	17	VS1000B	1SBT161000R0001	78
1SBT170300R0004	CS300BRVE	56	1SBT210100R0001	HBO100	47	ES500-9672	1SBT150500R9672	17	VS125B	1SBT160125R0001	78
1SBT170300R9877	CS300-9877	56	1SBT210200R0001	HBO200	47	ES500-9673	1SBT150500R9673	17	VS1500B	1SBT161500R0001	78
1SBT170500R0001	CS500BR	56	1SBT210300R0001	HBO300	47	ES500-9674	1SBT150500R9674	17	VS2000B	1SBT162000R0001	78
1SBT170500R0002	CS500BRV	56	1SBT210400R0001	HBO400	47	ES500C	1SBT150500R0001	17	VS250B	1SBT160250R0001	78
1SBT170500R0003	CS500BRE	56	1SBT210500R0001	HBO500	47	ES500F	1SBT150500R0002	17	VS3000B	1SBT163000R0001	78
1SBT170500R0004	CS500BRVE	56	1SBT210600R0001	HBO600	47	ES500S	1SBT150500R0003	17	VS4000B	1SBT164000R0001	78
1SBT170503R0001	CS503BR	56	1SBT211000R0001	HBO1000	47	HBO100	1SBT210100R0001	47	VS4200B	1SBT164200R0001	78
1SBT170503R0003	CS503BRE	56	1SBT312500R0001	MP25P1	16	HBO200	1SBT210200R0001	47	VS500B	1SBT160500R0001	78
1SBT171000R0001	CS1000BR	56	1SBT900000R0007	VD1500-48	86	HBO300	1SBT210300R0001	47	VS50B	1SBT160050R0001	78
1SBT171000R0002	CS1000BRV	56	1SBT903000R2501	VD3000-25	86	HBO400	1SBT210400R0001	47	VS750B	1SBT160750R0001	78
1SBT171000R0003	CS1000BRE	56				HBO500	1SBT210500R0001	47			
1SBT171000R0004	CS1000BRVE	56				HBO600	1SBT210600R0001	47			
1SBT171000R9940	CS1000-9940	56				HBO1000	1SBT211000R0001	47			

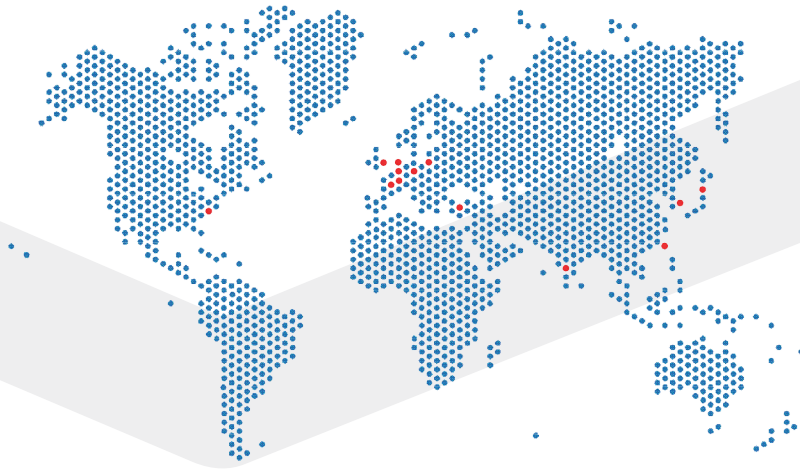

Germany

GVA Leistungselektronik GmbH
Boehinger Strasse 10-12
Mannheim D-68307
Tel: +49 (0) 621 : 76992-0
E-mail: info@gva-Leistungselektronik.de
www.gva-Leistungselektronik.de

UK

John G Peck Limited
Unit B1 Wymeswold Industrial Park
Wymeswold Lane
Burton on the Wolds
Loughborough, Leicestershire LE 12 5TY
United Kingdom
Tel: +44 (0) 1509 66 1010
E-mail: td@jgpl.com
www.jgpl.com

Turkey

CHM Elektronik
KemeraltiCaddegi Ada Han
87 Kat5 Karaköy
Istanbul 80030 Tophane
Tel: +90 (0) 212 293 95 91
E-mail: teoksy@dohm.com.tr
www.ohm.com.tr

Poland

PPH Comel Sp.z.o.o.Oddzial Gdynia
Uf. Crlowka 49 C
61-522 Gdynia
Tel: 058 6610167
E-mail: gdynia@comel.pl
www.comel.pl

Benelux

KWx b.V
Aston Martinaan 41
NL-3261 NB Oud-Beijerland
Tel: +31 (0) 166-633602
E-mail: info@kwx.nl
www.kwx.nl

Switzerland

Elektron AG
Riedhofstrasse 11
AU ZH CH-8804
Tel: +41 (0) 1 761 02 34
E-mail: elektronik@elektron.ch
www.elektron.ch

Denmark

Dovitech A/S
Midtagor 29
2605 Brandby
Tel: +45 70 25 26 50
E-mail: info@dovitech.dk
www.dovitech.dk

Inde

Pankaj Electronics
a-9, sector 67
Noida 201301 - UP
India
Tel: +91 0 78 4005 1401
E-mail: info@pankaj.biz

Taiwan

Industrade Co.Ltd
1DF, N°29-1
Zhong Zheng East Road
Tamsui district, new Taipei City
25170 Republic of China
Tel: +886 (2) 2609 1251
E-mail: info@industrade.com.tw
www.industrade.com.tw

Japan

Cronix Inc
Shinjuku Monolith 130, 2-3-1
Nishishijuku Shinjuku-ku Tokio
163-0913 Japan
Tel (Tokio): (81) 3 5322 - 7191
E-mail: sales@chronix.co.jp
www.chronix.co.jp

Korea

Milim
B214, Biz Consor SK Technopark 190-1
Sangdsowong-Dong, Jungwon-Gu
Seongnam-Si, Gyeonggi-Do 462-120 Korea
Tel: +62 31 776 2266-91
E-mail: milimsys@milimsys.com
www.milimsys.com

United States

5 S Components Inc
630 Fifth Avenue
East Mckeesport, PA 15035
Tel: +1 (412) 967 5858
E-mail: info@5scomponents.com
www.5scomponents.com

EXPERT IN GLOBAL SOLUTIONS



PETERCEM Sensors

Voltage and current sensors

3 rue Jean Perrin
F-69687 Chassieu cedex / France
Ph.: +33 (0)4 72 22 17 97
www.petercem.com



MAFELEC GROUP



FULL ELECTRONIC SYSTEM

www.fesys.fr



COMTRONIC

www.comtronic-schoenau.de



MAFELEC

www.mafelec.com



STOPCIRCUIT

www.stopcircuit.fr