

Voltage Sensor - VenuS 2000 V

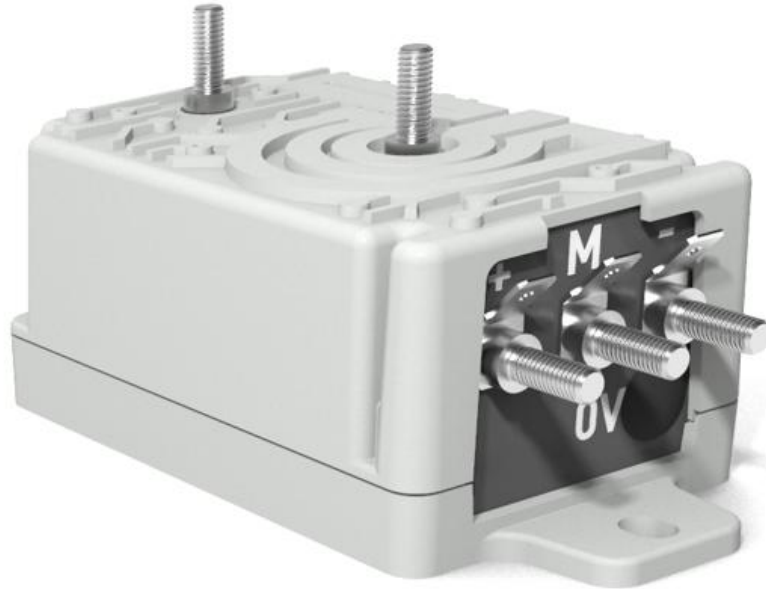

PVS2000I-1BCAA0 STANDARD

Measuring DC, AC., and pulsating voltages with a galvanic insulation between primary and secondary circuits.



KEY FEATURES

- Bipolar and insulated measurement up to 2000 Vrms AC/DC
- Bipolar current output 50 mA rms
- Primary Input and secondary output connections designed for M5 studs
- Secondary output connections 3x M5 studs

APPLICATIONS



Overall dimensions

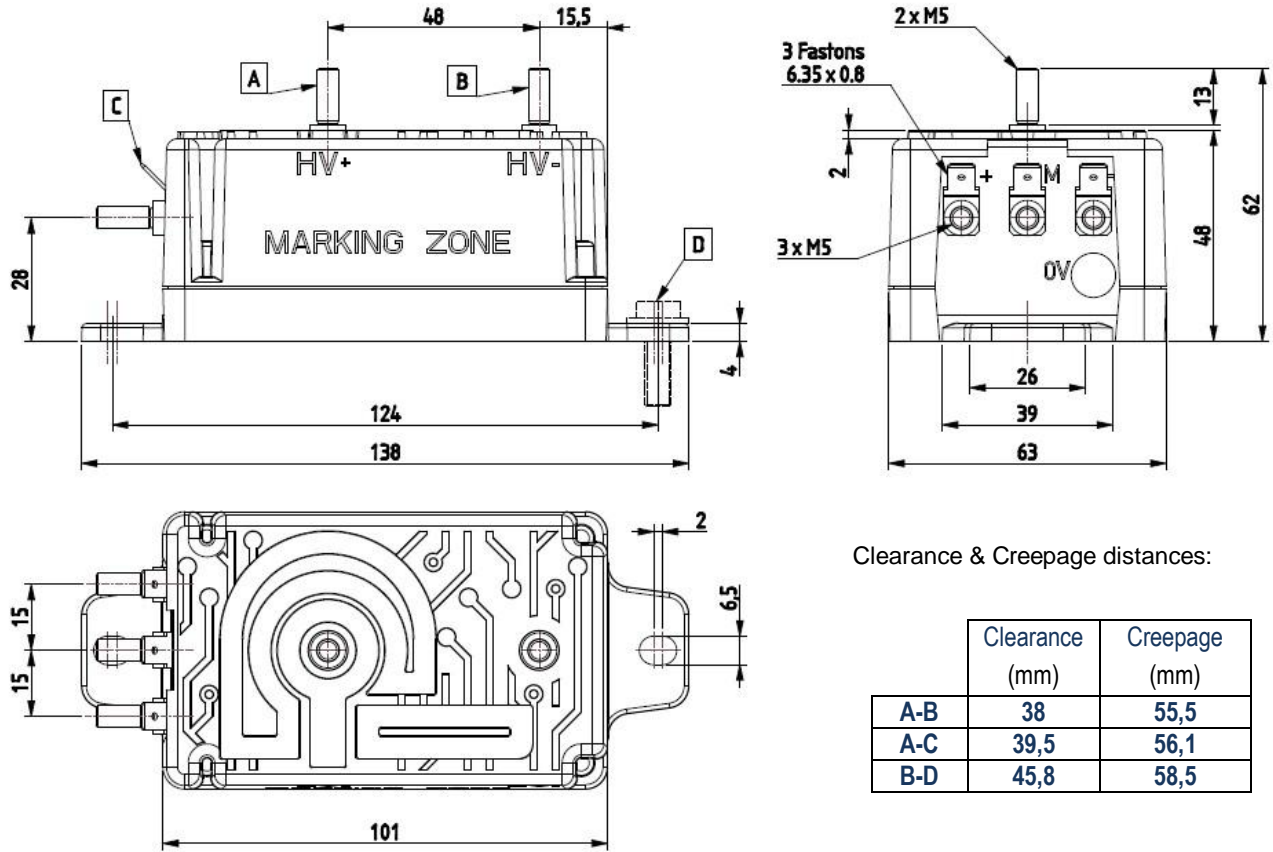

Mechanical characteristics

- General tolerance ± 1 mm
- Outline 138mm(Z)X63mm(X)x62mm(Y)
- Sensor fixing 2x M6 screws
- Primary connection 2x M5 Threaded studs
- Secondary connection 3x M5 threaded studs
- Recommended M5 tightening torque 2,2 N.m max
- Mass < 280g
- Assembly requirements Operational in any position



Synoptic (current output)

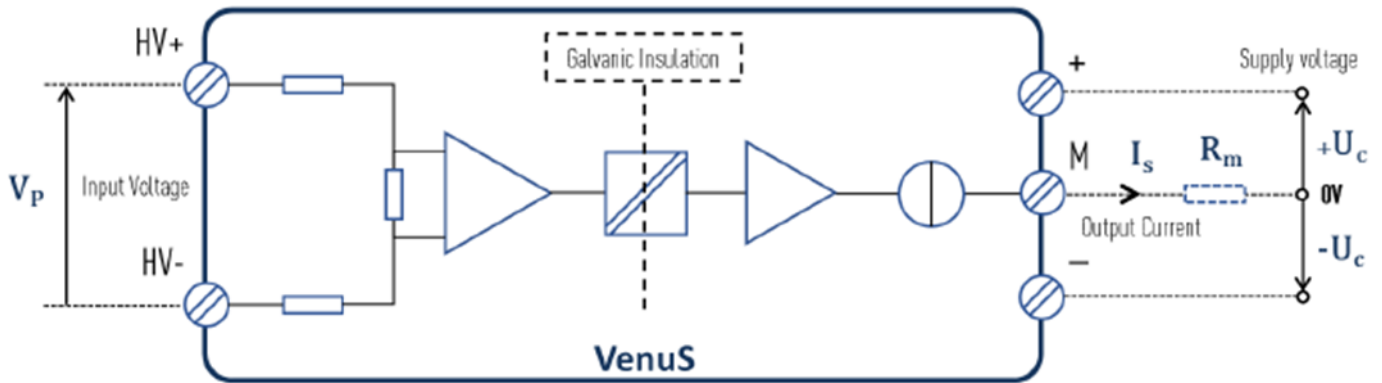

Voltage range

Parameters	Symbol	Unit	Value
Operating primary voltage	V_{PN}	V_{rms}	2000
Maximum primary voltage (measuring range)	V_{Pmax}	V_{peak}	± 3000
Operating secondary supply voltage range	U_c	V_{DC}	± 24
Maximum secondary supply voltage range (Peak)	U_{Cmax}	V_{DC}	± 34
Minimum secondary supply voltage range	U_{Cmin}	V_{DC}	± 15

Operating at mentioned maximums voltage for an extended period may degrade reliability.

Using the device beyond these voltage ranges may cause permanent damage that could not be considered as under Petercem's responsibility.

Temperature range

Parameters	Symbol	Unit	Min	Max
Operating temperature range	T_o	$^{\circ}C$	-40	+85
Storage temperature range	T_s	$^{\circ}C$	-50	+90
Room temperature	T_A	$^{\circ}C$	20	25

All mentioned electrical performances in this data sheet apply only in the operating temperature range unless otherwise specified.

Operating at mentioned extreme temperatures for an extended period may degrade reliability.

Using the device beyond these temperature ranges may cause permanent damage that could not be considered as under Petercem's responsibility.



Insulation properties

Parameters	Symbol	Unit	Value	Comments
Dielectric test AC, 50 Hz, 1min	U_d	kV _{rms}	8,5	100% tested
Impulse withstand voltage 1.2/50 μ s	\hat{U}_w	kV	16	
Partial discharges ; Extinction voltage(@ 10pC, 50Hz)	U_e	kV _{rms}	2,7	
Insulation resistance	R_{INS}	M Ω	200	@500Vdc
Primary resistance	P_r	M Ω	11,3	
Case material (according to UL94)	-	-	V0	
Comparative tracking index	CTI	-	600	
Pollution degree	PD	-	PD2	
Overvoltage	OV	-	OV3	
Clearance distance	Cl.	mm	See dimension values on page 2	
Creepage distance	Cr.	mm		
Sealing	IP		IP4X	
Maximum DC common mode voltage	$U_{HT+} + U_{HT-}$ $ U_{HT+} - U_{HT-} $	kV	≤ 4.2 $\leq V_{PM}$	



Electrical performances

Parameters	Symbol	Unit	Min.	Typ.	Max.	Comments
Secondary nominal current RMS	I_{sn}	mA		±50		
Maximum secondary current AC @ V _{PN}	I_s	mApp	-75		75	
Overall accuracy	X_G	% of V _{PN}	-1		+1	-40.....+85°C
Accuracy @ T _A	X_G	% of V _{PN}	-0.5		+0.5	25°C
Frequency bandwidth @ 14 kHz	BW	dB		-3		See Figure 1
Measuring resistance	R_M	Ω	0	133	200	
Current consumption @ U _c = ±24V at V _P = 0 V	I_c	mA		70		
Offset current	I_o	μA	55		55	
Linearity drift ; ± 3000 Vpp range	ε_L	% of V _{PN}	-0.5		0.5	
Total primary power loss @ V _P N	P_P	W		0.35W		
Start-up time	t_{start}	ms			250	
Dv/dt correctly followed	Dv/dt	V/μS			24	
Response time	T_{D10}	μS	40			
Sensitivity error	ε_s	%	-0,2		+0,2	
Sensitivity	S	μA/V		25		
Rise time of U _c (10-90%)	t_{rise}	ms			100	

Particularities

Parameters	Symbol	Unit	Min.	Typ.	Max.	Comments
Burn in test according to cycle						FPTC404304



Standards

Standards	Revision
EN 50155: OT6, ST0, H2, PC2	2021
EN 50124-1	2017
EN 50121-3-2	2019
EN 50 128	2011
EN 50178	1997
EN 45545 HL2	2013
IEC 61010	2016
UL 508	2003 (Pending)
UL 347	2018 (Pending)
UL 94-V0	2022

UL347 - Certification Ratings and Underlying Assumptions

Conditions for Acceptance:

1. These components must be installed within an appropriate enclosure for their intended end-use application.
2. The device's Basic Insulation Level is rated at 16kV, which has been verified through Impulse Withstand Testing. If a higher BIL rating is requested, we need to plan more tests on our VenuS and the cost of the tests will be borne by the applicant.



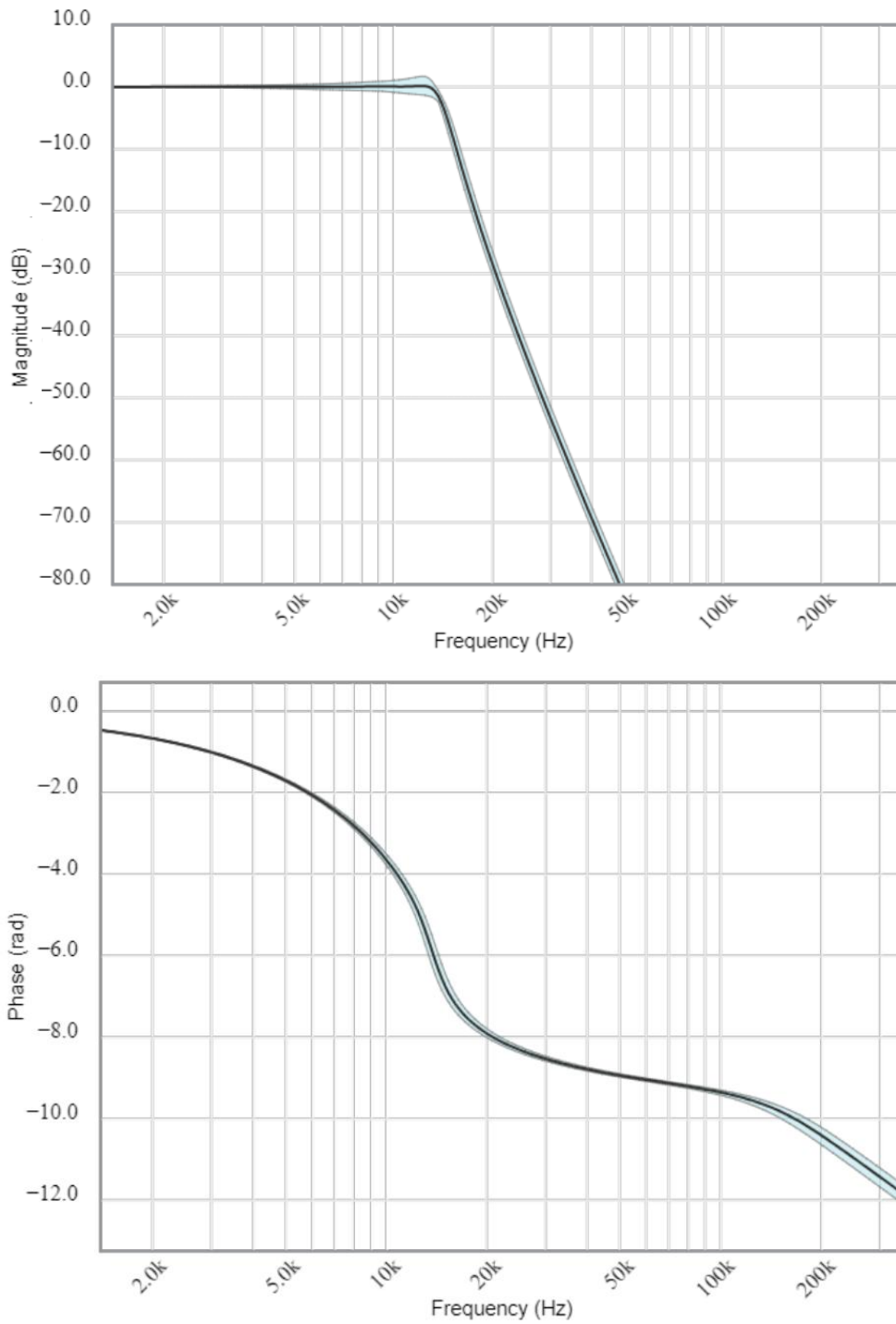

Figure 1: Bandwidth evolution



Safety warnings

This sensor must be used in electrical circuits according to EN61010-1.



This sensor must be used in electric/electronic equipment with respect to applicable standards and safety requirements in accordance with the system instructions and internal customer rules.



Caution: risk of electrical shock. When operating the sensor, certain parts can carry hazardous voltages (primary bar, power supply...). Ignoring this warning can lead to injury and/or cause serious damage.



✉ Petercem-SENSORS@petercem.fr

☎ +33 (0)4 72 90 00 65

www.petercem-sensors.com



MAFELEC TEAM

