

## Datablad

### Ultrasnabb halvledarsäkring

#### Square Body – 1250V och 1500V

*Bultmonterade aR-säkringar enligt IEC 60269-4 och DIN 43653*

#### Innehåll

Allmän information – halvledarskydd	sida 2
Indikatorer och mikrobrytare	sida 3
Square Body S 1250V – produktdata	sida 4
Square Body G 1250V – produktdata	sida 5
Square Body S 1500V – produktdata	sida 6
Square Body G 1500V – produktdata	sida 7
Tillbehör – mikrobrytare och adaptrar	sida 8
Karaktäristikkurvor 1250V (aR)	sida 9
Karaktäristikkurvor 1500V (aR)	sida 10

*Detta datablad är ett utdrag ur tillverkarens katalog och avser de varianter som Inkom marknadsför inom kategorin Square Body 1250V/1500V. För andra spänningsklasser, tid-strömkurvor under  $L/R = 2$  ms eller specifik DC-data – kontakta Inkom.*

# Fuses for semiconductor devices protection

## General information

Fuses are the oldest protective devices in the electrical industry. Because of the advantageous features, fuses have been and are used in an extensive fields of applications – one of them is protection of semiconductor devices (diodes, thyristors, power transistors, GTO) in current and frequency converters. Semiconductor devices are being produced with high maximum continuous currents and peak inverse voltages. Unfortunately, that devices still have poor overload capacities and continue to need sensitive and fast-acting protection.

ETI fuses for semiconductor protection series ULTRA-QUICK are optimal solution for the protection of power semiconductors.

General informations about fuse marking

Fuse marking consists of two letters, where the first letter describes the breaking ranges

### a - partial range

Operates by all currents between the lowest current indicated on its operating time current characteristic and its rated breaking capacity.

### g - full range

Operates by all currents which cause the melting of the fuse element up to its rated breaking capacity

The second letter describes the applications (characteristics or utilization category).

- L** – mainly for conductor protection
- B** – mining equipment
- M** – motor circuit and switching devices protection
- R** – semiconductor protection
- Tr** – transformers protection

The combination of “breaking ranges” and “applications” indicate many combinations describes in standards and technical report IEC TR 61818 “Application-guide for low voltage fuses”

- |                |                         |  |
|----------------|-------------------------|--|
| <b>gL:</b>     | Full range              | - general application, mainly for conductor protection |
| <b>aM:</b>     | Partial range (back-up) | - short-circuit protection of motor circuit            |
| <b>gR, gS:</b> | Full range              | - semiconductor protection                             |
| <b>aR:</b>     | Partial range (back-up) | - semiconductor protection                             |
| <b>gB:</b>     | Full range              | - mining equipment protection                          |
| <b>gTr:</b>    | Full range              | - transformer protection                               |

ETI fuses for semiconductor protection series “ULTRA-QUICK” comply with the IEC 60269 and VDE 0636 series standard. A list of the standards for characteristics and dimensions is included below:

- IEC 60269-4: Supplementary requirements for fuselinks for the protection of semiconductor devices
- IEC 60269-4-1: Examples of standardized fuses
- IEC 60269-3-1: Supplementary requirements for fuses for use by unskilled persons (fuses mainly for household and similar applications)
- IEC 60269-2-1: Supplementary requirements for fuses for use by authorized persons (fuses mainly for industrial application) for the protection of semiconductor devices
- DIN 43 620, DIN 43 653
- VDE 0636-201 Niederspannungssicherungen (NH-System)
- DIN EN 60269-4, VDE 0636 Teil 40 Niederspannungssicherungen Teil 4: Zusätzliche Anforderung an
- BS 88 Part 4

Fuse-links as protective equipment for semiconductors should ensure that the following conditions are met:

- Interruption should be effected quickly enough to prevent damage to other devices
- Interruption should take place before damage to semiconductor devices – quick action
- High rated breaking capacity
- High d.c. switching capacity
- High current limitation
- Operation of the protective equipment should not cause unacceptably high over-voltages to be impressed on any of the semiconductor devices – low arc voltage

## Selecting the fuses for semiconductor protection (FSP)

What the user should know about FSP to be able to select the best FSP for his special purpose?

In practice, there exist no common regulations covering FSPs, except IEC60146-6 „Applications guide for the protection of semiconductor converters against overcurrent by fuses“. The object of this report is to advise on the specific fuse features and on the specific converter features which are to be observed to ensure correct application of FSP in converters, and to give specific recommendations for trouble-free operation of converters protected by fuses.

Before the fuse selection the user must be fully aware of the conditions under which the FSP is to function. This applies to normal service conditions as well as to conditions during fault. Here is few basic suggestions for FSP selection:

**A:** The load current through the semiconductor ( $I_{sem}$ ) should be lower or equal as the rated current of the selected fuse-link ( $I_{nv}$ ). For continuous duty the FSP can withstand this current indefinitely. In case of pulsed current, the user should consult ETI.

$$I_{sem} \leq I_{nv}$$

**B:** The operating voltage on the semiconductor ( $U_{sem}$ ) should be lower or equal as the rated voltage of the fuse-link ( $U_{nv}$ ). Consult ETI with respect to a.c. and d.c. applied voltage, time constant and power factor.

$$U_{sem} \leq U_{nv}$$

**C:** The operating (pre-arcing + arcing)  $I^2t$  values of the selected fuse-link ( $I^2t_{opv}$ ) should be lower than  $I^2t$  of the semiconductor ( $I^2t_{sem}$ ). Consult ETI with respect to parallel operation, discrimination and loss of coordination at higher fault levels

$$I^2t_{opv} < I^2t_{sem}$$

**D:** For other current rating, which are not included in this catalogue, please consult ETI R&D department.

## Operation indicators of ULTRA-QUICK fuse links

The operation-sensing device is a fine wire which is connected in parallel with the fuse melting element. This wire is used to hold in a flag (made of thin metal band) usually placed on the upper cover. When the wire breaks because of fuse operate, the flag is pushed out and in this way an indication of operation is given.

The indicator on pic.1 is a visual indication of fuse operating. When only indication is not enough, we offering possibility to add a microswitch NV55 on the upper cover for remote signalling of fuse operating (Pic.2).

Another type of signalling of fuse operating is indicator, called "middle". It is located in the center of the ceramic body in front of the fuse link. After fuse operation, the particular plastic striker is pushed out from the ceramic body (Pic.3).



Pic. 1

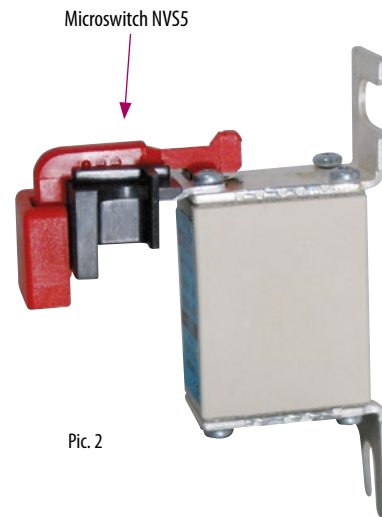

Pic. 2

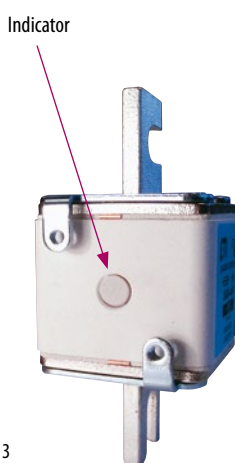

Pic. 3

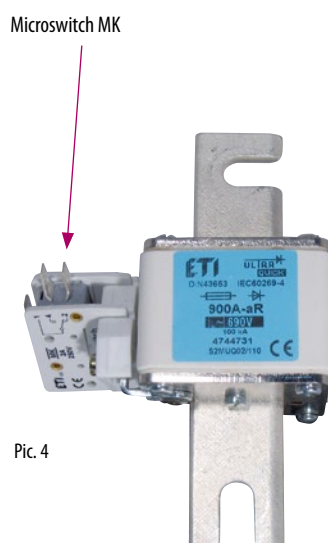

Pic. 4

For remote signaling we offering microswitch MK (Pic.4 and Pic.5) mounted on additional adapters AMK (Pic.6 and Pic.7)

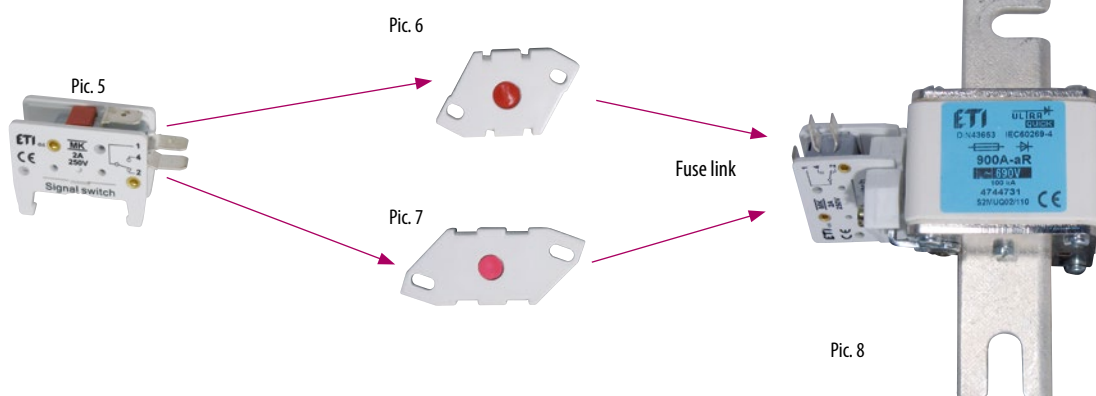

The purpose of adapters AMK1 and AMK2 are microswitch type MK setting up on the fuse link body of sizes for 690V and 1000V.

Technical data on page 97

aR

TYPES  
S

RATED VOLTAGE  
~1250V

Technical data:

Standards:  
IEC 60269-4

Breaking capacity:  
~100kA  
Rated voltage:  
~1250V

Application:

Protection of semiconductors inside middle voltage inverters.

S3MUQ01/110/1000A/1250V



Size	In (A)	Type with centre trip indicator for microswitch MK	Code No.	Pre-arcing I <sup>2</sup> t-value (A <sup>2</sup> s)	Operating I <sup>2</sup> t-value at 1000V (A <sup>2</sup> s)	Operating I <sup>2</sup> t-value at 1250V (A <sup>2</sup> s)	Power dissipation (W)	Char.	Pack. (pcs)	Weight (g)
2	250	S2MUQ01/110/250A/1250V	004735130	7.500	40.500	52.650	54	aR	1	800
	350	S2MUQ01/110/350A/1250V	004735131	18.000	99.500	133.000	66	aR		
	400	S2MUQ01/110/400A/1250V	004735132	25.000	150.000	190.000	85	aR		
	450	S2MUQ01/110/450A/1250V	004735133	37.000	215.000	277.000	100	aR		
	630	S2MUQ01/110/630A/1250V	004735134	123.000	585.000	740.000	125	aR		
3	710	S2MUQ01/110/710A/1250V	004735135	172.000	820.000	1.060.000	130	aR	1	1000
	315	S3MUQ01/110/315A/1250V	004735129	11.500	60.000	78.000	53	aR		
	350	S3MUQ01/110/350A/1250V	004735136	15.500	83.500	111.000	66	aR		
	450	S3MUQ01/110/450A/1250V	004735137	33.500	190.000	246.000	98	aR		
	630	S3MUQ01/110/630A/1250V	004735138	86.000	500.000	660.000	121	aR		
1000	S3MUQ01/110/1000A/1250V	004735139	480.000	2.100.000	2.730.000	137	aR			

Dimensions:

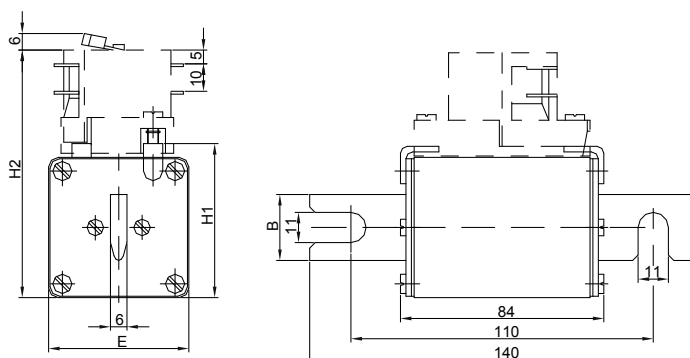

Size	B	E	H1	H2
2	30	60	65	99
3	37	75	80	114

ULTRA QUICK

# NV/NH

Technical data on page 97

aR

TYPES  
G

RATED VOLTAGE  
~1250V

Technical data:			Application:
Standards: IEC 60269-4	Breaking capacity: ~100kA Rated voltage: ~1250V		Protection of semiconductors inside middle voltage inverters.

Size	In (A)	Type with centre trip indicator for microswitch MK	Code No.	Pre-arcing I <sup>2</sup> t-value (A <sup>2</sup> s)	Operating I <sup>2</sup> t-value at 1000V (A <sup>2</sup> s)	Operating I <sup>2</sup> t-value at 1250V (A <sup>2</sup> s)	Power dissipation (W)	Char.	Packaging (pcs)	Weight (g)
3	315	G3MUQ01/315A/1250V	004735140	11.500	60.000	78.000	53	aR	1	1000
	500	G3MUQ01/500A/1250V	004735141	49.000	240.000	312.000	93	aR		
	575	G3MUQ01/575A/1250V	004735142	58.000	330.000	433.000	102	aR		
	630	G3MUQ01/630A/1250V	004735143	86.000	500.000	660.000	113	aR		
	710	G3MUQ01/710A/1250V	004735144	128.000	710.000	930.000	125	aR		
	800	G3MUQ01/800A/1250V	004735145	225.000	1.000.000	1.300.000	136	aR		
	900	G3MUQ01/900A/1250V	004735146	325.000	1.450.000	1.950.000	148	aR		
	1000	G3MUQ01/1000A/1250V	004735147	480.000	2.100.000	2.730.000	162	aR		

### Dimensions:

G3MUQ01/500A/1250V

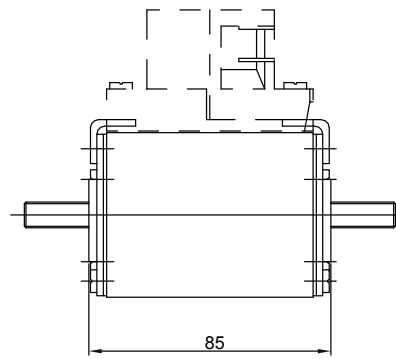
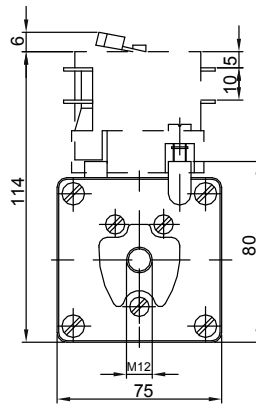

Technical data on page 98

aR

TYPES  
S

RATED VOLTAGE  
~1500V

Technical data:

Standards:  
IEC 60269-4

Breaking capacity:  
~50kA  
Rated voltage:  
~1500V

Application:

Protection of semiconductors inside middle voltage inverters.

S3MUQ01/140/550A/1500V

Size	In (A)	Type with centre trip indicator for microswitch MK	Code No.	Operating I <sup>2</sup> t-value at 1500V (A <sup>2</sup> s)	Power dissipation (W)	Char.	Pack. (pcs)	Weight (g)
3	250	S3MUQ01/140/250A/1500V	004735150	110.000	95	aR	1	1500
	315	S3MUQ01/140/315A/1500V	004735151	170.000	110	aR		
	400	S3MUQ01/140/400A/1500V	004735152	330.000	128	aR		
	450	S3MUQ01/140/450A/1500V	004735153	390.000	135	aR		
	550	S3MUQ01/140/550A/1500V	004735154	700.000	153	aR		



Dimensions:

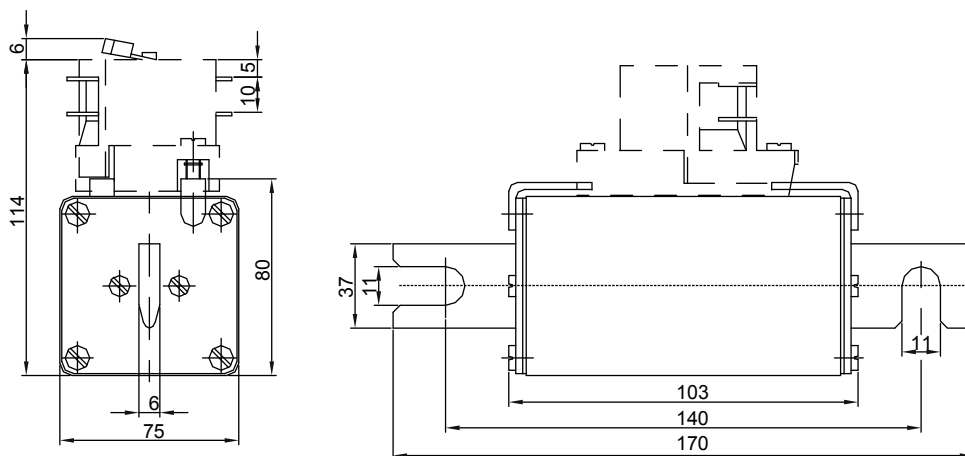

ULTRA QUICK

# NV/NH

Technical data on page 98

aR

TYPES  
G

RATED VOLTAGE  
~1500V

Technical data:			Application:
Standards: IEC 60269-4	Breaking capacity: ~50kA Rated voltage: ~1500V		Protection of semiconductors inside middle voltage inverters.

Size	In (A)	Type with centre trip indicator for microswitch MK	Code No.	Operating I <sup>2</sup> t-value at 1500V (A <sup>2</sup> s)	Power dissipation (W)	Char.	Packaging (pcs)	Weight (g)
2	200	G2MUQ01/200A/1500V	004735155	45.000	40	aR	1	1500
	250	G2MUQ01/250A/1500V	004735156	125.000	60	aR	1	1500

### Dimensions:

G2MUQ01/250A/1500V

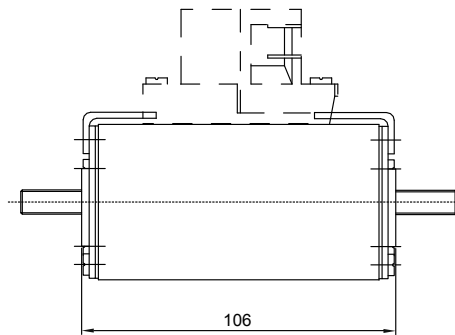
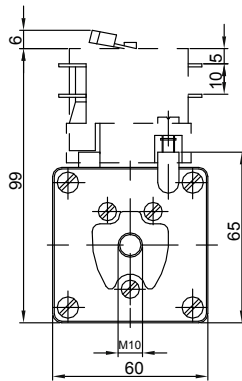

CHARACTERISTICS

RATED VOLTAGE  
= 1200V

Time/current characteristics of fuse links CH gR size 10 x 85

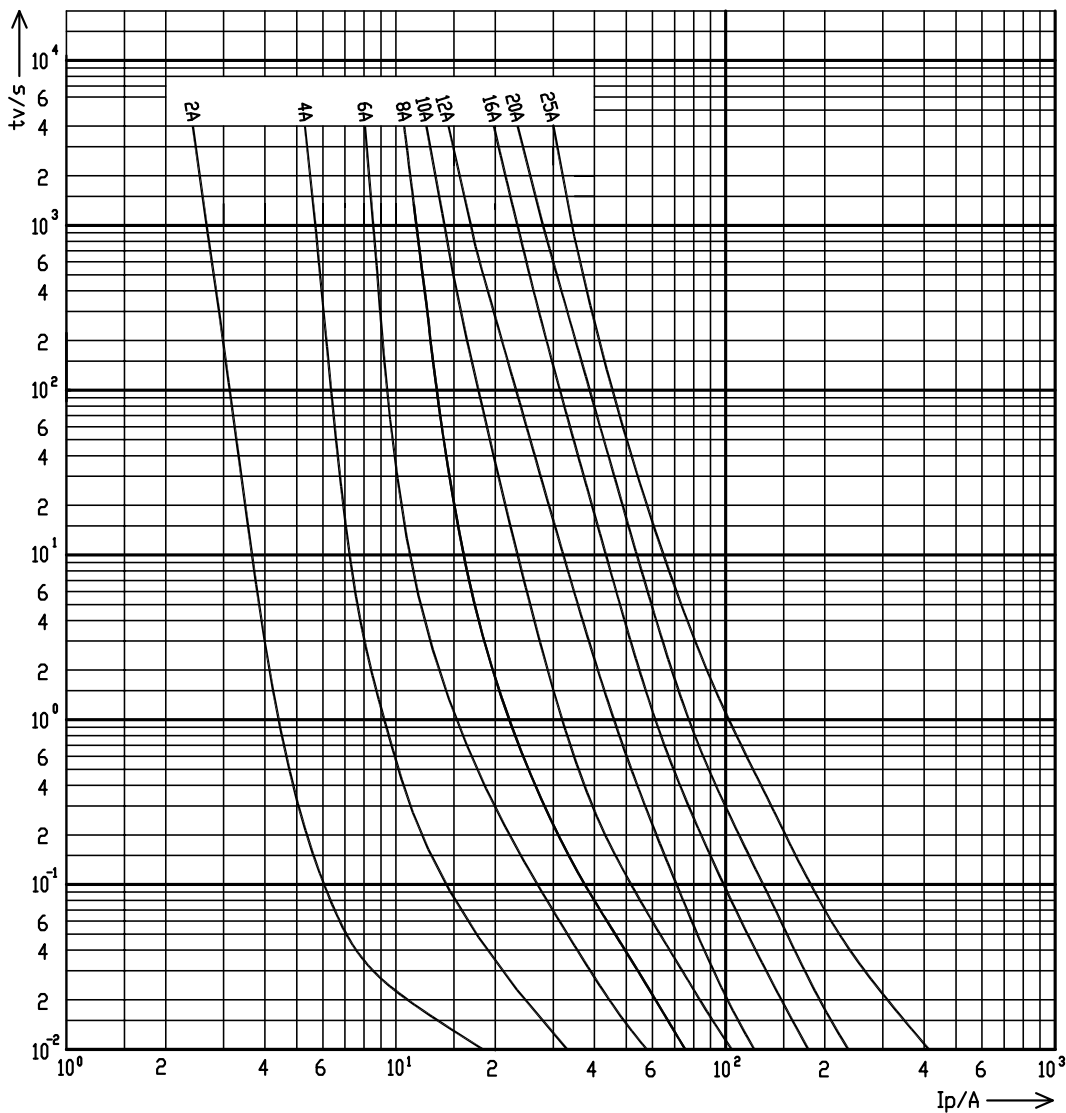

Tamb (°C)	A1
-20	1,179
-10	1,140
0	1,100
10	1,057
20	1,014
30	0,968
40	0,919
50	0,869
60	0,815
70	0,757
80	0,694

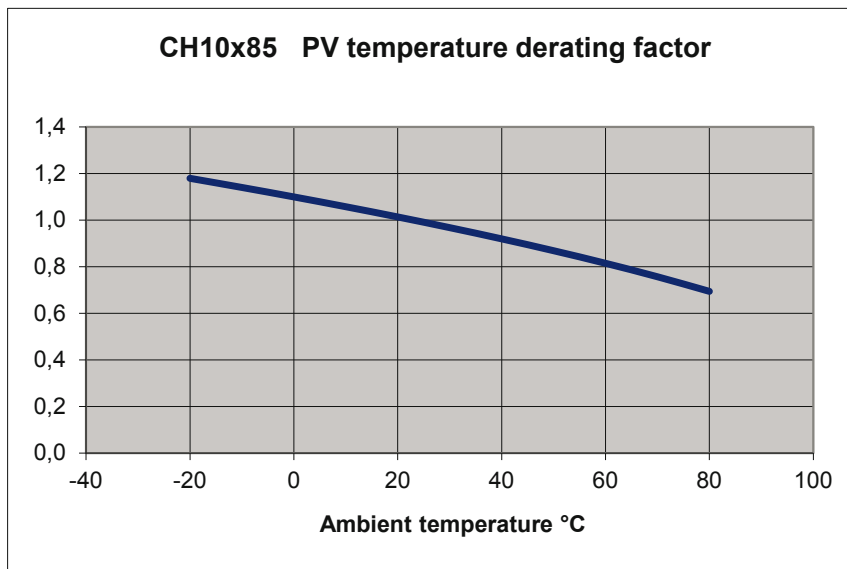

CHARACTERISTICS

NV/NH

aR

RATED VOLTAGE  
~1250V

Time-current characteristics

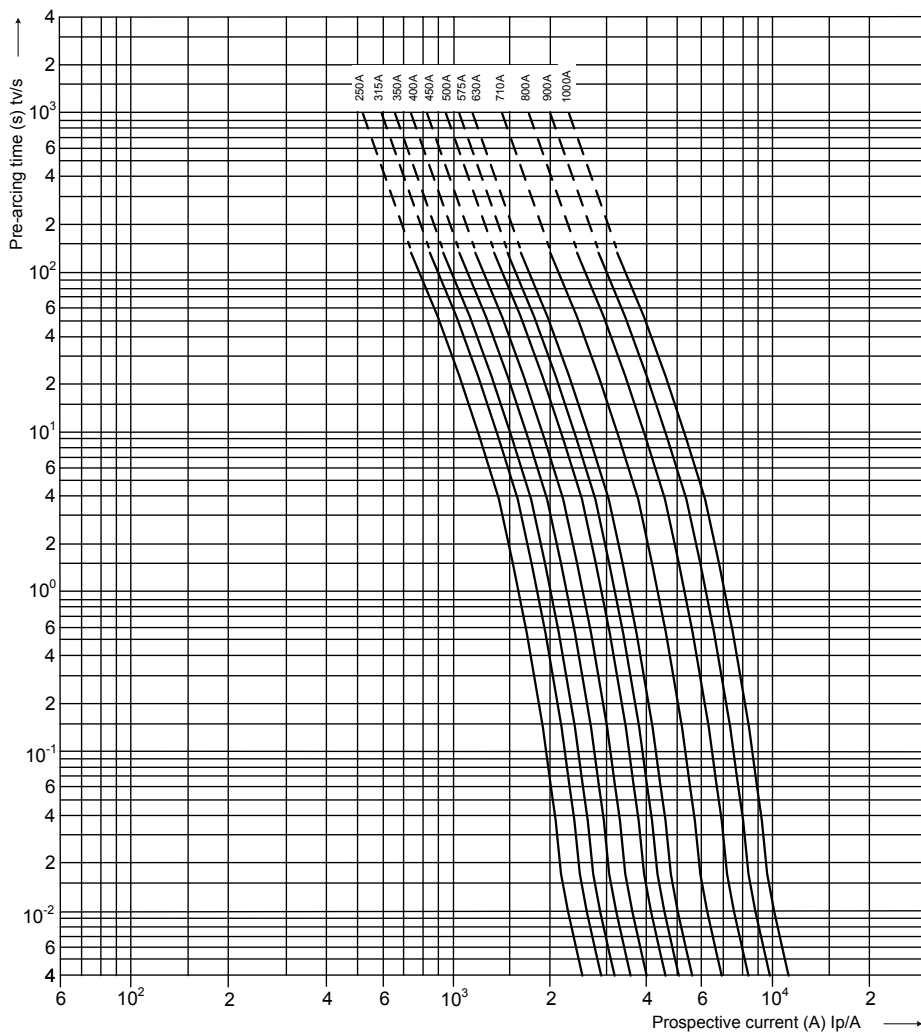

Conversion factor for total Joule integral

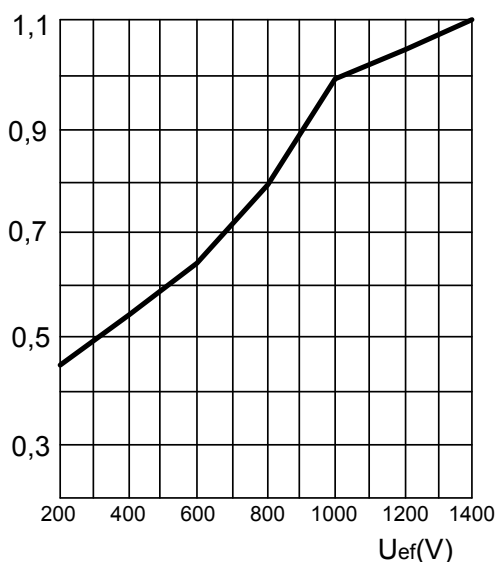

Maximum arc voltage accuring

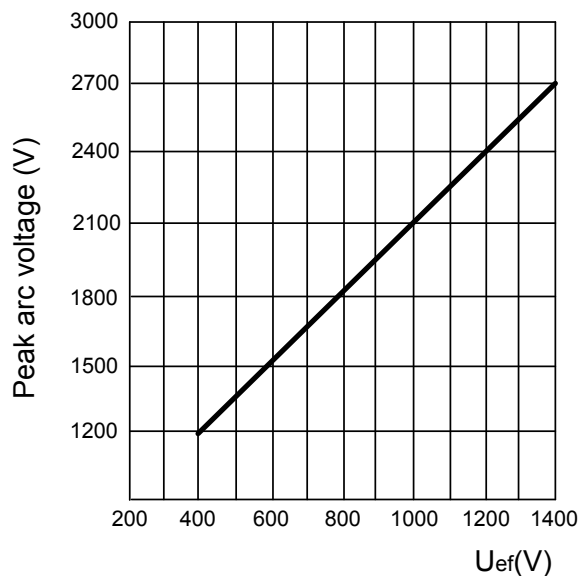

ULTRA QUICK

# NV/NH

## CHARACTERISTICS

aR

RATED VOLTAGE  
~1500V

### Time-current characteristics

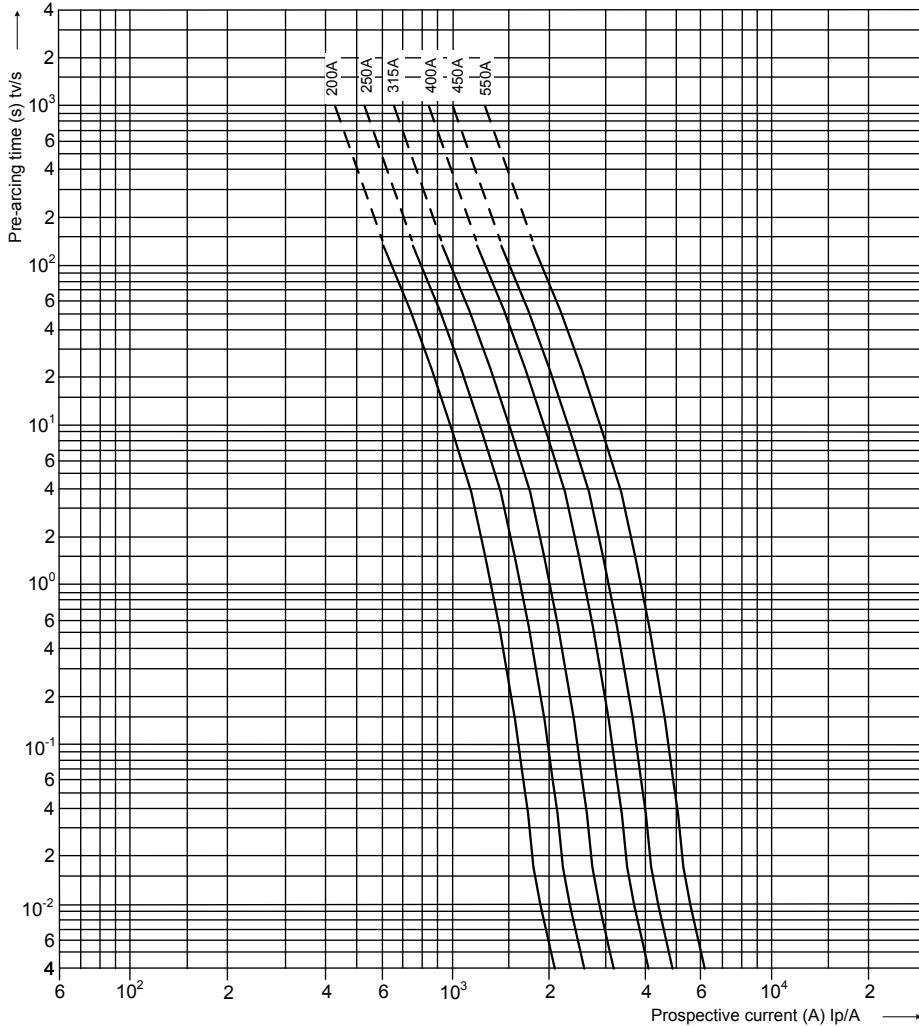

ULTRA QUICK

### Conversion factor for total Joule integral

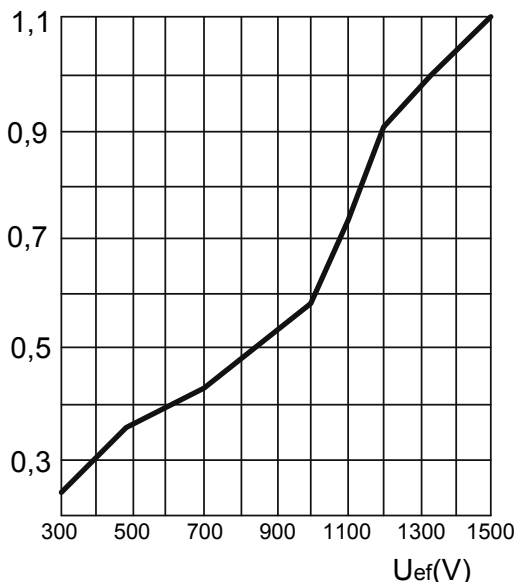

### Maximum arc voltage accuring

